

Q.5 The solution of $(D^2 + 2D + 2)y = 0, y(0) = 0, y'(0) = 1$ is

- (A) $e^x \sin x$ (B) $e^{-x} \cos x$
 (C) $e^{-x} \sin x$ (D) $e^x \cos x$

Ans: C

Q.6 The solution of $y' + y \tan x = \cos x, y(0) = 0$ is

- (A) $\sin x$ (B) $\cos x$
 (C) $x \sin x$ (D) $x \cos x$

Ans: D

Q.7 . Let $v_1 = (1,1,0,1), v_2 = (1,1,1,1), v_3 = (4,4,1,1)$ and $v_4 = (1,0,0,1)$ be elements of \mathbb{R}^4 . The set of vectors $\{v_1, v_2, v_3, v_4\}$ is

- (A) linearly independent (B) linearly dependent
 (C) null (D) none of these

Ans: A

Q.8 The eigen values of the matrix $\begin{pmatrix} 1 & 1 & -2 \\ -1 & 2 & 1 \\ 0 & 1 & -1 \end{pmatrix}$ are

- (A) $-1, 2$ and 1 (B) $0, 1$ and 2
 (C) $-1, -2$ and 4 (D) $1, 1$ and -1

Ans: A

Q.9 Let P_0, P_1, P_2 be the Legendre polynomials of order 0, 1, and 2, respectively. Which of the following statement is correct?

- (A) $P_2(x) = 3xP_1(x) + \frac{1}{2}P_0(x)$ (B) $P_2(x) = \frac{3}{2}xP_1(x) - \frac{1}{2}P_0(x)$
 (C) $P_2(x) = \frac{3}{2}xP_1(x) + P_0(x)$ (D) $P_2(x) = \frac{1}{2}xP_1(x) + \frac{3}{2}P_0(x)$

Ans: B

Ans: C

- Q.16** The system of equations is said to be inconsistent, if it has
 (A) unique solution (B) infinitely many solutions
 (C) no solution (D) identity solution

Ans: C

- Q.17** The differential equation $M(x, y)dx + N(x, y)dy = 0$ is an exact differential equation if
 (A) $\frac{\partial M}{\partial y} \neq \frac{\partial N}{\partial x}$ (B) $\frac{\partial M}{\partial y} = \frac{\partial N}{\partial x}$
 (C) $\frac{\partial M}{\partial x} = \frac{\partial N}{\partial y}$ (D) $\frac{\partial M}{\partial y} - \frac{\partial N}{\partial x} = 1$

Ans: B

- Q.18** The integrating factor of the differential equation $x(1 + y^2)dy + y(1 + x^2)dx = 0$ is
 (A) $\frac{1}{x}$ (B) $\frac{1}{y}$
 (C) xy (D) $\frac{1}{xy}$

Ans: D

- Q.19** The functions x, x^2, x^3 defined on an interval I, are always
 (A) linearly dependent (B) homogeneous
 (C) identically zero or one (D) linearly independent

Ans: D

- Q.20** The value of $J_1''(x)$, the second derivative of Bessel function in terms of $J_2(x)$ and $J_1(x)$ is
 (A) $xJ_2(x) + J_1(x)$ (B) $\frac{1}{x}J_2(x) + J_1(x)$
 (C) $\frac{1}{x}J_2(x) - J_1(x)$ (D) $J_2(x) - \frac{1}{x}J_1(x)$

Ans: C

- Q.21** The value of limit $\lim_{(x,y) \rightarrow (0,0)} \frac{x \cdot \sin(x^2 + y^2)}{x^2 + y^2}$ is
 (A) 0 (B) 1
 (C) -1 (D) does not exist

Ans: A

Q.22 If $f(x, y) = e^{xy^2}$, the total differential of the function at the point (1, 2) is

- (A) $e(dx + dy)$ (B) $e^2(dx + dy)$
 (C) $e^4(4dx + dy)$ (D) $4e^4(dx + dy)$

Ans: D

Q.23 Let $u(x, y) = x^2 \tan^{-1}\left(\frac{x}{y}\right) - y^2 \tan^{-1}\left(\frac{x}{y}\right)$, $x > 0, y > 0$ then $x^2 \frac{\partial^2 u}{\partial x^2} + 2xy \frac{\partial^2 u}{\partial x \partial y} + y^2 \frac{\partial^2 u}{\partial y^2}$

equals

- (A) 0 (B) 2u
 (C) u (D) 3u

Ans: B

Q.24 The value of the integral $\iiint_E xyz dx dy dz$, over the domain E bounded by planes

$x = 0, y = 0, z = 0, x + y + z = 1$ is

- (A) $\frac{1}{20}$ (B) $\frac{1}{40}$
 (C) $\frac{1}{720}$ (D) $\frac{1}{800}$

Ans: C

Q.25 The value of α so that $e^{\alpha y^2}$ is an integrating factor of the differential equation

$$\left(e^{\frac{-y^2}{2} - xy} \right) dy - dx = 0$$

- (A) -1 (B) 1
 (C) $\frac{1}{2}$ (D) $-\frac{1}{2}$

Ans: C

Q.26 The complementary function for the solution of the differential equation

$2x^2 y'' + 3xy' - 3y = x^3$ is obtained as

- (A) $Ax + Bx^{-3/2}$ (B) $Ax + Bx^{3/2}$
 (C) $Ax^2 + Bx$ (D) $Ax^{-3/2} + Bx^{3/2}$

Ans: A

- Q.27** Let $V_1 = (1, -1, 0)$, $V_2 = (0, 1, -1)$, $V_3 = (0, 0, 1)$ be elements of \mathbb{R}^3 . The set of vectors $\{V_1, V_2, V_3\}$ is
- (A) linearly independent (B) linearly dependent
 (C) null (D) none of these

Ans: A

- Q.28** The value of μ for which the rank of the matrix $A = \begin{bmatrix} \mu & -1 & 0 & 0 \\ 0 & \mu & -1 & 0 \\ 0 & 0 & \mu & -1 \\ -6 & 11 & -6 & 1 \end{bmatrix}$ is equal to 3 is
- (A) 0 (B) 1
 (C) 4 (D) -1

Ans: B

- Q.29** Using the recurrence relation, for Legendre's polynomial $(n + 1) P_{n+1}(x) = (2n + 1)x P_n(x) - nP_{n-1}(x)$, the value of $P_2(1.5)$ equals to
- (A) 1.5 (B) 2.8
 (C) 2.875 (D) 2.5

Ans: C

- Q.30** The value of Bessel function $J_2(x)$ in terms of $J_1(x)$ and $J_0(x)$ is
- (A) $2J_1(x) - x J_0(x)$ (B) $\frac{4}{x} J_1(x) - J_0(x)$
 (C) $2J_1(x) - \frac{2}{x} J_0(x)$ (D) $\frac{2}{x} J_1(x) - J_0(x)$

Ans: D

- Q.31** The value of the integral $\int_C \frac{z^2 - z + 1}{z - 1} dz$, where C is the contour $|z| = \frac{1}{2}$ is
- (A) $2\pi i$. (B) πi .
 (C) 0. (D) $-2\pi i$.

Ans: C

Because $z = 1$ is a pole for given function f and it lies outside the circle

$|z| = \frac{1}{2}$. Therefore, by Cauchy's Theorem $\int_C f(z) dz = 0$

- Q.32** If X has a Poisson distribution such that $P(X = 2) = 9 P(X = 4) + 90 P(X = 6)$ then the variance of the distribution is
- (A) 1. (B) -1.

(C) 2.

(D) 0.

Ans: A

Because $P(x = 2) = 9 P(x = 4) + 90 P(x = 6)$

$$\Rightarrow \frac{m^2 e^{-m}}{2} = \frac{9 m^4 e^{-m}}{4} + \frac{90 m^6 e^{-m}}{6}$$

$$\Rightarrow \frac{m^2 e^{-m}}{2} \left[\frac{9 m^2}{12} + \frac{m^4}{4} - 1 \right] = 0$$

Because $m \neq 0$, Therefore, $3m^2 + m^4 - 4 = 0$

$$\Rightarrow m = 1$$

Q.33 The vector field function \vec{F} is called solenoidal if

(A) $\text{curl } \vec{F} = 0$.

(B) $\text{div } \vec{F} = 0$.

(C) $\text{grad } \vec{F} = 0$.

(D) $\text{grad div } \vec{F} = 0$.

Ans: B

A vector field \vec{F} is solenoidal if $\text{div } \vec{F} = 0$

Q.34 The number of distinct real roots of $\begin{vmatrix} \sin x & \cos x & \cos x \\ \cos x & \sin x & \cos x \\ \cos x & \cos x & \sin x \end{vmatrix} = 0$ in the interval $-\frac{\pi}{4} \leq x \leq \frac{\pi}{4}$ is

(A) 0.

(B) 2.

(C) 3.

(D) 1.

Ans: D

$$\begin{vmatrix} \sin x & \cos x & \cos x \\ \cos x & \sin x & \cos x \\ \cos x & \cos x & \sin x \end{vmatrix} = 0$$

$$\Rightarrow (\cos x - \sin x)^2 (\sin x + 2 \cos x) = 0$$

Its only root which lies in $-\frac{\pi}{4} \leq x \leq \frac{\pi}{4}$ is $\frac{\pi}{4}$.

Q.35 The solution of : $\frac{dy}{dx} + y \cot x = 2 \cos x$ is

(A) $2y \sin x + \cos 2x = a$.

(B) $2y \sin x + 2x \cos x = a$.

(C) $2y \sin 2x + \cos x = a$.

(D) $2y \cos x - \sin 2x = a$.

Ans: A

$$2y \sin x + \cos 2x = a$$

I.F. $e^{\int \frac{\cos x}{\sin x} dx} = \sin x$

Therefore, the solution is given as

$$y \sin x = \int 2 \cos x \sin x dx = -\frac{\cos 2x}{2} + c$$

$$\Rightarrow 2y \sin x + \cos 2x = a$$

Q.36 If $z = x^4 y^2 \sin^{-1} \frac{x}{y} + \log x - \log y$ then $x \frac{\partial z}{\partial x} + y \frac{\partial z}{\partial y}$ is equal to

(A) $6x^4 y^2 \sin^{-1} \frac{x}{y}$.

(B) $6x^4 \log \frac{x}{y}$.

(C) $(x^2 + y^2) \log \frac{x}{y}$.

(D) $6x^4 y^2 \log \frac{x}{y}$.

Ans: A

$$z = x^4 y^2 \sin^{-1} \frac{x}{y} + \log \frac{x}{y} = u + v$$

where u and v are homogeneous functions of order 6 and 0 respectively. Using Euler's

theorem $\therefore x \frac{\partial z}{\partial x} + y \frac{\partial z}{\partial y} = x \frac{\partial u}{\partial x} + y \frac{\partial u}{\partial y} + x \frac{\partial v}{\partial x} + y \frac{\partial v}{\partial y} = 6u + 0v = 6u$.

Q.37 The value of Legendre's Polynomial, $P_{2m+1}(0)$ is

(A) 1.

(B) -1.

(C) $(-1)^m$.

(D) 0.

Ans: D

By Rodrigue's formula,

$$P_n(0) = 0 \quad \text{if } n \text{ is odd.}$$

Q.38 The value of integral $\iint xy(x+y) dx dy$ over the region bounded by the line $y = x$ and the curve $y = x^2$ is

(A) $\frac{2}{21}$.

(B) $\frac{2}{51}$.

(C) $\frac{3}{56}$.

(D) $\frac{1}{8}$.

(C) $\frac{15}{84}$.

(D) $\frac{69}{84}$.

Ans: B

$P(A) = \frac{3}{7}, \quad P(B) = \frac{7}{12}$. Probability problem will be solved i.e. $P(A \cup B)$

$P(A \cup B) = P(A) + P(B) - P(AB)$

Because A & B are independent, So $P(AB) = P(A) P(B)$

$P(A \cup B) = \frac{3}{7} + \frac{7}{12} - \frac{3}{7} \cdot \frac{7}{12} = \frac{3}{7} + \frac{7}{12} - \frac{3}{12} = \frac{16}{21}$

Q.42 The value of the integral $\iint x \, dx \, dy$ over the area in the first quadrant by the curve

$x^2 - 2ax + y^2 = 0$ is

(A) $\frac{\pi a^2}{2}$.

(B) $\frac{a^3}{3}$.

(C) $\frac{a^2}{2}$.

(D) $\frac{\pi a^3}{2}$.

Ans: D

$\frac{\pi a^3}{2}$

$\iint x \, dx \, dy$ over $x^2 - 2ax + y^2 = 0$

$= \int_{x=0}^{2a} \int_0^{\sqrt{2ax-x^2}} x \, dy \, dx = \int_{x=0}^{2a} x \sqrt{2ax-x^2} \, dx$

$= \int_{x=0}^{2a} x^{3/2} \sqrt{2a-x} \, dx$. Let $x = 2a \sin^2 \theta \Rightarrow dx = 4a \sin \theta \cos \theta \, d\theta$

when $x \rightarrow 0, \theta \rightarrow 0, x \rightarrow 2a, \theta \rightarrow \frac{1}{2}\pi$. Thus $I = 16a^3 \int_0^{\pi/2} \sin^4 \theta \cos^2 \theta \, d\theta = 16a^3 \frac{3}{6} \frac{1}{4} \frac{1}{2} \frac{\pi}{2} = \frac{\pi a^3}{2}$

Q.43 The surface $ax^2 - byz = (a + 2)$ will be orthogonal to the surface $4x^2y + z^3 = 4$ at the point $(1, -1, 2)$ for values of a and b given by

(A) $a = 0.25, b = 1$.

(B) $a = 1, b = 2.5$.

(C) $a = 1.5, b = 2$.

(D) $a = -2.5, b = -1$.

Ans: A

$a = 0.25, b = 1$

$$\therefore J_0(x) = \sum_{m=0}^{\infty} \frac{(-1)^m}{(m!)^2} \left(\frac{x}{2}\right)^{2m}$$

$$\therefore x.J_0(x) = \sum_{m=0}^{\infty} \frac{2(-1)^m}{(m!)^2} \left(\frac{x}{2}\right)^{2m+1}$$

Q.46 The value of integral $\int_{-1}^1 x^3 P_3(x) dx$, where $P_3(x)$ is a Legendre polynomial of degree 3, equals

- (A) $\frac{11}{35}$. (B) 0.
 (C) $\frac{2}{35}$. (D) $\frac{4}{35}$.

Ans: D

$$\text{As } \int_{-1}^1 x^n P_n(x) dx = \frac{2^{n+1} (n!)^2}{(2n+1)}$$

$$\int_{-1}^1 x^3 P_3(x) dx = \frac{2^4 (3!)^2}{7} = \frac{4}{35}$$

Q.47 For what values of x, the matrix $\begin{bmatrix} 3-x & 2 & 2 \\ 2 & 4-x & 1 \\ -2 & -4 & -1-x \end{bmatrix}$ is singular?

- (A) 0, 3 (B) 3, 1
 (C) 1, 0 (D) 1, 4

Ans: A

The matrix is singular if its determinant is zero. Solving determinant, we get equations $x(x-3)^2=0$.

Q.48 If $z = e^{ax+by} f(ax - by)$, then $b \frac{\partial z}{\partial x} + a \frac{\partial z}{\partial y} =$

- (A) 3 ab (B) 2 abz
 (C) abz (D) 3 abz

Ans: B

Because

$$\frac{\partial z}{\partial x} = ae^{ax+by} f(ax-by) + ae^{ax+by} f'(ax-by)$$

$$\frac{\partial z}{\partial y} = be^{ax+by} f(ax-by) - be^{ax+by} f'(ax-by)$$

$$\therefore b \frac{\partial z}{\partial x} + a \frac{\partial z}{\partial y} = 2abe^{ax+by} f(ax-by)$$

Q.49 The value of the integral $\int_{-1}^1 \int_0^z \int_{x-z}^{x+z} (x+y+z) dx dy dz$ is

(A) 2π .

(B) 2.

(C) -2.

(D) 0.

Ans: D

$$\begin{aligned} \int_{z=-1}^1 \int_{x=0}^z \int_{y=x-z}^{x+z} (x+y+z) dy dx dz &= \int_{z=-1}^1 \int_{x=0}^z \left[xy + zy + \frac{y^2}{2} \right]_{x-z}^{x+z} dx dz \\ &= \int_{z=-1}^1 \int_{x=0}^z [2xz + x^2 + 3z^2] dx dz = \int_{-1}^1 \left(\frac{x^3}{3} + 3xz^2 + x^2z \right)_0^z dz = \int_{-1}^1 \frac{13}{3} z^3 dz = 0 \end{aligned}$$

Since it is an odd function.

Q.50 If $u = x^2 + y^2 + z^2$ and $\vec{V} = x \vec{i} + y \vec{j} + z \vec{k}$, then $\text{div} (u\vec{V}) =$

(A) 5

(B) $5u$

(C) $5\vec{V}$

(D) 0

Ans: B

$$\begin{aligned} u\vec{v} &= (y^2 + x^2 + z^2)(x\hat{i} + y\hat{j} + z\hat{k}) \\ \text{div}(u\vec{v}) &= \left(\frac{\partial}{\partial x} \hat{i} + \frac{\partial}{\partial y} \hat{j} + \frac{\partial}{\partial z} \hat{k} \right) (u\vec{v}) \\ &= (y^2 + x^2 + z^2) + 2x^2 + (y^2 + x^2 + z^2) + 2y^2 + 2z^2 + (y^2 + x^2 + z^2) \\ &= 5(y^2 + x^2 + z^2) = 5u \end{aligned}$$

Q.51 The solution of the differential equation $\frac{dz}{dx} + \frac{z}{x} \log z = \frac{z}{x} (\log z)^2$ is given as

(A) $(\log z)^{-1} = 1 + cx$

(B) $\log z = 1 + cx$

(C) $\log z(1 + ex) = c$

(D) $\log z = (1 + cx)^{-2}$

Ans: A

Dividing by z, we get

$$\frac{1}{z} \frac{dz}{dx} + \frac{\log z}{x} = \frac{(\log z)^2}{x},$$

Let $1/(\log z)=u$, then above differential equation becomes

$$\frac{du}{dx} - \frac{u}{x} = -\frac{1}{x}$$

$$I.F. = e^{-\int \frac{1}{x} dx} = \frac{1}{x}$$

$$\therefore \frac{u}{x} = \int -\frac{1}{x^2} dx + c \Rightarrow \frac{u}{x} = \frac{1}{x} + c \Rightarrow (\log z)^{-1} = 1 + cx$$

- Q.52** The value of the integral $\int_C \frac{z^2 - z + 1}{z - 1} dz$, where C is the circle $|z| = \frac{1}{2}$ is given as
- (A) 2π (B) $2\pi i$
 (C) 0 (D) $-2\pi i$

Ans: C

The given function has a pole at $z=1$, which lies outside the circle C. So by Cauchy's theorem integral is zero.

- Q.53** The value of the Legendre's polynomial $\int_{-1}^1 P_m(x)P_n(x) dx = \frac{2}{2n+1}$ if
- (A) $m \neq n$ (B) $m > n$
 (C) $m < n$ (D) $m = n$

Ans: D

By orthogonal property of Legendre's polynomial.

- Q.54** Two persons A and B toss an unbiased coin alternately on the understanding that the first who gets the head wins. If A starts the game, then his chances of winning is
- (A) $\frac{1}{2}$ (B) $\frac{1}{3}$
 (C) $\frac{2}{3}$ (D) $\frac{1}{4}$

Ans: C

Probability of getting head= $1/2$ = probability of getting tail.

If A starts the game, then in first chance either A wins the game, in second case A fails, B fails and A won the match and so on, we get an infinite series. Let H_A, H_B, T_A, T_B , denotes the getting of head and tails by A and B respectively.

$$\begin{aligned}
 P(\text{winning of A}) &= P(H_A) + P(T_A T_B H_A) + P(T_A T_B T_A T_B H_A) + \dots \\
 &= \frac{1}{2} + \left(\frac{1}{2}\right)^3 + \left(\frac{1}{2}\right)^5 + \dots
 \end{aligned}$$

This is an infinite G.P. series with common ratio 1/4. Thus

$$P(\text{winning of A}) = \frac{1}{2} \left[\frac{1}{1 - \left(\frac{1}{2}\right)^2} \right] = \frac{2}{3}.$$

Q.55 The value of limit $\lim_{(x,y) \rightarrow (0,0)} \frac{x^2 y}{x^4 + y^2}$

- (A) equals 0.
- (B) equals $\frac{1}{2}$.
- (C) equals 1.
- (D) does not exist.

Ans: D

Let $y = mx^2$ be equation of curve. As $x \rightarrow 0$, y also tends to zero.

$$\begin{aligned}
 f(x, y) &= \frac{x^2 y}{x^4 + y^2} \\
 &= \frac{m}{1 + m^2}
 \end{aligned}$$

$$\lim_{x \rightarrow 0} f(x, mx^2) = \lim_{x \rightarrow 0} \frac{m}{1 + m^2} = \frac{m}{1 + m^2}, \text{ which depends on } m.$$

Thus it does not exist.

Q.56 If $u = x^2 - y^2, v = xy$ then $\frac{\partial x}{\partial u}$ equals

- (A) $\frac{x}{2(x^2 + y^2)}$.
- (B) $\frac{y}{2(x^2 + y^2)}$.
- (C) $\frac{y}{x^2 + y^2}$.
- (D) $\frac{x}{x^2 + y^2}$.

Ans: A

$$u = x^2 - y^2 \Rightarrow 1 = 2xx_u - 2yy_u$$

$$v = xy \Rightarrow 0 = yx_u + xy_u$$

Eliminating y_u we get

$$x_u = \frac{\partial x}{\partial u} = \frac{x}{2(x^2 + y^2)}$$

- Q.57** The function $f(x, y) = y^2 - x^3$ has
- (A) a minimum at (0, 0).
 - (B) neither minimum nor maximum at (0, 0).
 - (C) a minimum at (1, 1).
 - (D) a maximum at (1, 1).

Ans: B

$$f(x, y) = y^2 - x^3$$

$$f_x = -3x^2 = 0, \quad f_y = 2y = 0$$

gives (0,0) is a critical point.

$$\Delta f(x, y) = f(\Delta x, \Delta y) - f(x, y) = (\Delta y)^2 - (\Delta x)^3$$

$$> 0, \quad \text{if } (\Delta y)^2 > (\Delta x)^3$$

$$< 0, \quad \text{if } (\Delta y)^2 < (\Delta x)^3$$

This means in the neighborhood of (0,0) f changes sign. Thus (0,0) is neither a point of maximum nor minimum.

- Q.58** The family of orthogonal trajectories to the family $y(x - k)^2$, where k is an arbitrary constant, is

- (A) $y^{3/2} = \frac{3}{4}(c - x)$.
- (B) $x^{3/2} = (y - c)^2$.
- (C) $(y - c)^2 = \frac{3}{4}x$.
- (D) $y^2 = \frac{3}{2}(c - x)$.

Ans: A

$$y = (x - k)^2 \quad \text{Diff. w.r.t. } x$$

$$y_1 = 2(x - k) \Rightarrow y_1 = 2\sqrt{y}$$

For orthogonal trajectories y_1 is replaced by $-1/y_1$.

$$\text{Therefore, } -1/y_1 = 2\sqrt{y}$$

- Q.65** If $z = \sin^{-1} \frac{x^2 + y^2}{x + y}$, then the value of $x \frac{\partial z}{\partial x} + y \frac{\partial z}{\partial y}$ is
- (A) z (B) $2z$
 (C) $\tan(z)$ (D) $\sin(z)$

Ans.: C

If $u(x,y) = x^n + \left(\frac{y}{x}\right)$, is a homogeneous function of degree n, then from Euler's theorem

$$x \frac{\partial u}{\partial x} + y \frac{\partial u}{\partial y} = nu.$$

Here $u = \sin z = \frac{x^2 + y^2}{x + y} = \frac{x^2 \left(1 + \frac{y^2}{x^2}\right)}{x \left(1 + \frac{y}{x}\right)}$ is a homogeneous function of degree 1.

Therefore $x \frac{\partial u}{\partial x} + y \frac{\partial u}{\partial y} = 1. u = \sin z$

From $u = \sin z; \frac{\partial u}{\partial x} = \cos z \cdot \frac{\partial z}{\partial x}, \frac{\partial u}{\partial y} = \cos z \cdot \frac{\partial z}{\partial y}.$

$$\therefore x \frac{\partial z}{\partial x} + y \frac{\partial z}{\partial y} = \frac{\sin z}{\cos z} = \tan z$$

- Q.66** The value of integral $\int_0^1 \int_{x^2}^{1-2x} xy \, dx \, dy$ is equal to

- (A) $\frac{3}{4}$ (B) $\frac{3}{8}$
 (C) $\frac{3}{5}$ (D) $\frac{3}{7}$

Ans.: B

$$\int_0^1 \int_{x^2}^{1-2x} xy \, dx \, dy = \int_0^1 \frac{1}{2} \left[xy^2 \right]_{x^2}^{1-2x} dx = \int_0^1 \frac{1}{2} (4x + x^3 - 4x^2 - x^5) dx = \left[x^2 + \frac{x^4}{8} - \frac{2x^3}{3} - \frac{x^6}{12} \right]_0^1 = \frac{3}{8}$$

- Q.67** The differential equation of a family of circles having the radius r and the centre on the x-axis is given by

- (A) $y^2 \left(1 + \left(\frac{dy}{dx}\right)^2\right) = r^2$ (B) $x^2 \left(1 + \left(\frac{dy}{dx}\right)^2\right) = r^2$
 (C) $r^2 \left(1 + \left(\frac{dy}{dx}\right)^2\right) = x^2$ (D) $(x^2 + y^2) \left(1 + \left(\frac{dy}{dx}\right)^2\right) = r^2$

Ans.: A

Let $(h,0)$ be centre on x-axis. Thus eq. of circle is $(x-h)^2 + y^2 = r^2$

Differentiating, w.r. to x, we get $2(x-h) + 2y \frac{dy}{dx} = 0$

Eliminating h between $(x-h)^2 + y^2 = r^2$ and $x-h = -y \frac{dy}{dx}$

We get $y^2 \left(\frac{dy}{dx} \right)^2 + y^2 = r^2$.

- Q.68** The solution of the differential equation $\frac{d^2y}{dx^2} + y = 0$ satisfying the initial conditions $y(0)=1, y(\pi/2) = 2$ is
- | | |
|------------------------------|-------------------------------|
| (A) $y = 2\cos(x) + \sin(x)$ | (B) $y = \cos(x) + 2\sin(x)$ |
| (C) $y = \cos(x) + \sin(x)$ | (D) $y = 2\cos(x) + 2\sin(x)$ |

Ans.: B

On solving the differential equation $\frac{d^2y}{dx^2} + y = 0$ we get $y = A\cos x + B\sin x$, Since

$y(0)=1, \Rightarrow A = 1, y(\frac{\pi}{2}) = 2 \Rightarrow B = 2$. Thus, $y = \cos(x) + 2\sin x$

- Q.69** If the matrix $A = \begin{pmatrix} 1 & 0 \\ 0 & 1 \end{pmatrix}, B = \begin{pmatrix} 0 & 1 \\ -1 & 0 \end{pmatrix}, C = \begin{pmatrix} \cos \theta & \sin \theta \\ -\sin \theta & \cos \theta \end{pmatrix}$ then
- | | |
|---------------------------------------|---------------------------------------|
| (A) $C=A\cos(\theta) - B\sin(\theta)$ | (B) $C=A\sin(\theta) + B\cos(\theta)$ |
| (C) $C=A\sin(\theta) - B\cos(\theta)$ | (D) $C=A\cos(\theta) + B\sin(\theta)$ |

Ans.: D

$$C = \begin{pmatrix} \cos \theta & \sin \theta \\ -\sin \theta & \cos \theta \end{pmatrix} = \cos \theta \begin{pmatrix} 1 & 0 \\ 0 & 1 \end{pmatrix} + \sin \theta \begin{pmatrix} 0 & 1 \\ -1 & 0 \end{pmatrix} = A \cos \theta + B \sin \theta$$

- Q.70** The three vectors $(1,1,-1,1), (1,-1,2,-1)$ and $(3,1,0,1)$ are
- | | |
|--------------------------|------------------------|
| (A) linearly independent | (B) linearly dependent |
| (C) null vectors | (D) none of these. |

Ans.: B

Let a,b,c be three constants such that $a(1,1,-1,1)+b(1,-1,2,-1)+c(3,1,0,1)=(0,0,0,0)$.

This yields $a + b + 3c = 0, a - b + c = 0, -a + 2b = 0, a - b + c = 0$.

On solving, we get $a = 2b = -2c \rightarrow b = -c$. Since a, b, c are non-zero, therefore three vectors are linearly dependent.

- Q.71** The value of $\int_{-1}^1 P_3(x) P_4(x) dx$ is equal to

- (A) 1 (B) 0
 (C) $\frac{2}{9}$ (D) $\frac{2}{7}$

Ans.: B

$$\int_{-1}^1 P_m(x) P_n(x) dx = \begin{cases} 0 & \text{if } m \neq n \\ \frac{2}{2n+1} & \text{if } m = n \end{cases}$$

Q.72 The value of the integral $\int \frac{1}{x} J_2(x) dx$ is

- (A) $\frac{1}{x} J_1(x) + c$ (B) $\frac{1}{x} J_{-1}(x) + c$
 (C) $-\frac{1}{x} J_1(x) + c$ (D) $J_1(x) + c$

Ans.: C

As $\int x^{-v} J_{v+1}(x) dx = -x^{-v} J_v(x) + c$. Here $v=1$.

Q.73 The value of limit $\lim_{(x,y) \rightarrow (0,0)} \frac{x + \sqrt{y}}{\sqrt{x^2 + y}}$ is

- (A) limit does not exist (B) 0
 (C) 1 (D) -1

Ans.: A

Consider the path $y = mx^2$ As $(x,y) \rightarrow (0,0)$, we get $x \rightarrow 0$. Therefore

$\lim_{(x,y) \rightarrow (0,0)} \frac{x + \sqrt{y}}{\sqrt{x^2 + y}}$ which depends on m . Thus limit does not exist.

Q.74 If $u = x^y$ then the value of $\frac{\partial u}{\partial y}$ is equal to

- (A) 0 (B) $x^y \log(x)$
 (C) xy^{x-1} (D) yx^{y-1}

Ans.: B

Since $u = x^y$, taking log on both sides we get $\log(u) = y \log(x)$

$$\frac{1}{u} \frac{\partial u}{\partial x} = \frac{y}{x} \Rightarrow \frac{\partial u}{\partial x} = yx^{y-1}$$

Q.75 If $u = \sin^{-1}\left(\frac{x}{y}\right) + \tan^{-1}\left(\frac{y}{x}\right)$, then the value of $x \frac{\partial u}{\partial x} + y \frac{\partial u}{\partial y}$ is

- (A) u (B) 2u

- (C) 3u (D) 0

Ans.: D

Let $u = \sin^{-1} \frac{x}{y} + \tan^{-1} \frac{y}{x} = v + w \rightarrow z_1 = \sin v = \frac{x}{y}, z_2 = \tan w = \frac{y}{x}$

Here z_1 and z_2 are homogenous functions of degree zero.

Consequently $x \frac{\partial z_1}{\partial x} + y \frac{\partial z_1}{\partial y} = 0 \rightarrow x \cos u \frac{\partial u}{\partial x} + y \cos v \frac{\partial v}{\partial y} = 0$

Or $x \frac{\partial v}{\partial x} + y \frac{\partial v}{\partial y} = 0$; similarly $x \frac{\partial w}{\partial x} + y \frac{\partial w}{\partial y} = 0$.

$$\frac{\partial u}{\partial x} = \frac{\partial v}{\partial x} + \frac{\partial w}{\partial x}; \frac{\partial u}{\partial y} = \frac{\partial v}{\partial y} + \frac{\partial w}{\partial y}$$

$$\therefore x \frac{\partial u}{\partial x} + y \frac{\partial u}{\partial y} = \left(x \frac{\partial v}{\partial x} + y \frac{\partial v}{\partial y} \right) + \left(x \frac{\partial w}{\partial x} + y \frac{\partial w}{\partial y} \right) = 0 + 0 = 0.$$

Q.76 The value of integral $\int_0^2 \int_1^3 \int_1^2 xy^2z \, dx \, dy \, dz$ is equal to

- (A) 22 (B) 26
(C) 5 (D) 25

Ans.: B $\int_0^2 \int_1^3 \int_1^2 xy^2z \, dx \, dy \, dz = \int_0^2 x dx \int_1^3 y^2 dy \int_1^2 z dz = 2 \cdot \frac{26}{3} \cdot \frac{3}{2} = 26$

Q.77 The solution of the differential equation $(y+x)^2 \frac{dy}{dx} = a^2$ is given by

- (A) $y+x = a \tan\left(\frac{y-c}{a}\right)$ (B) $y-x = \tan\left(\frac{y-c}{a}\right)$
(C) $y-x = a \tan(y-c)$ (D) $a(y-x) = \tan\left(y-\frac{c}{a}\right)$

Ans.: A

Let $x + y = t$, Differentiating w r to x we get

$$1 + \frac{dy}{dx} = \frac{dt}{dx} \rightarrow t^2 \left(\frac{dt}{dx} - 1 \right) = a^2 \rightarrow \frac{dt}{dx} = \frac{a^2}{t^2} + 1$$

Or $\frac{dt}{dx} = \frac{a^2 + t^2}{t^2}$ or $\frac{t^2}{a^2 + t^2} dt = dx = \frac{a^2 + t^2 - a^2}{a^2 + t^2} dt$,

$$\frac{dt}{1} = \frac{a^2}{a^2 + t^2} dt = dx; \text{ integrating we get}$$

$$t - a^2 \frac{1}{a} \tan^{-1} \frac{t}{a} = x + c \rightarrow x + y = a \tan^{-1} \frac{x+y}{a} + x + c$$

Or $y = a \tan^{-1} \frac{x+y}{a} + c$ or $a \tan \frac{y-c}{a} = x+y$.

Q.78 The solution of the differential equation $\frac{d^2y}{dx^2} - 3\frac{dy}{dx} + 2y = e^{3x}$ is

(A) $y = ae^x + be^{2x} + \frac{1}{2}e^{3x}$ (B) $y = ae^{-x} + be^{-2x} + \frac{1}{2}e^{3x}$

(C) $y = ae^x + be^{-2x} + \frac{1}{2}e^{3x}$ (D) $y = ae^{-x} + be^{2x} + \frac{1}{2}e^{3x}$

Ans.: A

The solution of differential equation $\frac{d^2y}{dx^2} - 3\frac{dy}{dx} + 2y = e^{3x}$ is given as C.F.

$$y = ae^x + be^{2x} \text{ P.I.} = \frac{1}{(D^2 - 3D + 2)} e^{3x} = \frac{1}{2} e^{3x} \quad y = ae^x + be^{2x} + \frac{1}{2} e^{3x}$$

In writing the C.F. we have used the roots of the auxiliary equation $m^2 - 3m + 2 = 0$

i.e. $m = 1, 2$. For writing the P.I we have used $\frac{1}{f(D)} e^{ax} = \frac{1}{f(a)} e^{ax}$; $f(a) \neq 0$

Q.79 If $3x+2y+z=0$, $x+4y+z=0$, $2x+y+4z=0$, be a system of equations then

- (A) system is inconsistent
- (B) it has only trivial solution
- (C) it can be reduced to a single equation thus solution does not exist
- (D) Determinant of the coefficient matrix is zero.

Ans. B

$|A| = 34 \neq 0$, then system has only trivial solution.

Q.80 If λ is an eigen value of a non-singular matrix A then the eigen value of A^{-1} is

- (A) $1/\lambda$ (B) λ
- (C) $-\lambda$ (D) $-1/\lambda$

Ans. A By definition of A^{-1} .

Q.81 The product of eigen value of the matrix $A = \begin{bmatrix} 1 & 0 & 0 \\ 0 & 3 & -1 \\ 0 & -1 & 3 \end{bmatrix}$ is

- (A) 3 (B) 8
- (C) 1 (D) -1

Ans.: B

$$A - \lambda I = \begin{bmatrix} 1-\lambda & 0 & 0 \\ 0 & 3-\lambda & -1 \\ 0 & -1 & 3-\lambda \end{bmatrix} = (1-\lambda) \left[(3-\lambda)^2 - 1 \right] = 0 \text{ Eigen values are } 1, 2, 4.$$

Thus product = 8.

Q.82 The value of the integral $\int x^2 J_1(x) dx$ is

- (A) $x^2 J_1(x) + c$ (B) $x^2 J_{-1}(x) + c$
 (C) $x^2 J_2(x) + c$ (D) $x^2 J_{-2}(x) + c$

Ans.: C As $\int x^v J_{v-1}(x) dx = x^v J_v(x) + c$. Here $v=2$.

Q.83 If $u = f(y/x)$, then

- (A) $x \frac{\partial u}{\partial x} - y \frac{\partial u}{\partial y} = 0$ (B) $x \frac{\partial u}{\partial x} + y \frac{\partial u}{\partial y} = 0$
 (C) $x \frac{\partial u}{\partial x} + y \frac{\partial u}{\partial y} = 2u$ (D) $x \frac{\partial u}{\partial x} + y \frac{\partial u}{\partial y} = 1$

Ans.: B

Since $u = f(y/x)$, is a homogeneous function of degree 0. Thus by Euler's theorem

$$x \frac{\partial u}{\partial x} + y \frac{\partial u}{\partial y} = 0.$$

Q.84 If $x = r \cos \theta$, $y = r \sin \theta$, then the value of $\frac{\partial(x, y)}{\partial(r, \theta)}$ is

- (A) 1 (B) r
 (C) 1/r (D) 0

Ans.: B

$$\frac{\partial(x, y)}{\partial(r, \theta)} = \begin{vmatrix} \frac{\partial x}{\partial r} & \frac{\partial x}{\partial \theta} \\ \frac{\partial y}{\partial r} & \frac{\partial y}{\partial \theta} \end{vmatrix} = \begin{vmatrix} \cos \theta & -r \sin \theta \\ \sin \theta & r \cos \theta \end{vmatrix} = r$$

Q.85 The value of integral $\int_0^2 \int_0^x (x+y) dx dy$ is equal to

- (A) -4 (B) 3
 (C) 4 (D) -3

Ans.: C

$$\int_0^2 \int_0^x (x+y) dx dy = \int_0^2 \left[xy + \frac{y^2}{2} \right]_0^x dx = \int_0^2 \frac{3}{2} x^2 dx = 4$$

- Q.86** The solution of differential equation $\frac{dy}{dx} + \frac{y}{x} = x^2$ under condition $y(1)=1$ is given by
- (A) $4xy = x^3 + 3$ (B) $4xy = x^4 + 3$
 (C) $4xy = y^4 + 3$ (D) $4xy = y^3 + 3$

Ans.: B

The given differential is a particular case of linear differential equation of first order

$$\frac{dy}{dx} + P(x)y = Q(x). \text{ Here } P(x) = \frac{1}{x}, Q(x) = x^2$$

I.F. = $e^{\int P dx} = e^{\int \frac{1}{x} dx} = e^{\log x} = x$. Multiplying throughout by x, it can be written as

$$\frac{d}{dx}(xy) = x^3; \text{ Integrating w.r. to x we get}$$

$$xy = \frac{x^4}{4} + C; \text{ Given } y(1) = 1; \rightarrow 1 = \frac{1}{4} + C \rightarrow C = \frac{3}{4}$$

$$\therefore xy = \frac{x^4}{4} + \frac{3}{4} \text{ or } 4xy = x^4 + 3 \text{ which is alternative B.}$$

- Q.87** The particular integral of the differential equation $\frac{d^2y}{dx^2} + a^2y = \sin ax$ is
- (A) $-\frac{x}{2a} \cos ax$ (B) $\frac{x}{2a} \cos ax$
 (C) $-\frac{ax}{2} \cos ax$ (D) $\frac{ax}{2} \cos ax$

Ans.: A

P.I. $\frac{1}{D^2 + a^2} \sin ax$ is a case of failure of $\frac{1}{f(D^2)} \sin ax = \frac{\sin ax}{f(-a^2)}$; $f(-a^2) = 0$

In such cases $\frac{1}{f(D^2)} \sin ax = \frac{x}{f'(D)} \sin ax = \frac{x}{2D} \sin ax = -\frac{x}{2a} \cos ax$.

- Q.88** The product of the eigen values of $\begin{pmatrix} 1 & 0 & 0 \\ 0 & 3 & -1 \\ 0 & -1 & 3 \end{pmatrix}$ is equal to
- (A) 6 (B) -8
 (C) 8 (D) -6

Ans.: C

$$\begin{pmatrix} 1-\lambda & 0 & 0 \\ 0 & 3-\lambda & -1 \\ 0 & -1 & 3-\lambda \end{pmatrix} = (1-\lambda)[(3-\lambda)^2 - 1] = (1-\lambda)(\lambda^2 - 6\lambda + 8) = 0.$$

The eigenvalues are 1,2,4. Thus product of eigen values = 8.

Q.89 If $A \begin{bmatrix} 0 & 1 \\ 2 & -1 \end{bmatrix} = \begin{bmatrix} 2 & 1 \\ -1 & 0 \end{bmatrix}$ then matrix A is equal to

- (A) $\begin{bmatrix} 2 & 1 \\ 0 & 0 \end{bmatrix}$ (B) $\begin{bmatrix} 0 & 1 \\ 2 & -1 \end{bmatrix}$
 (C) $\begin{bmatrix} 2 & 1 \\ -1 & 0 \end{bmatrix}$ (D) $\begin{bmatrix} 2 & 1 \\ -1/2 & -1/2 \end{bmatrix}$

Ans.: D

$$\begin{aligned} A \begin{bmatrix} 0 & 1 \\ 2 & -1 \end{bmatrix} &= \begin{bmatrix} 2 & 1 \\ -1 & 0 \end{bmatrix} \Rightarrow A = \begin{bmatrix} 2 & 1 \\ -1 & 0 \end{bmatrix} \begin{bmatrix} 0 & 1 \\ 2 & -1 \end{bmatrix}^{-1} \\ &= \begin{bmatrix} 2 & 1 \\ -1 & 0 \end{bmatrix} \begin{bmatrix} 1/2 & 1/2 \\ 1 & 0 \end{bmatrix} = \begin{bmatrix} 2 & 1 \\ -1/2 & -1/2 \end{bmatrix} \end{aligned}$$

Q.90 The value of $\int_{-1}^1 x^m P_n(x) dx$ (m being an integer < n) is equal to
 (A) 1 (B) -1
 (C) 2 (D) 0

Ans.: D

Using Rodrigue formula $\int_{-1}^1 x^m P_n(x) dx$ can be expressed as

$$(-1)^m \frac{m!}{2^n n!} \left[D^{n-m-1} (x^2 - 1)^n \right]_{-1}^1 = 0, m < n$$

Q.91 The value of the $J_{-1/2}(x)$ is

- (A) $\sqrt{(2/\pi x)} \cos x$ (B) $\sqrt{(2/\pi x)} \sin x$
 (C) $\sqrt{(1/\pi x)} \cos x$ (D) $\sqrt{(2/\pi)} \cos x$

Ans.: A

$$J_{-1/2}(x) = \frac{x^{-1/2}}{2^{-1/2} \Gamma(\frac{1}{2})} \left[1 - \frac{x^2}{2} + \frac{x^4}{2.3.4} - \dots \right] = \sqrt{(2/\pi x)} \cos x.$$

PART – II

NUMERICALS

Q.1 Consider the function $f(x, y)$ defined by

$$f(x, y) = \begin{cases} (x^2 + y^2) \sin \frac{1}{\sqrt{x^2 + y^2}}, & \text{if } (x, y) \neq (0,0); \\ 0, & \text{if } (x, y) = (0,0). \end{cases}$$

Find $f_x(0,0)$ and $f_y(0,0)$.

Is $f(x, y)$ differentiable at $(0, 0)$? Justify your answer. (8)

Ans:

$$f(x, y) = \begin{cases} (x^2 + y^2) \sin \frac{1}{\sqrt{x^2 + y^2}}, & (x, y) \neq (0,0) \\ 0 & , (x, y) = (0,0) \end{cases}$$

The partial derivatives are

$$\begin{aligned} f_x(0,0) &= \lim_{h \rightarrow 0} \frac{f(h,0) - f(0,0)}{h} \\ &= \lim_{h \rightarrow 0} h \sin \frac{1}{h} \\ &= 0 \end{aligned}$$

$$\begin{aligned} f_y(0,0) &= \lim_{k \rightarrow 0} \frac{f(0,k) - f(0,0)}{k} \\ &= \lim_{k \rightarrow 0} k \sin \frac{1}{k} \\ &= 0. \end{aligned}$$

Therefore, $df = 0$ {as $df = f_x dx + f_y dy$ }

Let $dx = r \cos\theta$ $dy = r \sin\theta$ }
 $\Delta\rho = \sqrt{(dx)^2 + (dy)^2} = r$

$$\begin{aligned} \lim_{\Delta\rho \rightarrow 0} \frac{\Delta f - df}{\Delta\rho} &= \lim_{r \rightarrow 0} \frac{f(r \cos\theta, r \sin\theta) - 0}{r} \\ &= \lim_{r \rightarrow 0} r \sin \frac{1}{r} \\ &= 0. \end{aligned}$$

$\therefore f(X,Y)$ is differentiable.

Q.2 Find the extreme values of $f(x, y, z) = x^2 + 2xy + z^2$ subject to the constraints of $(x, y, z) = 2x + y = 0$ and $h(x, y, z) = x + y + z = 1$ (8)

Ans:

Consider the Auxiliary function

$$F(x, y, z) = x^2 + 2xy + z^2 + \lambda_1(2x + y) + \lambda_2(x + y + z - 1)$$

For the extremum, we have the necessary conditions

$$\frac{\partial F}{\partial x} = 2x + 2y + 2\lambda_1 + \lambda_2 = 0 \quad \text{-----(1)}$$

$$\frac{\partial F}{\partial y} = 2x + \lambda_1 + \lambda_2 = 0 \quad \text{-----(2)}$$

$$\frac{\partial F}{\partial z} = 2z + \lambda_2 = 0 \quad \text{-----(3)}$$

$$2x + y = 0 \quad \text{-----(4)}$$

$$x + y + z - 1 = 0 \quad \text{-----(5)}$$

From (4) we get $y = -2x$.

Taking $y = -2x$ in (1), we get $-2x + 2\lambda_1 + \lambda_2 = 0$ ------(6)

(2) & (6) implies $3\lambda_1 + 2\lambda_2 = 0$ ------(7)

From (5) $x + y = 1 - z$. putting this in (1), we get $2 - 2z + 2\lambda_1 + \lambda_2 = 0$ -----(8)

(3) and (8) implies $2\lambda_1 + 2\lambda_2 = -2$ ------(9)

(7) and (9) implies $\lambda_1 = 2, \lambda_2 = -3$

$$z = \frac{-\lambda_2}{2} = \frac{3}{2}$$

$$x = \frac{-1}{2}(\lambda_1 + \lambda_2) = \frac{1}{2}$$

$$y = -2x = -1$$

The point of extremum is $\left(\frac{1}{2}, -1, \frac{3}{2}\right)$

The extremum value is $f\left(\frac{1}{2}, -1, \frac{3}{2}\right) = \frac{1}{4} + (-1) + \frac{9}{4} = \frac{6}{4} = \frac{3}{2}$

Q.3 Find all critical points of $f(x, y) = (x^2 + y^2)e^{4x+2y^2}$ and determine relative extrema at these critical points. (8)

Ans:

$$f_x(x, y) = (x^2 + y^2) e^{4x+2x^2} \cdot (4 + 4x) + e^{4x+2x^2} \cdot 2x$$

$$f_y(x, y) = e^{4x+2x^2} 2y$$

$$f_y(x, y) = 0 \Rightarrow y = 0$$

$$\text{and } f_x(x, 0) = x^2 e^{4x+2x^2} (4 + 4x) + 2xe^{4x+2x^2}$$

$$= 2xe^{4x+2x^2} (1 + 2x^2 + 2x)$$

$$= 0 \Rightarrow \text{either } x = 0 \text{ or } 1 + 2x + 2x^2 = 0$$

\therefore The only critical point is $(x, y) = (0, 0)$

$$f_{xx}(x, y) = 4(x^2 + y^2)e^{4x+2x^2} + (x^2 + y^2)(4 + 4x)^2 e^{4x+2x^2} \\ + 2e^{4x+2x^2} + 2x(4 + 4x)e^{4x+2x^2}$$

$$\therefore f_{xx}(0, 0) = 0 + 0 + 2 + 0 = 2$$

$$f_{yy}(x, y) = 2e^{4x+2x^2}$$

$$\therefore f_{yy}(0, 0) = 2$$

$f_{xy} = f_{yx}$ as the function $f(x, y)$ has partial derivatives of order two and they are continuous.

$$\therefore f_{yx} = 2e^{4x+2x^2} \cdot y = (4 + 4x)$$

$$f_{yx}(0, 0) = 0$$

$$\text{Now } f_{xx}(0, 0) = 2 > 0 \text{ and}$$

$$f_{xx} f_{yy} - (f_{xy})^2 = 4 > 0$$

$\therefore (0, 0)$ is a point of local minimum.

Q.4 Find the second order Taylor expansion of $f(x, y) = \sin\left[\left(x^2 + 1\right)y\right]$ about the point $(0, \pi/2)$.

(4)

Ans:

$$f(x, y) = \sin\left((x^2 + 1)y\right)$$

Second order Taylor expansion of $f(x, y)$ is

$$f(x, y) = f(a, b) + (x - a)f_x(a, b) + (y - b)f_y(a, b) + \frac{(x - a)^2}{2} f_{xx}(a, b) + \frac{(y - b)^2}{2} f_{yy}(a, b) + (x - a)(y - b)f_{xy}(a, b)$$

$$\left. \begin{aligned} f_x(x, y) &= \cos[(x^2 + 1)y] 2xy \\ f_{xx}(x, y) &= 2y \cos[(x^2 + 1)y] - 4x^2 y^2 \sin[(x^2 + 1)y] \\ f_y(x, y) &= \cos[(x^2 + 1)y] (x^2 + 1) \\ f_{yy}(x, y) &= -(x^2 + 1)^2 \sin[(x^2 + 1)y] \\ f_{xy}(x, y) &= -\sin[(x^2 + 1)y] (x^2 + 1)2xy + 2x \cos[(x^2 + 1)y] \end{aligned} \right\}$$

$$\therefore f\left(0, \frac{\pi}{2}\right) = \sin \frac{\pi}{2} = 1$$

$$f_x\left(0, \frac{\pi}{2}\right) = 0$$

$$f_y\left(0, \frac{\pi}{2}\right) = 0$$

$$f_{xx}\left(0, \frac{\pi}{2}\right) = \pi \cdot 0 - 0 = 0$$

$$f_{yy}\left(0, \frac{\pi}{2}\right) = -\sin \frac{\pi}{2} = -1$$

$$f_{xy}\left(0, \frac{\pi}{2}\right) = -0 + 0 = 0$$

$$f(x, y) = 1 + \frac{x}{1} \cdot 0 + \left(y - \frac{\pi}{2}\right) \cdot 0 + \frac{x^2}{2} \cdot 0 + \left(y - \frac{\pi}{2}\right)^2 (-1)$$

$$\therefore f(x, y) = 1 - \left(y - \frac{\pi}{2}\right)^2$$

Q.5 Change the order of integration in the following double integral and evaluate it :

$$\int_0^1 \int_y^1 x^2 e^{xy} dx dy \tag{4}$$

Ans:

The region of integration is given by $y \leq x \leq 1$ and $0 \leq y \leq 1$.
Hence, it is bounded by the straight lines $x = y$ and $x = 1$ between $y = 0$ and $y = 1$.

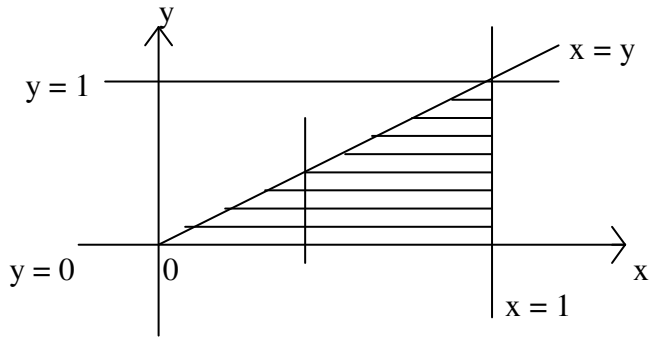

To find the limits of integration in the reverse order, we observe that the region is

Also given by $0 \leq y \leq x$ and $0 \leq x \leq 1$

Hence,

$$\begin{aligned} & \int_0^1 \int_y^1 x^2 e^{xy} dx dy \\ &= \int_0^1 \int_0^x x^2 e^{xy} dy dx = \int_0^1 x^2 \left[\int_0^x e^{xy} dy \right] dx \\ &= \int_0^1 x^2 \left[\frac{e^{xy}}{x} \right]_0^x dx = \int_0^1 x \left(e^{x^2} - 1 \right) dx \\ &= \int_0^1 x e^{x^2} dx - \int_0^1 x dx = \int_0^1 e^t \frac{dt}{2} - \int_0^1 x dx \\ &= \frac{e-1}{2} - \frac{1}{2} = \frac{e-2}{2} \end{aligned}$$

Q.6 Solve the differential equation $\frac{dy}{dx} + y = xy^3$. (4)

Ans:

$$\frac{dy}{dx} + y = xy^3 \quad \text{or} \quad y' + y = xy^3$$

This is Bernoulli Equation with $p(x) = 1$ $q(x) = x$ and $k = 3$

in $y' + p(x)y = q(x)y^k$

Take the transformation $z = y^{-2}$

$$\begin{aligned} \text{Then } \frac{dz}{dx} &= -2y^{-3} \left(\frac{dy}{dx} \right) \\ &= -2y^{-3} (xy^3 - y) \\ &= -2x + 2y^{-2} \\ &= -2x + 2z \end{aligned}$$

$$\text{Therefore, } \frac{dz}{dx} - 2z = -2x$$

This is linear equation of 1st order

$$\text{I.F.} = e^{-\int 2dx} = e^{-2x}$$

Solution is

$$z \cdot e^{-2x} = -2 \int x e^{-2x} dx + c.$$

$$z e^{-2x} = x e^{-2x} + \frac{1}{2} e^{-2x} + c.$$

Therefore $z = \frac{1}{y^2} = x + \frac{1}{2} + c e^{2x}$ is the solution.

Q.7 Solve the differential equation $\frac{y^{3/2} + 1}{x^{1/2}} dx + (3x^{1/2} y^{1/2} - 1) dy = 0.$ (6)

Ans:

$$\text{let } M = \frac{y^{3/2} + 1}{x^{1/2}} \quad \text{and} \quad N = 3x^{1/2} y^{1/2} - 1 \quad \text{-----(1)}$$

$$\frac{\partial M}{\partial y} = \frac{3}{2} y^{1/2} x^{-1/2} \quad \text{and} \quad \frac{\partial N}{\partial x} = \frac{3}{2} x^{-1/2} y^{1/2}$$

$$\frac{\partial M}{\partial y} = \frac{\partial N}{\partial x} \quad \text{Hence the equations is exact.}$$

$$\begin{aligned}
 f(x, y) &= \int M dx + \phi(y) \\
 &= \int \left(\frac{3}{y^2 + 1} \right) x^{-\frac{1}{2}} dx + \phi(y) \\
 &= 2x^{\frac{1}{2}} \left(\frac{3}{y^2 + 1} \right) + \phi(y) \quad \text{-----(2)}
 \end{aligned}$$

From the relation $f_y(x, y) = N(x, y)$

∴ From (1) and (2) above, we get

$$\frac{1}{3x^2} \frac{1}{y^2} + \phi'(y) = \frac{1}{3x^2} \frac{1}{y^2} - 1$$

Therefore, $\phi(y) = -y + c$

Therefore,

$$2x^{\frac{1}{2}} \left(\frac{3}{y^2 + 1} \right) - y + c = 0.$$

Q.8 Find the general solution of the differential equation $x^2y'' + xy' + 4y = 2x \ln x$ by method of undetermined coefficients. (6)

Ans:

Taking the transformation, $x = e^z$, we get

$$\frac{dy}{dz} = e^z \frac{dy}{dx} \quad \text{and} \quad \frac{d^2y}{dx^2} = \frac{1}{x^2} \left(\frac{d^2y}{dz^2} - \frac{dy}{dz} \right)$$

therefore,
$$\frac{d^2y}{dz^2} + 4z = 2ze^z \quad \text{-----(1)}$$

So the linearly independent solutions of the homogeneous equation are

$$\phi_1(z) = \cos 2z, \phi_2(z) = \sin 2z$$

The particular solution

By the method of undetermined coefficients, the particular solution is in the form

$$y(z) = c_1 e^z + c_2 z e^z$$

and
$$y'(z) = c_1 e^z + c_2 z e^z + c_2 e^z$$

$$= (c_1 + c_2) e^z + c_2 z e^z$$

$$y'' = (c_1 + c_2) e^z + c_2 e^z + c_2 z e^z$$

$$= (c_1 + 2c_2) e^z + c_2 z e^z$$

Substituting in the equation(1), we get

$$(5c_1 + 2c_2)e^z + 5c_2ze^z = 2ze^z$$

$$\therefore c_2 = \frac{2}{5} \quad \text{and} \quad c_1 = \frac{-4}{25} \quad \text{-----(2)}$$

Hence the general solution

$$y(x) = c_1 e^z + c_2 z e^z + c_3 \sin 2z + c_4 \cos 2z$$

where c_1, c_2 given by (2) and c_3, c_4 are arbitrary.

$$y = c_3 \sin 2z + c_4 \cos 2z - \frac{4}{25} e^z + \frac{2}{5} z e^z$$

$$y = c_3 \sin 2(\log x) + c_4 \cos 2(\log x) - \frac{4}{25} x + \frac{2}{5} (x \cdot \log x).$$

Q.9 Find the general solution of the differential equation $x^3 y''' - x^2 y'' + 2xy' - 2y = x^3$. (9)

Ans:

This is Cauchy's homogeneous linear equation.

Putting $x = e^t, \frac{xdx}{dx} = Dy, \quad x^2 \frac{d^2y}{dx^2} = D(D-1)y.$

Then given equation becomes $(D(D-1)(D-2) - D(D-1) + 2D - 2)y = e^{3t}$.
which is linear equation with constant coefficients.

A.E. is $D^3 - 4D^2 + 5D - 2 = 0.$

$\Rightarrow D = 1, 1, 2.$

\therefore C.F. = $(c_1 + c_2 t)e^t + c_3 e^{2t}.$

$$\text{P.I.} = \frac{1}{D^3 - 4D^2 + 5D - 2} e^{3t}.$$

$$= \frac{1}{4} e^{3t}.$$

Hence the general solution is

$$y(x) = c_1 x + c_2 x \ln x + c_3 x^2 + \frac{1}{4} x^3$$

Q.10 Show that the eigen values of a Hermitian matrix are real. (7)

Ans:

Let λ be an eigenvalue and x be the corresponding eigenvector of the matrix A .

We have $Ax = \lambda x$. Premultiplying by \bar{x}^T , we get

$$\bar{x}^T Ax = \lambda \bar{x}^T x \quad (\text{or}) \quad \lambda = \frac{\bar{x}^T Ax}{\bar{x}^T x}$$

$$\bar{x}^T$$

The denominator x is always real and positive. Therefore the behaviour of λ is determined by $\bar{x}^T Ax$.

For a Hermitian matrix A , $A^T = \bar{A}$.

Now, $(\bar{x}^T Ax) = x^T \bar{A} \bar{x} = x^T \bar{A} \bar{x} = (x^T A^T \bar{x})^T = \bar{x}^T Ax$

$\therefore \bar{x}^T Ax$ is real.

Hence $\lambda = \frac{\bar{x}^T Ax}{\bar{x}^T x}$ is real.

Q.11 Using Frobenius method, find two linearly independent solutions of the differential equation $2x(1+x)y'' + (1+x)y' - 3y = 0$. (10)

Ans:

The point $x = 0$ is a regular singular point of the equation.

Let $y(x) = \sum_{m=0}^{\infty} c_m x^{m+r}$, $c_0 \neq 0$.

Then, $y'(x) = \sum_{m=0}^{\infty} c_m (m+r) x^{m+r-1}$

$y''(x) = \sum_{m=0}^{\infty} c_m (m+r)(m+r-1) x^{m+r-2}$

$2x^2 y'' + xy' - 3y + 2xy'' + y' = 0$ implies

$\sum_{m=0}^{\infty} [2c_m (m+r)(m+r-1) + c_m (m+r) - 3c_m] x^{m+r}$

$\sum_{m=0}^{\infty} [2c_m (m+r)(m+r-1) + c_m (m+r)] x^{m+r-1} = 0 \dots (1)$

The lowest degree term is the term containing x^{r-1} .

Setting this coefficient to zero, we get

$2c_0 r(r-1) + c_0 r = 0$

$\Rightarrow c_0 [2r^2 - 2r + r] = 0$

$c_0 \neq 0 \Rightarrow 2r^2 - r = 0$

$\Rightarrow r(2r-1) = 0$

$\Rightarrow r = 0, 1/2$

(1) may be written as

$\sum_{m=0}^{\infty} x^{m+r} \{[(m+r)(2m+2r-1) - 3] c_m + [(m+r+1)(2m+2r+1)] c_{m+1}\} = 0$

\therefore For $m \geq 0$, we get

$$c_{m+1} = \frac{-[(m+r)(2m+2r-1)-3]}{(m+r+1)(2m+2r+1)} c_m.$$

when $r = 0$

$$c_{m+1} = \frac{-[m(2m-1)-3]}{(m+1)(2m+1)} c_m.$$

$$c_1 = \frac{3}{1} c_0$$

$$c_2 = \frac{-(1 \cdot 1 - 3)}{2 \cdot 3} c_1 = \frac{2}{2 \cdot 3} \cdot c_1 = c_0, \quad y_1(x) = c_0[1 + 3x + x^2 + \dots]$$

when $c_0 = 1$, we get $y_1(x) = [1 + 3x + x^2 + \dots]$

when $r = \frac{1}{2}$

$$c_{m+1} = \frac{-\left[\left(m + \frac{1}{2}\right)2m - 3\right]}{\left(m + \frac{3}{2}\right)(2m + 2)} c_m$$

$$c_1 = c_0, \quad c_2 = \frac{-[3-3]}{\frac{5}{2} \cdot 4} c_1 = 0$$

Therefore $c_3 = c_4 = c_5 = \dots = 0$

$$\begin{aligned} \text{Hence } y_2(x) &= c_0 x^{\frac{1}{2}} [1 + x] \\ &= x^{\frac{1}{2}} [1 + x], \text{ for } c_0 = 1. \end{aligned}$$

Q.12 Solve the following system of equations by matrix method: (6)

$$5x + 3y + 14z = 4$$

$$y + 2z = 1$$

$$2x + y + 6z = 2$$

$$x + y + 2z = 0$$

Ans:

$$[A | b] = \left[\begin{array}{ccc|c} 5 & 3 & 14 & 4 \\ 0 & 1 & 2 & 1 \\ 2 & 1 & 6 & 2 \\ 1 & 1 & 2 & 0 \end{array} \right]$$

$$R_1 \leftrightarrow R_4 \quad \left[\begin{array}{ccc|c} 1 & 1 & 2 & 0 \\ 0 & 1 & 2 & 1 \\ 2 & 1 & 6 & 2 \\ 5 & 3 & 14 & 4 \end{array} \right]$$

$$R_3 \rightarrow R_3 - 2R_1, \quad R_4 \rightarrow R_4 - 5R_1 \quad \left[\begin{array}{cccc} 1 & 1 & 2 & 0 \\ 0 & 1 & 2 & 1 \\ 0 & -1 & 2 & 2 \\ 0 & -2 & 4 & 4 \end{array} \right]$$

$$R_4 \rightarrow R_3 - \frac{1}{2}R_4 \quad \left[\begin{array}{cccc} 1 & 1 & 2 & 0 \\ 0 & 1 & 2 & 1 \\ 0 & -1 & 2 & 2 \\ 0 & 0 & 0 & 0 \end{array} \right]$$

$$R_3 \rightarrow R_3 + R_2 \quad \left[\begin{array}{cccc} 1 & 1 & 2 & 0 \\ 0 & 1 & 2 & 1 \\ 0 & 0 & 4 & 3 \\ 0 & 0 & 0 & 0 \end{array} \right]$$

Therefore $\text{rank}(A|b) = \text{rank}(A) = 3$

So System admits unique solution.

Now the resultant system is

$$4z = 3 \Rightarrow z = \frac{3}{4}$$

$$y + 2z = 1 \Rightarrow y = -\frac{1}{2}$$

$$x + y + 2z = 0 \Rightarrow x = -1.$$

Hence the solution is

$$x = -1, \quad y = -\frac{1}{2}, \quad z = \frac{3}{4}.$$

Q.13 Express the polynomial $7x^4 + 6x^3 + 3x^2 + x - 6$ in terms of Legendre polynomials.

(8)

Ans:

$$\text{we have } P_0 = 1, P_1(x) = x, P_2(x) = \frac{1}{2}(3x^2 - 1), P_3(x) = \frac{1}{2}(5x^2 - 3x),$$

$$P_4(x) = \frac{1}{8}(35x^4 - 30x^2 + 3).$$

writing various powers of x in terms of legendre polynomials.

$$1 = P_0(x), \quad x = P_1(x), \quad x^2 = \frac{1}{3}(2P_2 + 1) = \frac{1}{3}(2P_2 + P_0)$$

$$x^3 = \frac{1}{5}(2P_3 + 3x) = \frac{1}{5}(2P_3 + 3P_1)$$

$$\begin{aligned} x^4 &= \frac{1}{35}(8P_4 + 30x^2 - 3) \\ &= \frac{1}{35}(8P_4 + 10(2P_2 + P_0) - 3P_0) \\ &= \frac{1}{35}(8P_4 + 20P_2 + 7P_0) \end{aligned}$$

Now,

$$\begin{aligned} &7x^4 + 6x^3 + 3x^2 + x - 6 \\ &= \frac{7}{35}(8P_4 + 20P_2 + 7P_0) + \frac{6}{5}(2P_3 + 3P_1) = \frac{3}{5}(2P_2 + P_0) + P_1 - 6P_0 \\ &= \frac{8}{5}P_4 + \frac{12}{5}P_3 + 4P_2 + 2P_2 + \frac{18}{5}P_1 + P_1 + \frac{7}{5}P_0 + P_0 - 6P_0 \\ &= \frac{8}{5}P_4 + \frac{12}{5}P_3 + 6P_2 + \frac{23}{5}P_1 - \frac{18}{5}P_0 \end{aligned}$$

Q.14 Let J_α be the Bessel function of order α . Show $\left(\sqrt{\frac{\pi x}{2}}\right) J_{3/2}(x) = \frac{\sin x}{x} - \cos x$.

(8)

Ans:

$$\begin{aligned} &\frac{\sin x}{x} - \cos x \\ &= \frac{1}{x} \left(x - \frac{x^3}{3!} + \frac{x^5}{5!} - \dots \right) - \left(1 - \frac{x^2}{2!} + \frac{x^4}{4!} - \dots \right) \\ &= x^2 \left(\frac{1}{2!} - \frac{1}{3!} \right) - x^4 \left(\frac{1}{4!} - \frac{1}{5!} \right) + x^6 \left(\frac{1}{6!} - \frac{1}{7!} \right) - \dots \\ &= x^2 \times \frac{2}{6} - x^4 \times \frac{4}{5!} + \dots \\ &= \frac{x^2}{3} - \frac{x^4}{5 \cdot 3 \cdot 2} + \frac{x^6}{2 \cdot 3 \cdot 4 \cdot 5 \cdot 7} - \dots \end{aligned}$$

Now we know that

$$\begin{aligned}
 \sqrt{\frac{\pi x}{2}} J_{3/2}(x) &= \sqrt{\frac{\pi x}{2}} \sum_{r=0}^{\infty} \frac{(-1)^r \left(\frac{x}{2}\right)^{3/2+2r}}{r! \Gamma\left(1 + \frac{3}{2} + r\right)} \\
 &= \sqrt{\pi} \cdot \sum_{r=0}^{\infty} \frac{(-1)^r \left(\frac{x}{2}\right)^{\frac{3}{2} + \frac{1}{2} + 2r}}{\underbrace{r!}_{\left[\cdot \right]} \cdot r + \frac{5}{2}} \\
 &= \sqrt{\pi} \cdot \sum_{r=0}^{\infty} \frac{(-1)^r (x^2)^{r+1}}{2^{2r+2} \cdot \underbrace{r!}_{\left[\cdot \right]} \cdot r + \frac{5}{2}} \\
 &= \sqrt{\pi} \left[\frac{x^2}{2^2 \cdot \frac{5}{2}} - \frac{x^4}{2^4 \cdot \frac{7}{2}} + \frac{x^6}{2^6 \cdot \frac{9}{2}} - \dots \right] \\
 &= \frac{x^2}{3} - \frac{x^4}{2 \cdot 3 \cdot 5} + \frac{x^6}{2 \cdot 3 \cdot 4 \cdot 5 \cdot 7} - \dots \\
 &= \frac{\sin x}{x} - \cos x.
 \end{aligned}$$

Q.15 If A is a diagonalizable matrix and f (x) is a polynomial, then show that f(A) is also diagonalizable. (7)

Ans:

let $f(x) = x^n + a_1 x^{n-1} + \dots + a_n$

There exists a matrix P such that $P^{-1}AP = D$

Now, $f(A) = A^n + a_1 A^{n-1} + \dots + a_n$

$D^2 = P^{-1}AP \cdot P^{-1}AP = P^{-1}A^2P$

by induction, we may show that

$$D^k = P^{-1}A^kP \quad k = 1, 2, \dots, n$$

Therefore, $P^{-1}f(A)P = D^n + \dots + a_n = f(D)$

Since D is a diagonal matrix, f(D) is also diagonal.

Thus f(A) is diagonalizable.

Q.16. Let $A = \begin{pmatrix} 3 & 2 & 1 \\ 0 & 2 & 0 \\ 1 & 2 & 3 \end{pmatrix}$. Find the matrix P so that $P^{-1}AP$ is a diagonal matrix. (9)

Ans:

Eigen values are

$$\begin{vmatrix} 3-\lambda & 2 & 1 \\ 0 & 2-\lambda & 0 \\ 1 & 2 & 3-\lambda \end{vmatrix} = -\lambda^3 + 8\lambda^2 - 20\lambda + 16 = 0$$

Therefore $\lambda = 2, 2, 4$ are Eigen values .

Eigen values corresponding to $\lambda = 2$ is

$$\begin{pmatrix} 1 & 2 & 1 \\ 0 & 0 & 0 \\ 1 & 2 & 1 \end{pmatrix} \begin{pmatrix} x_1 \\ x_2 \\ x_3 \end{pmatrix} = \begin{pmatrix} 0 \\ 0 \\ 0 \end{pmatrix}$$

$$x_1 + 2x_2 + x_3 = 0$$

$$\therefore \begin{pmatrix} x_1 \\ x_2 \\ x_3 \end{pmatrix} = \begin{pmatrix} -2x_2 - x_3 \\ x_2 \\ x_3 \end{pmatrix} = x_2 \begin{pmatrix} -2 \\ 1 \\ 0 \end{pmatrix} + x_3 \begin{pmatrix} -1 \\ 0 \\ 1 \end{pmatrix}$$

The eigen vectors are $(-2 \ 1 \ 0)^T$ and $(-1 \ 0 \ 1)^T$

Eigen vector corresponding to $\lambda = 4$ is

$$\begin{pmatrix} -1 & 2 & 1 \\ 0 & -2 & 0 \\ 1 & 2 & -1 \end{pmatrix} \begin{pmatrix} x_1 \\ x_2 \\ x_3 \end{pmatrix} = \begin{pmatrix} 0 \\ 0 \\ 0 \end{pmatrix}$$

$$-x_1 + 2x_2 + x_3 = 0$$

$$-2x_2 = 0$$

$$x_1 + 2x_2 - x_3 = 0$$

$$x_2 = 0 \text{ and } x_1 = x_3$$

\therefore The eigen vector is $(1 \ 0 \ 1)^T$

The matrix $P = \begin{bmatrix} -2 & -1 & 1 \\ 1 & 0 & 0 \\ 0 & 1 & 1 \end{bmatrix}$

Q.17 Show that the function

$$f(x, y) = \begin{cases} \frac{x^2 + y^2}{|x| + |y|}, & (x, y) \neq (0, 0) \\ 0, & (x, y) = (0, 0) \end{cases}$$

is continuous at $(0, 0)$ but its partial derivatives f_x and f_y do not exist at $(0, 0)$.

(8)

Ans: We have

$$|f(x, y) - f(0, 0)| = \left| \frac{x^2 + y^2}{|x| + |y|} \right| \leq \frac{[|x| + |y|]^2}{|x| + |y|} < |x| + |y|$$

$$\leq 2\sqrt{x^2 + y^2} < \epsilon$$

Taking $\delta < \epsilon / 2$, we find that

$$|f(x, y) - 0| < \epsilon \text{ whenever } 0 < \sqrt{x^2 + y^2} < \delta$$

$$\text{Therefore } \lim_{(x, y) \rightarrow (0, 0)} f(x, y) = 0 = f(0, 0)$$

Hence the given function is continuous at $(0, 0)$

Now at $(0, 0)$, we have

$$\lim_{\Delta x \rightarrow 0} \frac{\Delta_x f}{\Delta x} = \lim_{\Delta x \rightarrow 0} \frac{f(\Delta x, 0) - f(0, 0)}{\Delta x} = \lim_{\Delta x \rightarrow 0} \frac{\Delta x}{|\Delta x|} = \begin{cases} 1, & \text{when } \Delta x > 0 \\ -1, & \text{when } \Delta x < 0 \end{cases}$$

Hence limit does not exist. Therefore f_x does not exist at $(0, 0)$.

Also at $(0, 0)$, the limit

$$\lim_{\Delta y \rightarrow 0} \frac{\Delta_y f}{\Delta y} = \lim_{\Delta y \rightarrow 0} \frac{f(0, \Delta y) - f(0, 0)}{\Delta y} = \lim_{\Delta y \rightarrow 0} \frac{\Delta y}{|\Delta y|} = \begin{cases} 1, & \text{when } \Delta y > 0 \\ -1, & \text{when } \Delta y < 0 \end{cases}$$

Hence limit does not exist at $(0, 0)$.

Q.18 Find the linear and the quadratic Taylor series polynomial approximation to the function $f(x, y) = 2x^3 + 3y^3 - 4x^2y$ about the point $(1, 2)$. Obtain the maximum absolute error in the region $|x - 1| < 0.01$ and $|y - 2| < 0.1$ for the two approximations. (8)

Ans:

$$f(x, y) = 2x^3 + 3y^3 - 4x^2y; \quad f(1, 2) = 18$$

$$f_x(x, y) = 6x^2 - 8xy; \quad f_x(1, 2) = -10$$

$$f_y(x, y) = 9y^2 - 4x^2; \quad f_y(1, 2) = 32$$

$$f_{xx}(x, y) = 12x - 8y; \quad f_{xx}(1, 2) = -4$$

$$f_{xy}(x, y) = -8x; \quad f_{xy}(1, 2) = -8$$

$$f_{yy}(x, y) = 18y; \quad f_{yy}(1, 2) = 36$$

$$f_{xxx}(x, y) = 12; \quad f_{xxy}(x, y) = -8$$

$$f_{xyy}(x, y) = 0; \quad f_{yyy}(x, y) = 18$$

The linear approximation is given by

$$f(x, y) = f(1,2) + [(x-1)f_x(1,2) + (y-2)f_y(1,2)]$$

$$= 18 + (x-1)(-10) + (y-2)(32)$$

Maximum absolute error in the linear approximation is given by

$$|R_1| \leq \frac{B}{2} [|x-1| + |y-2|]^2 \leq \frac{B}{2} [(0.01) + (0.1)]^2 = 0.00605B$$

where $B = \max [|f_{xx}|, |f_{xy}|, |f_{yy}|]$ in the given region

$$|x-1| < 0.01, \quad |y-2| < 0.1$$

$$\text{Now } \max |f_{xx}| = \max |12x - 8y| = \max |12(x-1) - 8(y-2) - 4|$$

$$\leq \max [12|x-1| - 8|y-2| + 4] = 4.92$$

$$\max |f_{xy}| = \max |-8x| = \max |8(x-1) + 8| \leq \max [8|x-1| + 8] = 8.08$$

$$\max |f_{yy}| = \max |18y| = \max [18(y-2) + 36] \leq 37.8$$

Hence $|B| = 37.8$ and $|R_1| \leq 0.23$

The quadratic approximation is given by

$$f(x, y) = f(1,2) + [(x-1)f_x(1,2) + (y-2)f_y(1,2)]$$

$$+ \frac{1}{2} [(x-1)^2 f_{xx}(1,2) + 2(x-1)(y-2)f_{xy}(1,2) + (y-2)^2 f_{yy}(1,2)].$$

$$= 18 - 10(x-1) + 32(y-2) - 2[(x-1)^2 + 4(x-1)(y-2) - 9(y-2)^2]$$

The maximum absolute error in the quadratic approximation is given by

$$|R_2| \leq \frac{B}{6} [|x-1| + |y-2|]^3 \leq \frac{B}{6} (0.11)^3$$

$$\text{where } B = \max [|f_{xxx}|, |f_{xxy}|, |f_{xyy}|, |f_{yyy}|]$$

$$= \max [12, 8, 0, 18] = 18$$

$$\therefore |R_2| \leq \frac{18}{6} (0.11)^3 = 0.004$$

Q.19 Find the shortest distance between the line $y = 10 - 2x$ and the ellipse $\frac{x^2}{4} + \frac{y^2}{9} = 1$. (8)

Ans:

Let (x, y) be a point on the ellipse and (u, v) be a point on the line and the ellipse is the square root of the minimum value of

$$f(x, y, u, v) = (x-u)^2 + (y-v)^2$$

Subject to the constraints

$$\phi_1(x, y) = \frac{x^2}{4} + \frac{y^2}{9} - 1 = 0, \quad \phi_2(u, v) = 2u + v - 10 = 0$$

$$\text{let } F(x, y, u, v, \lambda, \lambda_2) = (x - u)^2 + (y - v)^2 + \lambda_1 \left[\frac{x^2}{4} + \frac{y^2}{9} - 1 \right] + \lambda_2 [2u + v - 10]$$

$$\frac{\delta F}{\delta x} = 2(x - u) + \frac{x}{2} \lambda_1 = 0 \quad \text{or} \quad \lambda_1 x = 4(u - x)$$

$$\frac{\delta F}{\delta y} = 2(y - v) + \frac{2y}{9} \lambda_1 = 0 \quad \text{or} \quad \lambda_1 y = 9(v - y)$$

$$\frac{\delta F}{\delta u} = 2(x - u) + 2\lambda_2 = 0 \quad \text{or} \quad \lambda_2 = x - u$$

$$\frac{\delta F}{\delta v} = 2(y - v) + \lambda_2 = 0 \quad \text{or} \quad \lambda_2 = 2(y - v)$$

Eliminating λ_1, λ_2 we get

$$4(u - x)y = 9(v - y)x \quad \text{and} \quad x - u = 2(y - v)$$

Dividing we get $8y = 9x$. Substituting in ellipse we get

$$\frac{x^2}{4} + \frac{9x^2}{64} = 1 \quad \text{or} \quad x = \pm \frac{8}{5}, \quad y = \pm \frac{9}{5}$$

Corresponding to $x = \frac{8}{5}, y = \frac{9}{5}$, we get $u = 2v - 2$.

Substituting in the equation of line $2u + v - 10 = 0$, we get $u = \frac{18}{5}, v = \frac{14}{5}$

Hence an extremum is obtained when $(x, y) = \left(\frac{8}{5}, \frac{9}{5} \right)$
 The distance between the two points is $\sqrt{5}$.

Corresponding to $x = -\frac{8}{5}, y = -\frac{9}{5}$, we get $u = \frac{22}{5}, v = \frac{6}{5}$.

Hence another extremum is obtained

$$\text{when } (x, y) = \left(-\frac{8}{5}, -\frac{9}{5} \right) \text{ and } (u, v) = \left(\frac{22}{5}, \frac{6}{5} \right).$$

The distance between these two and pts is $3\sqrt{5}$.

Hence shortest distance between line and ellipse is $\sqrt{5}$.

Q.20 Evaluate the double integral $\iint_R xy \, dx \, dy$, where R is the region bounded by the x-axis, the line $y = 2x$ and the parabola $x^2 = 4ay$. (8)

Ans:

The points of intersection of the curves

$y = 2x$ and $y = \frac{x^2}{4a}$ are $(0, 0)$ and $(8a, 16a)$

The region $R = \left\{ (x, y); \left(\frac{x^2}{4a} \right) \leq y \leq 2x, 0 \leq x \leq 8a \right\}$

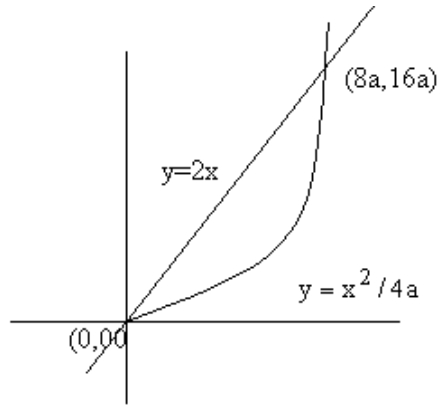

We evaluate the double integrate as

$$\begin{aligned}
 I &= \iint_R xy \, dx \, dy = \int_0^{8a} \left(\int_{x^2/4a}^{2x} xy \, dy \right) dx \\
 &= \int_0^{8a} \frac{xy^2}{2} \Big|_{x^2/4a}^{2x} dx = \int_0^{8a} \frac{x}{2} \left(4x^2 - \frac{x^4}{16a^2} \right) dx \\
 &= \frac{x^4}{2} - \frac{x^6}{192a^2} \Big|_0^{8a} = \frac{2048}{3} a^4.
 \end{aligned}$$

Q.21 Evaluate the integral $\iint_R (x - y)^2 \cos^2(x + y) \, dx \, dy$, where R is the parallelogram with successive vertices at $(\pi, 0)$, $(2\pi, \pi)$, $(\pi, 2\pi)$ and $(0, \pi)$. (8)

Ans:

The region R is given in figure

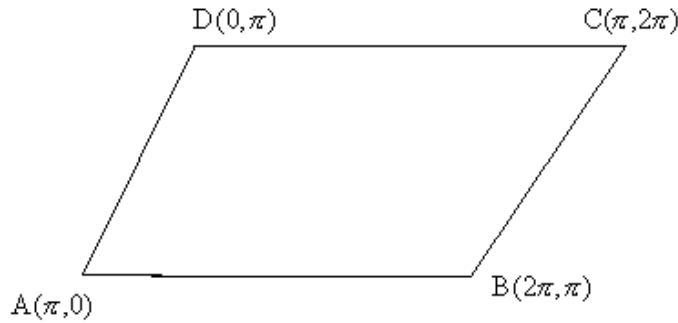

The equations of the sides AB, BC, CD and DA are respectively $x - y = \pi$, $x + y = 3\pi$, $x - y = -\pi$, $x + y = \pi$.

Let $y - x = u$, $y + x = v$. Then $-\pi \leq u \leq \pi$ and $\pi \leq v \leq 3\pi$

we obtain $x = \frac{v - u}{2}$, $y = \frac{v + u}{2}$

$$J = \frac{\delta(x, y)}{\delta(u, v)} = \begin{vmatrix} \delta x / \delta u & \delta x / \delta v \\ \delta y / \delta u & \delta y / \delta v \end{vmatrix} = \begin{vmatrix} -1/2 & 1/2 \\ 1/2 & 1/2 \end{vmatrix} = -\frac{1}{2}$$

$$|J| = \frac{1}{2}$$

$$\begin{aligned} \therefore I &= \iint_R (x - y)^2 \cos^2(x + y) dx dy \\ &= \frac{1}{2} \int_{-\pi}^{3\pi} \int_{-\pi}^{\pi} u^2 \cos^2 v du dv \\ &= \frac{1}{2} \int_{-\pi}^{\pi} u^2 du \int_{\pi}^{3\pi} \cos^2 v dv \\ &= \frac{\pi^4}{3} \end{aligned}$$

Q.22 Show that $J_0^2 + 2(J_1^2 + J_2^2 + \dots) = 1$, where $J_n(x)$ is the Bessel function of n^{th} order. (8)

Ans:

We know that

$$\frac{d}{dx} (J_n^2 + J_{n+1}^2) = 2J_n J_n^1 + 2J_{n+1} J_{n+1}^1$$

and $J_n^1(x) = \frac{n}{x} J_n - J_{n+1}$

$$J_{n+1}^1 = J_n - \frac{n+1}{x} J_{n+1}$$

$$\begin{aligned} \text{Thus } \left(J_n^2 + J_{n+1}^2 \right)' &= 2J_n \left(\frac{n}{x} J_n - J_{n+1} \right) + 2J_{n+1} \left(J_n - \frac{n+1}{x} J_{n+1} \right) \\ &= 2 \left[\frac{n}{x} J_n^2 - \frac{n+1}{x} J_{n+1}^2 \right] \end{aligned}$$

Substituting $n=0, 1, 2, \dots$ adding we get

$$\left(J_0^2 + 2(J_1^2 + J_2^2 + \dots) \right)' = 0$$

$$\text{Integrating } J_0^2 + 2(J_1^2 + J_2^2 + \dots) = C$$

let $x = 0$, since $J_0(0) = 1$ and $J_n(0) = 0, n > 0$. thus $c = 1$

$$\therefore J_0^2 + 2(J_1^2 + J_2^2 + \dots) = 1.$$

Q.23 Show that
$$\int_{-1}^1 (1-x^2) P_m'(x) P_n'(x) dx = \begin{cases} 0 & \text{if } m \neq n \\ \frac{2n(n+1)}{2n+1}, & \text{if } m = n \end{cases} \quad (6)$$

where $P_k(x)$ are the Legendre polynomials of order K .

Ans:

Integrating by parts

$$\begin{aligned} \int_{-1}^1 (1-x^2) P_m^1 P_n^1 dx &= \int_{-1}^1 \left((1-x^2) P_m^1 \right) P_n^1 dx \\ &= (1-x^2) P_m^1 P_n^1 \Big|_{-1}^1 - \int_{-1}^1 P_n \frac{d}{dx} \left((1-x^2) P_m^1 \right) dx \\ &= 0 - \int_{-1}^1 P_n \left[(1-x^2) P_m^{11} - 2x P_m^1 \right] dx. \end{aligned}$$

But $P_m(x)$ is the solution of Legendre's equation. Hence

$$(1-x^2) P_m'' - 2x P_m' + m(m+1) P_m = 0$$

$$\therefore \int_{-1}^1 (1-x^2) P_m' P_n' dx = (-1)^2 m(m+1) \int_{-1}^1 P_n P_m dx$$

Now by orthogonality property, we have

$$\therefore \int_{-1}^1 (1-x^2) P_m' P_n' dx = 0 \quad \text{if } m \neq n$$

$$\begin{aligned}
 \text{If } m = n \quad \int_{-1}^1 P_n^2(x) dx &= \frac{1}{(2^n \sqrt{n})^2} \int_{-1}^1 D^n(x^2 - 1)^n D^n(x^2 - 1)^n dx \\
 &= \frac{(-1)^n}{(2^n \sqrt{n})^2} \int_{-1}^1 |D^n(x^2 - 1)^n| dx \\
 &= \frac{2 \cdot |2n|^{\pi/2}}{(2^n \sqrt{n})^2} \int_0^{\pi/2} \cos^{2n+1} \theta d\theta \\
 &= \frac{2}{2n+1} \cdot \frac{(2^n \sqrt{n})^2}{(2^n \sqrt{n})^2} \\
 \therefore \int_{-1}^1 (1-x^2) P_m' P_n'(x) dx &= \frac{2n(n+1)}{2n+1}, \quad m = n.
 \end{aligned}$$

Q.24 Find the power series solution about $x = 2$, of the initial value problem $4y'' - 4y' + y = 0, y(2) = 0, y'(2) = \frac{1}{e}$. Express the solution in closed form. (10)

Ans:

We have

$$y(x) = y(2) + (x - 2)y'(2) + \frac{(x - 2)^2}{2} y''(2) + \dots$$

From the given equation, we have $y'' = \frac{1}{4}[4y' - y]$

Differentiating $(m - 2)$ times we get $y^{(m)} = \frac{1}{4}[4y^{(m-1)} - y^{(m-2)}]$

Putting $x = 2$, we get

$$y^{(m)}(2) = \frac{1}{4}[4y^{(m-1)}(2) - y^{(m-2)}(2)], \quad m = 2, 3, \dots$$

using the value $y(2) = 0$ and $y'(2) = \frac{1}{e}$, we get

$$y''(2) = \frac{1}{4} \left[\frac{4}{e} - 0 \right] = \frac{1}{e}$$

$$y'''(2) = \frac{1}{4} [4y''(2) - y'(2)] = \frac{1}{4} \left[\frac{4}{e} - \frac{1}{e} \right] = \frac{3}{4e}$$

$$\begin{aligned}
 \text{Thus } y(x) &= (x-2)\frac{1}{e} + \frac{(x-2)^2}{\underline{2}}\left(\frac{1}{e}\right) + \frac{(x-2)^3}{\underline{3}}\left(\frac{3}{4e}\right) + \dots \\
 &= \frac{x-2}{e} \left[1 + \frac{x-2}{2} + \frac{((x-2)/2)^2}{\underline{2}} + \dots \right] \\
 &= \frac{1}{e}(x-2)e^{x-2/2}. \\
 &= \frac{x-2}{e} \cdot e^{\left(\frac{x-2}{2}\right)}
 \end{aligned}$$

Q.25 Solve the initial value problem $y''' - 6y'' + 11y' - 6y = 0$ $y(0) = 0$, $y'(0) = 1$, $y''(0) = -1$. (8)

Ans:

A.E. is

$$m^3 - 6m^2 + 11m - 6 = 0$$

$$m = 1, 2, 3.$$

$$y = c_1e^x + c_2e^{2x} + c_3e^{3x}.$$

$$y(0) = 0$$

$$\Rightarrow c_1 + c_2 + c_3 = 0$$

$$y'(0) = 1$$

$$\Rightarrow c_1 + 2c_2 + 3c_3 = 1$$

$$y''(0) = -1$$

$$\Rightarrow c_1 + 4c_2 + 9c_3 = -1.$$

$$\text{Thus } \begin{bmatrix} 1 & 1 & 1 \\ 1 & 2 & 3 \\ 1 & 4 & 9 \end{bmatrix} \begin{bmatrix} c_1 \\ c_2 \\ c_3 \end{bmatrix} = \begin{pmatrix} 0 \\ 1 \\ -1 \end{pmatrix}$$

$$\sim \begin{bmatrix} 1 & 1 & 1 \\ 0 & 1 & 2 \\ 0 & 0 & 2 \end{bmatrix} \begin{pmatrix} c_1 \\ c_2 \\ c_3 \end{pmatrix} = \begin{pmatrix} 0 \\ 1 \\ -4 \end{pmatrix}$$

$$\text{Solving } c_1 = -3, c_2 = 5, c_3 = -2.$$

$$\text{Thus solution of initial value problem is } y = -3e^x + 5e^{2x} - 2e^{3x}.$$

Q.26 Solve $x^2 \frac{d^2y}{dx^2} + x \frac{dy}{dx} - y = \frac{x^3}{1+x^2}$. (8)

Ans:

$$\text{Let } x = e^t.$$

$$(D(D - 1) + D - 1)y = \frac{e^{3t}}{1 + e^{2t}}.$$

A.E. $m^2 - 1 = 0.$
 $m = \pm 1.$

C.F. $c_1x + \frac{c_2}{x}.$

$$\begin{aligned} \text{P.I.} &= \frac{1}{D^2 - 1} \left[\frac{e^{3t}}{1 + e^{2t}} \right] \\ &= \frac{1}{2} \left[\frac{1}{D - 1} - \frac{1}{D + 1} \right] \frac{e^{3t}}{1 + e^{2t}} \\ &= \frac{1}{2} \left[e^t \int \frac{e^{2t} dt}{1 + e^{2t}} - e^{-t} \int \frac{e^{4t}}{1 + e^{2t}} dt \right] \\ &= \frac{1}{4} (e^t + e^{-t}) \log(1 + e^{2t}) - \frac{e^{-t}}{4} (1 + e^{2t}) \\ &= \frac{1}{4} \left(x + \frac{1}{x} \right) \log(1 + x^2) - \frac{1}{4x} (1 + x^2) \\ \therefore y &= c_1x + \frac{c_2}{x} + \frac{1}{4x} (x^2 + 1) \left[\log(1 + x^2) - 1 \right]. \end{aligned}$$

Q.27 Show that set of functions $\left\{ x, \frac{1}{x} \right\}$ forms a basis of the differential equation $x^2y'' + xy' - y = 0$. Obtain a particular solution when $y(1) = 1, y'(1) = 2$. (6)

Ans:

Since $y_1(x) = x, y_1' = 1, y_1'' = 0$ and

$$x^2y_1'' + xy_1' - y_1 = 0. \text{ and}$$

$$y_2(x) = \frac{1}{x}, y_2' = -\frac{1}{x^2}, y_2'' = \frac{2}{x^3}.$$

$$x^2y_2'' + xy_2' - y_2 = 0.$$

Hence $y_1(x)$ and $y_2(x)$ are solutions of the given equation.

The Wronskian is given by

$$W(y_1, y_2) = \begin{vmatrix} x & \frac{1}{x} \\ 1 & -\frac{1}{x^2} \end{vmatrix} = -\frac{2}{x} \neq 0 \text{ for } x \geq 1.$$

Thus the set $\{y_1(x), y_2(x)\}$ forms a basis of the equation.

The general solution is

$$y(x) = C_1 y_1(x) + C_2 y_2(x) = C_1 x + \frac{C_2}{x}.$$

$$y(1) = 1 = C_1 + C_2$$

$$y_1(1) = 2 = C_1 - C_2$$

$$\text{so, we get } C_1 = \frac{3}{2}, C_2 = -\frac{1}{2}$$

$$\therefore y = \frac{1}{2} \left(3x - \frac{1}{x} \right).$$

Q.28 Solve the following differential equations:

(2×5 = 10)

(i) $(2xy + x^2)y' = 3y^2 + 2xy$

(ii) $(6x - 4y + 1)dy - (3x - 2y + 1)dx = 0$

Ans:

(i) Equation is $(3y^2 + 2xy)dx - (2xy + x^2)dy = 0$,

$$M = 3y^2 + 2xy,$$

$$N = -2xy - x^2.$$

$$\frac{\partial M}{\partial y} = 6y + 2x$$

$$\frac{\partial N}{\partial x} = -2y - 2x$$

$$\therefore \frac{\partial M}{\partial y} \neq \frac{\partial N}{\partial x}.$$

Thus, the equation is not exact and M, N are homogenous function of degree 2,

Hence $\frac{1}{Mx + Ny} = \frac{1}{xy(x+y)}$ is an I.F.

Thus equation is

$$\frac{3y+2x}{x(x+y)}dx - \frac{2y+x}{y(x+y)}dy = 0$$

$$\frac{\partial M}{\partial y} = \frac{1}{(x+y)^2}, \quad \frac{\partial N}{\partial x} = \frac{1}{(x+y)^2}.$$

Now $M_1 = \frac{3y+2x}{x(x+y)}, \quad N_1 = -\frac{2y+x}{y(x+y)}.$

∴ Solution is

$$\int \left(\frac{3}{x} - \frac{1}{x+y} \right) dx + \int \frac{-1}{y} dy = C.$$

$$\Rightarrow 3 \ln x - \ln |x+y| - \ln |y| = \ln C.$$

$$\Rightarrow x^3 = Cy(x+y)$$

(ii)

$$\frac{dy}{dx} = \frac{3x-2y+1}{2(3x-2y)+1}$$

let $3x-2y = t$, so that $3-2 \frac{dy}{dx} = \frac{dt}{dx}$.

$$\therefore \frac{dt}{dx} = 3 - \frac{2(t+1)}{2t+1} = \frac{4t+1}{2t+1}$$

Integrating, we get

$$\frac{1}{2} \int dt + \frac{1}{2} \int \frac{1}{4t+1} dt = x + C$$

$$\Rightarrow t + \frac{1}{4} \log 4 + \frac{1}{4} \log \left(t + \frac{1}{4} \right) = 2x + 2C \text{ or } 4x - 8y + \log(12x - 8y + 1) = C.$$

$$\Rightarrow 4x - 8y + \log \left(3x - 2y + \frac{1}{4} \right) = C.$$

Q.29 Let $T: \mathbb{R}^3 \rightarrow \mathbb{R}^2$ be a linear transformation defined by $T \begin{bmatrix} x \\ y \\ z \end{bmatrix} = \begin{bmatrix} y+z \\ y-z \end{bmatrix}$. Taking

$\left\{ \begin{pmatrix} 1 \\ 1 \\ 0 \end{pmatrix}, \begin{pmatrix} 0 \\ 1 \\ 1 \end{pmatrix}, \begin{pmatrix} 1 \\ 0 \\ 1 \end{pmatrix} \right\}$ as a basis in \mathbb{R}^3 , determine the matrix of linear transformation.

(8)

Ans:

The given matrix which maps the elements in \mathbb{R}^3 into \mathbb{R}^2 is a 2×3 matrix.

let the matrix is $A = \begin{bmatrix} a_1 & a_2 & a_3 \\ b_1 & b_2 & b_3 \end{bmatrix}$

$$T \begin{pmatrix} 0 \\ 1 \\ 1 \end{pmatrix} = \begin{pmatrix} 2 \\ 0 \end{pmatrix}, \quad T \begin{pmatrix} 1 \\ 0 \\ 1 \end{pmatrix} = \begin{pmatrix} 1 \\ -1 \end{pmatrix}, \quad T \begin{pmatrix} 1 \\ 1 \\ 0 \end{pmatrix} = \begin{pmatrix} 1 \\ 1 \end{pmatrix}$$

Therefore $\begin{bmatrix} a_1 & a_2 & a_3 \\ b_1 & b_2 & b_3 \end{bmatrix} \begin{pmatrix} 0 \\ 1 \\ 1 \end{pmatrix} = \begin{pmatrix} 2 \\ 0 \end{pmatrix}$ or $\begin{matrix} a_2 + a_3 = 2 \\ b_2 + b_3 = 0 \end{matrix}$

$$\begin{bmatrix} a_1 & a_2 & a_3 \\ b_1 & b_2 & b_3 \end{bmatrix} \begin{pmatrix} 1 \\ 0 \\ 1 \end{pmatrix} = \begin{pmatrix} 1 \\ -1 \end{pmatrix} \quad \text{or} \quad \begin{aligned} a_1 + a_3 &= 1 \\ b_1 + b_3 &= -1 \end{aligned}$$

$$\begin{bmatrix} a_1 & a_2 & a_3 \\ b_1 & b_2 & b_3 \end{bmatrix} \begin{pmatrix} 1 \\ 1 \\ 0 \end{pmatrix} = \begin{pmatrix} 1 \\ 1 \end{pmatrix} \quad \text{or} \quad \begin{aligned} a_1 + a_2 &= 1 \\ b_1 + b_2 &= 1 \end{aligned}$$

Solving these equations, we obtain the matrix $A = \begin{bmatrix} 0 & 1 & 1 \\ 0 & 1 & -1 \end{bmatrix}$

Q.30 If $A = \begin{bmatrix} 1 & 0 & 0 \\ 1 & 0 & 1 \\ 0 & 1 & 0 \end{bmatrix}$ then show that $A^n = A^{n-2} + A^2 - I$, for $n \geq 3$. Hence find A^{50} .

(8)

Ans:

The characteristic equation of A is given by

$$|A - \lambda I| = \begin{vmatrix} 1-\lambda & 0 & 0 \\ 1 & -\lambda & 1 \\ 0 & 1 & -\lambda \end{vmatrix} = 0$$

$$\Rightarrow \lambda^3 - \lambda^2 - \lambda + 1 = 0$$

Using Cayley Hamilton theorem, we get

$$A^3 - A^2 - A + I = 0.$$

$$\Rightarrow A^3 - A^2 = A - I.$$

$$\Rightarrow A^n - A^{n-1} = A^{n-2} - A^{n-3}.$$

Adding we get

$$A^n - A^2 = A^{n-2} - I$$

$$\text{or } A^n = A^{n-2} + A^2 - I, \quad n \geq 3.$$

Thus $A^n = (A^{n-4} + A^2 - I) + A^2 - I$

$$= A^{n-4} + 2(A^2 - I)$$

$$= \dots\dots\dots$$

$$= A^{n-(n-2)} + \frac{1}{2}(n-2)(A^2 - I)$$

$$= \frac{n}{2}A^2 - \frac{1}{2}(n-2)I.$$

$$\begin{aligned} \text{Thus } A^{50} &= 25A^2 - 24I \\ &= 25 \begin{bmatrix} 1 & 0 & 0 \\ 1 & 1 & 0 \\ 0 & 0 & 1 \end{bmatrix} - 24 \begin{bmatrix} 1 & 0 & 0 \\ 0 & 1 & 0 \\ 0 & 0 & 1 \end{bmatrix} = \begin{bmatrix} 1 & 0 & 0 \\ 25 & 1 & 0 \\ 25 & 0 & 1 \end{bmatrix} \end{aligned}$$

Q.31 Examine whether matrix A is similar to matrix B, where $A = \begin{bmatrix} 5 & 5 \\ -2 & 0 \end{bmatrix}$, $B = \begin{bmatrix} 1 & 2 \\ -3 & 4 \end{bmatrix}$. (8)

Ans:

The given matrices are similar if there exists an inevitable matrix P such that

$$A = P^{-1}BP \quad \text{or} \quad PA = BP$$

let $P = \begin{bmatrix} a & b \\ c & d \end{bmatrix}$ we shall determine a, b, c, d such that

$PA = BP$ and then check whether P is non-singular.

$$\begin{bmatrix} a & b \\ c & d \end{bmatrix} \begin{bmatrix} 5 & 5 \\ -2 & 0 \end{bmatrix} = \begin{bmatrix} 1 & 2 \\ -3 & 4 \end{bmatrix} \begin{bmatrix} a & b \\ c & d \end{bmatrix}$$

$$\text{or } 5a - 2b = a + 2c$$

$$5a = b + 2d$$

$$5c - 2d = -3a + 4c$$

$$5c = -3b + 4d.$$

$$\text{or } 4a - 2b - 2c = 0$$

$$5a - b - 2d = 0$$

$$3a + c - 2d = 0$$

$$3b + 5c - 4d = 0.$$

Solving, we get $a = 1, b = 1, c = 1, d = 2$

Thus $P = \begin{bmatrix} 1 & 1 \\ 1 & 2 \end{bmatrix}$ which is a non-singular matrix. Hence the matrices A and B are similar.

Q.32 Discuss the consistency of the following system of equations for various values of λ :

$$2x_1 - 3x_2 + 6x_3 - 5x_4 = 3$$

$$x_2 - 4x_3 + x_4 = 1$$

$$4x_1 - 5x_2 + 8x_3 - 9x_4 = \lambda$$

and if consistent, solve it. (8)

Ans:

The augmented matrix is

$$[A : B] = \begin{bmatrix} 2 & -3 & 6 & -5 & : & 3 \\ 0 & 1 & -4 & 1 & : & 1 \\ 4 & -5 & 8 & -9 & : & \lambda \end{bmatrix}$$

on operating $R_3 \rightarrow R_3 - 2R_1 \sim \begin{bmatrix} 2 & -3 & 6 & -5 & : & 3 \\ 0 & 1 & -4 & 1 & : & 1 \\ 0 & 1 & -4 & 1 & : & \lambda - 6 \end{bmatrix}$

$$\sim \begin{bmatrix} 2 & -3 & 6 & -5 & : & 3 \\ 0 & 1 & -4 & 1 & : & 1 \\ 0 & 0 & 0 & 0 & : & \lambda - 7 \end{bmatrix} R_3 \rightarrow R_3 - R_2$$

Now when $\lambda \neq 7$.

$\text{rank}(A:B) = 3$ and $\text{rank}(A) = 2$, hence the system is inconsistent.

When $\lambda = 7$, $\text{rank}(A:B) = 2 = \text{rank}(A)$, hence consistent.

Thus $x_2 - 4x_3 + x_4 = 1$

$$2x_1 - 3x_2 + 6x_3 - 5x_4 = 3.$$

let $x_3 = t_1, \quad x_4 = t_2.$

then $x_2 = 4t_1 - t_2 + 1$

$$x_1 = 3t_1 - t_2 + 3$$

Q.33 Show that for the function $f(x, y) = \sqrt{|xy|}$, partial derivatives f_x and f_y both exist at the origin and have value 0. Also show that these two partial derivatives are continuous except at the origin. (8)

Ans:

Now at $(0, 0)$,

$$f_x(0,0) = \lim_{h \rightarrow 0} \frac{f(h,0) - f(0,0)}{h} = \lim_{h \rightarrow 0} \frac{0}{h} = 0$$

$$f_y(0,0) = \lim_{k \rightarrow 0} \frac{f(0,k) - f(0,0)}{k} = \lim_{k \rightarrow 0} \frac{0}{k} = 0$$

If the function is differentiable at $(0, 0)$, then by definition $f(h, k) - f(0,0) = 0 \cdot h + 0 \cdot k + h \cdot \phi + k \cdot \psi$, where ϕ and ψ are functions of k and h and tend to zero as $(h, k) \rightarrow (0, 0)$. Putting $h = r \cos\theta, k = r \sin\theta$ and dividing by r , we get $|\cos\theta \sin\theta|^{1/2} = \phi \cos\theta + \psi \sin\theta$. Now for arbitrary $\theta, r \rightarrow 0$, implies that $(h, k) \rightarrow (0, 0)$.

Taking the limit as $r \rightarrow 0$, we get $|\cos\theta \sin\theta|^{1/2} = 0$, which is impossible for all arbitrary θ . Hence the function is not differentiable at $(0, 0)$ and consequently the partial derivatives f_x, f_y cannot be continuous at $(0, 0)$. For $(x, y) \neq (0, 0)$.

$$f_x(x, y) = \lim_{h \rightarrow 0} \frac{f(x+h, y) - f(x, y)}{h} = \lim_{h \rightarrow 0} \frac{\sqrt{|x+h||y|} - \sqrt{|x||y|}}{h}$$

$$= \lim_{h \rightarrow 0} \sqrt{|y|} \frac{|x+h| - |x|}{h[\sqrt{|x+h|} + \sqrt{|x|}]}$$

Now as $h \rightarrow 0$, we can take $x+h > 0$, i.e. $|x+h| = x+h$, when $x > 0$ and $x+h < 0$ or $|x+h| = -(x+h)$, when $x < 0$.

$$\therefore f_x(x, y) = \left\{ \begin{array}{l} \frac{1}{2} \sqrt{\frac{|y|}{|x|}}, \text{ when } x > 0 \\ -\frac{1}{2} \sqrt{\frac{y}{x}}, \text{ when } x < 0 \end{array} \right\}$$

Similarly,

$$\therefore f_y(x, y) = \left\{ \begin{array}{l} \frac{1}{2} \sqrt{\frac{|x|}{|y|}}, \text{ when } y > 0 \\ -\frac{1}{2} \sqrt{\frac{x}{y}}, \text{ when } y < 0 \end{array} \right\}$$

which is not continuous at the origin.

Q.34 In a plane triangle ABC, if the sides a, b be kept constant, show that the variations of its angles are given by the relation

$$\frac{dA}{\sqrt{a^2 - b^2 \sin^2 A}} = \frac{dB}{\sqrt{b^2 - a^2 \sin^2 B}} = -\frac{dC}{C} \tag{8}$$

Ans:

By the sine formula we have $\frac{a}{\sin A} = \frac{b}{\sin B}$ or $a \sin B = b \sin A$

Taking differentials on both sides, we get $a \cos B dB = b \cos A dA$.

$$\Rightarrow \frac{dA}{a \cos B} = \frac{dB}{b \cos A} = \frac{dA + dB}{a \cos B + b \cos A} \tag{1}$$

$$a \cos B = a\sqrt{1 - \sin^2 B} = \sqrt{a^2 - a^2 \sin^2 B} = \sqrt{a^2 - b^2 \sin^2 A}$$

$$b \cos A = b\sqrt{1 - \sin^2 A} = \sqrt{b^2 - b^2 \sin^2 A} = \sqrt{b^2 - a^2 \sin^2 B}$$

Also, by the projection rule in triangle ABC we have $a \cos B + b \cos A = c$, and

$A + B + C = \pi$, we have $dA + dB + dC = 0$ or $dA + dB = -dC$. Therefore, equation (1),

becomes

$$\frac{dA}{\sqrt{a^2 - b^2 \sin^2 A}} = \frac{dB}{\sqrt{b^2 - a^2 \sin^2 B}} = -\frac{dC}{c}$$

Q.35 Find the shortest distance from (0, 0) to hyperbola $x^2 + 7y^2 + 8xy = 225$ in XY plane. (8)

Ans:

We have to find the minimum value of $x^2 + y^2$ (the square of the distance from the origin to any point in the xy plane) subject to the constraint $x^2 + 8xy + 7y^2 = 225$.

Consider the function $F(x, y) = x^2 + y^2 + \lambda (x^2 + 8xy + 7y^2 - 225)$, where x, y are independent variables and λ is a constant.

Thus $dF = (2x + 2x\lambda + 8y\lambda) dx + (2y + 8x\lambda + 14y\lambda) dy$

Therefore, $(1+\lambda)x + 4\lambda y = 0$ and, $4\lambda x + (1 + 7\lambda)y = 0$.

Thus $\lambda = 1, -1/9$. For, $\lambda = 1, x = -2y$, and substitution in $x^2 + 8xy + 7y^2 = 225$, gives $y^2 = -45$, for which no real solution exists.

For $\lambda = -1/9, y = 2x$, and substitution in $x^2 + 8xy + 7y^2 = 225$, gives $x^2 = 5, y^2 = 20$ and so $x^2 + y^2 = 25$.

$$\begin{aligned} d^2F &= 2(1 + \lambda) dx^2 + 16\lambda dx dy + 2(1 + 7\lambda) dy^2 = \frac{16}{9} dx^2 - \frac{16}{9} dx dy + \frac{4}{9} dy^2 \\ &= \frac{4}{9} (2dx - dy)^2 > 0, \end{aligned}$$

and cannot vanish because $(dx, dy) \neq (0,0)$. Hence the function $x^2 + y^2$ has a minimum value 25.

Q.36 Express $\int_0^a \int_0^x x dx dy + \int_{\frac{a}{\sqrt{2}}}^a \int_0^{\sqrt{a^2 - x^2}} x dx dy$, as a single integral and then evaluate it. (8)

Ans:

$$\text{Let } I_1 = \int_0^a \int_0^x x dy dx \quad \text{and} \quad I_2 = \int_{\frac{a}{\sqrt{2}}}^a \int_0^{\sqrt{a^2 - x^2}} x dy dx$$

Let R_1 and R_2 be the regions over which I_1 and I_2 are being integrated respectively and are depicted by the shaded portion in fig. I.

As it is clear from Fig.II, $R = R_1 + R_2$

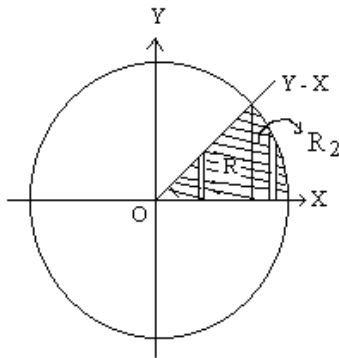

Fig. I

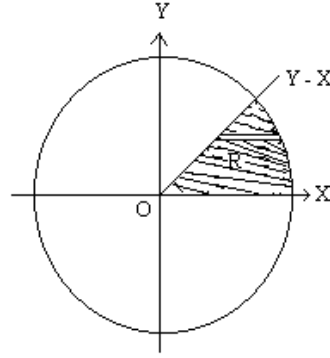

Fig. II

Thus, $I = I_1 + I_2 = \iint_R x dx dy$. For evaluating I we change the order of integration hence the elementary strip has to be taken parallel to x-axis from $y = x$ to $y = \sqrt{a^2 - x^2}$ i.e. the circle $x^2 + y^2 = a^2$.

$$\begin{aligned} \therefore I &= \int_0^{\frac{a}{\sqrt{2}}} \int_y^{\sqrt{a^2 - y^2}} x dx dy = \int_0^{\frac{a}{\sqrt{2}}} \left(\int_y^{\sqrt{a^2 - y^2}} x dx \right) dy = \int_0^{\frac{a}{\sqrt{2}}} \left(\frac{x^2}{2} \right)_y^{\sqrt{a^2 - y^2}} dy \\ &= \frac{1}{2} \int_0^{\frac{a}{\sqrt{2}}} (a^2 - y^2 - y^2) dy = \frac{1}{2} \left[a^2 y - \frac{2y^3}{3} \right]_0^{\frac{a}{\sqrt{2}}} = \frac{1}{2} \left[\frac{a^3}{\sqrt{2}} - \frac{2}{3} \frac{a^3}{2\sqrt{2}} \right] = \frac{a^3}{3\sqrt{2}} \end{aligned}$$

Q.37 Obtain the volume bounded by the surface $z = C \left(1 - \frac{x}{a}\right) \left(1 - \frac{y}{b}\right)$ and a quadrant of the elliptic cylinder $\frac{x^2}{a^2} + \frac{y^2}{b^2} = 1, z > 0$ and where $a, b > 0$ (8)

Ans:

In solid geometry $\frac{x^2}{a^2} + \frac{y^2}{b^2} = 1$ represents a cylinder whose axis is along z-axis and guiding curve ellipse. Required volume is given by

$$V = \iint_C z dx dy = \iint_C \left(1 - \frac{x}{a}\right) \left(1 - \frac{y}{b}\right) dx dy \text{ where } C: \frac{x^2}{a^2} + \frac{y^2}{b^2} = 1$$

Let us use elliptic polar co-ordinates $x = a r \cos\theta, y = b r \sin\theta$, where $0 \leq r \leq 1$,

$dx dy = ab r dr d\theta$, and $\frac{x^2}{a^2} + \frac{y^2}{b^2} = r^2$, hence

$$\begin{aligned}
 V &= abc \int_0^{\frac{\pi}{2}} \int_0^1 (1-r \cos \theta)(1-r \sin \theta)r dr d\theta \\
 &= abc \int_0^{\frac{\pi}{2}} \int_0^1 [r - r^2(\cos \theta + \sin \theta) + r^3 \cos \theta \sin \theta] dr d\theta \\
 &= abc \int_0^{\frac{\pi}{2}} \left[\frac{r^2}{2} - \frac{r^3(\cos \theta + \sin \theta)}{3} + \frac{r^4}{4} \cos \theta \sin \theta \right]_0^1 d\theta \\
 &= abc \int_0^{\frac{\pi}{2}} \left[\frac{1}{2} - \frac{(\cos \theta + \sin \theta)}{3} + \frac{1}{4} \cos \theta \sin \theta \right] d\theta \\
 &= abc \left[\frac{\theta}{2} - \frac{1}{3} \sin \theta + \frac{1}{3} \cos \theta + \frac{1}{8} \sin^2 \theta \right]_0^{\frac{\pi}{2}} \\
 &= abc \left[\frac{\pi}{4} - \frac{1}{3} + \frac{1}{8} - \frac{1}{3} \right] = abc \left[\frac{\pi}{4} - \frac{13}{24} \right].
 \end{aligned}$$

Q.38 Solve the following differential equations: (8)

- (i) $\sec x \frac{dy}{dx} = y + \sin x$
- (ii) $\left(\frac{y}{x} \sec y - \tan y \right) dx + (\sec y \log x - x) dy = 0$

Ans:

(i) The given equation can be written as

$$\frac{dy}{dx} - y \cos x = \sin x \cos x \quad (1)$$

It is linear in y, and here P = -cos x and Q = sin x cos x.

Then I.F. = $e^{\int P dx} = e^{\int -\cos x dx} = e^{-\sin x}$. Hence the solution of (1) is

$$Y(\text{I.F.}) = \int Q(\text{I.F.}) dx \text{ or } ye^{-\sin x} = \int e^{-\sin x} \sin x \cos x dx$$

Now, putting $-\sin x = t$, we get

$$ye^{-\sin x} = \int e^t dt = t e^t - \int e^t dt = (t-1)e^t + c = -(1 + \sin x)e^{-\sin x} + c$$

Therefore, the solution is $y = -(1 + \sin x) + ce^{\sin x}$
 $\Rightarrow y + 1 + \sin x = ce^{\sin x}$

This is the required solution where c is an arbitrary constant.

(ii)

The given equation is of the form $M dx + N dy = 0$ where

$$M = \frac{y}{x} \sec y - \tan y \quad \text{and} \quad N = \sec y \log x - x.$$

$$\therefore \frac{\partial M}{\partial y} = \frac{1}{x} \sec y + \frac{y}{x} \sec y \tan y - \sec^2 y, \quad \frac{\partial N}{\partial x} = \frac{1}{x} \sec y - 1,$$

$$\text{Now, } \frac{\frac{\partial N}{\partial x} - \frac{\partial M}{\partial y}}{M} = \frac{-1 - \frac{y}{x} \sec y \tan y + \sec^2 y}{\frac{y}{x} \sec y - \tan y} = -\tan y$$

$$\therefore I.F. = e^{\int -\tan y dy} = e^{\log \cos y} = \cos y$$

Multiplying the given equation throughout by $\cos y$, we get

$$\left(\frac{y}{x} - \sin y\right) dx + (\log x - x \cos y) dy = 0, \text{ which is exact.}$$

Therefore, the solution is

$$\int \left(\frac{y}{x} - \sin y\right) dx + \int 0 dy = c, \text{ or } y \log x - x \sin y = c$$

This is the required solution where c is an arbitrary constant.

Q.39 Solve the following differential equation by the method of variation of parameters.

$$x^2 \frac{d^2 y}{dx^2} + x \frac{dy}{dx} - y = x^2 e^x \tag{9}$$

Ans:

First of all we find the solution of the equation $x^2 \frac{d^2 y}{dx^2} + x \frac{dy}{dx} - y = 0$.

This is a homogeneous equation. Putting $x = e^z$ and $D = \frac{d}{dz}$, the equation reduces to

$$[D(D-1)+D-1] y = 0, \text{ which gives } D = 1, -1.$$

Therefore, $y = c_1e^z + c_2e^{-z} = c_1x + \frac{c_2}{x}$,

Therefore, $y = c_1e^z + c_2e^{-z} = c_1x + \frac{c_2}{x}$,

Writing the given equation in standard form, we get

$$\frac{d^2y}{dx^2} + \frac{1}{x} \frac{dy}{dx} - \frac{1}{x^2}y = e^x \quad (1)$$

Let $y = Ax + B/x$ be a solution of equation (1), where A, B are functions of x. Then

$$\frac{dy}{dx} = A - \frac{B}{x^2} + A_1x + \frac{B_1}{x}, \text{ Choose A and B such that } A_1x + \frac{B_1}{x} = 0 \quad (2)$$

Therefore, $\frac{dy}{dx} = A - \frac{B}{x^2}$ and $\frac{d^2y}{dx^2} = A_1 + \frac{2B}{x^3} - \frac{B_1}{x^2}$,

Substituting the values of y, $\frac{dy}{dx}$ and $\frac{d^2y}{dx^2}$ in equation(1), we get

$$\left(A_1 + \frac{2B}{x^3} - \frac{B_1}{x^2} \right) + \frac{1}{x} \left(A - \frac{B}{x^2} \right) - \frac{1}{x^2} \left(Ax + \frac{B}{x} \right) = e^x \Rightarrow A_1 - \frac{B_1}{x^2} = e^x \quad (3)$$

Solving equations (2) and (3), we get

$$A_1 = \frac{1}{2}e^x \text{ and } B_1 = -\frac{1}{2}e^xx^2 .$$

On integrating, we get

$$A = \frac{1}{2}e^x + a \text{ and } B = -\frac{1}{2}e^x(x^2 - 2x + 2) + b .$$

Thus, the complete solution is $y = Ax + B/x$

$$\text{i.e. } y = \left(\frac{1}{2}e^x + a \right)x + \frac{1}{x} \left(-\frac{1}{2}e^x(x^2 - 2x + 2) + b \right) \Rightarrow y = ax + \frac{b}{x} + e^x - \frac{e^x}{x}$$

Q.40 Solve $(D^2 - 4D + 1)y = e^{2x} \sin 2x$ (7)

Ans:

The auxiliary equation is $m^2 - 4m + 1 = 0$ which gives $m = 2 \pm \sqrt{3}$.

Therefore, C.F. = $y = c_1e^{(2+\sqrt{3})x} + c_2e^{(2-\sqrt{3})x}$.

$$\begin{aligned} \text{Further P.I.} &= \frac{1}{D^2 - 4D + 1} e^{2x} \sin 2x = e^{2x} \frac{1}{(D+2)^2 - 4(D+2) + 1} \sin 2x \\ &= e^{2x} \frac{1}{(D)^2 - 3} \sin 2x = e^{2x} \frac{1}{-(2)^2 - 3} \sin 2x = -\frac{1}{7} e^{2x} \sin 2x. \end{aligned}$$

Hence, the general solution of the given equation is

$$y = c_1 e^{(2+\sqrt{3})x} + c_2 e^{(2-\sqrt{3})x} - \frac{1}{7} e^{2x} \sin 2x.$$

Q.41 Show that non-trivial solutions of the boundary value problem

$$y^{(iv)} - \omega^4 y = 0, y(0) = 0 = y''(0), \quad y(L) = 0 = y''(L) = 0 \text{ are } y(x) = \sum_{n=1}^{\infty} D_n \sin\left(\frac{n\pi x}{L}\right), \text{ where } D_n \text{ are constants.} \tag{9}$$

Ans:

Assume the solution to be of the form $y = e^{mx}$. The characteristic equation is given as $m^4 - \omega^4 = 0$ or $m^2 = \pm \omega^2$ or $m = \pm \omega, \pm i\omega$.

The general solution is given by

$$\begin{aligned} y(x) &= A_1 e^{\omega x} + B_1 e^{-\omega x} + C \cos \omega x + D \sin \omega x \\ &= A \cosh \omega x + B \sinh \omega x + C \cos \omega x + D \sin \omega x \end{aligned}$$

Substituting the initial conditions, we get $y(0) = A + C = 0$.

$$y'' = \omega^2 [A \cosh \omega x + B \sinh \omega x - C \cos \omega x - D \sin \omega x];$$

$$y''(0) = \omega^2 (A - C) = 0 \text{ or } A - C = 0.$$

Solving, the two equations, we get $A = 0, C = 0$. We also have

$$y(l) = 0 = B \sinh \omega l + D \sin \omega l; y''(l) = 0 = B \sinh \omega l - D \sin \omega l;$$

Adding, we obtain $2B \sinh \omega l = 0$ or $B = 0$. Therefore, we obtain

$D \sin \omega l = 0$. Since we require non-trivial solutions, we have $D \neq 0$.

Hence, $\sin \omega l = 0 = \sin n\pi, n = 1, 2, 3, \dots$

$$\text{Therefore, } \omega = \frac{n\pi}{l}, n = 1, 2, \dots$$

The solution of the boundary value problem is

$$y_n(x) = D_n \sin\left(\frac{n\pi x}{l}\right), n = 1, 2, \dots$$

By superposition principle, the solution can be written as

$$y(x) = \sum_{n=1}^{\infty} \left(D_n \sin\left(\frac{n\pi x}{l}\right) \right).$$

Q.42 Show that the matrices A and A^T have the same eigenvalues. Further if λ, μ are two distinct eigenvalues, then show that the eigenvector corresponding to λ for A is orthogonal to eigenvector corresponding to μ for A^T . (7)

Ans:

We have $|A - \lambda I| = \left| (A^T)^T - \lambda I^T \right| = \left| (A^T - \lambda I)^T \right| = |A^T - \lambda I|,$

Since A and A^T have the same characteristic equation, they have the same eigenvalues.

Let λ and μ be two distinct eigenvalues of A . Let x be the eigenvector corresponding to the eigenvalue λ for A and y be the eigenvector corresponding to the eigenvalue μ for A^T . We have $Ax = \lambda x$. Premultiplying by y^T , we get

$$y^T Ax = y^T \lambda x = \lambda y^T x, \tag{1}$$

and $A^T y = \mu y$, or $(A^T y)^T = (\mu y)^T$, or $y^T A = \mu y^T$

Post multiplying by x , we get $y^T Ax = \mu y^T x$, (2)

Subtracting equation (1) and (2), we obtain

$$(\lambda - \mu) y^T x = 0. \text{ Since } \lambda \neq \mu, \text{ we obtain } y^T x = 0.$$

Therefore, the vectors x and y are mutually orthogonal.

Q.43 Let T be a linear transformation defined by

$$T \begin{bmatrix} 1 & 1 \\ 1 & 1 \end{bmatrix} = \begin{bmatrix} 1 \\ 2 \\ 3 \end{bmatrix}, \quad T \begin{bmatrix} 0 & 0 \\ 1 & 1 \end{bmatrix} = \begin{bmatrix} 1 \\ -2 \\ -3 \end{bmatrix}.$$

$$T \begin{bmatrix} 0 & 1 \\ 1 & 1 \end{bmatrix} = \begin{bmatrix} 1 \\ -2 \\ 3 \end{bmatrix}, \quad T \begin{bmatrix} 0 & 0 \\ 0 & 1 \end{bmatrix} = \begin{bmatrix} -1 \\ 2 \\ 3 \end{bmatrix}.$$

Find $T \begin{bmatrix} 4 & 5 \\ 3 & 8 \end{bmatrix}$. (7)

Ans:

The matrices $\begin{pmatrix} 1 & 1 \\ 1 & 1 \end{pmatrix}, \begin{pmatrix} 0 & 1 \\ 1 & 1 \end{pmatrix}, \begin{pmatrix} 0 & 0 \\ 1 & 1 \end{pmatrix}, \begin{pmatrix} 0 & 0 \\ 0 & 1 \end{pmatrix}$ are linearly independent and hence form a basis in the space of 2×2 matrices. We write for any scalars $\alpha_1, \alpha_2, \alpha_3, \alpha_4$ not all zero

$$\begin{pmatrix} 4 & 5 \\ 3 & 8 \end{pmatrix} = \alpha_1 \begin{pmatrix} 1 & 1 \\ 1 & 1 \end{pmatrix} + \alpha_2 \begin{pmatrix} 0 & 1 \\ 1 & 1 \end{pmatrix} + \alpha_3 \begin{pmatrix} 0 & 0 \\ 1 & 1 \end{pmatrix} + \alpha_4 \begin{pmatrix} 0 & 0 \\ 0 & 1 \end{pmatrix}$$

$$= \begin{pmatrix} \alpha_1 & \alpha_1 + \alpha_2 \\ \alpha_1 + \alpha_2 + \alpha_3 & \alpha_1 + \alpha_2 + \alpha_3 + \alpha_4 \end{pmatrix}.$$

Comparing the elements and solving the resulting system of equations, we get $\alpha_1 = 4, \alpha_2 = 1, \alpha_3 = -2, \alpha_4 = 5$. Since T is a linear transformation, we get

$$T \left[\begin{pmatrix} 4 & 5 \\ 3 & 8 \end{pmatrix} \right] = \alpha_1 T \left[\begin{pmatrix} 1 & 1 \\ 1 & 1 \end{pmatrix} \right] + \alpha_2 T \left[\begin{pmatrix} 0 & 1 \\ 1 & 1 \end{pmatrix} \right] + \alpha_3 T \left[\begin{pmatrix} 0 & 0 \\ 1 & 1 \end{pmatrix} \right] + \alpha_4 T \left[\begin{pmatrix} 0 & 0 \\ 0 & 1 \end{pmatrix} \right]$$

$$= 4 \begin{pmatrix} 1 \\ 2 \\ 3 \end{pmatrix} + 1 \begin{pmatrix} 1 \\ -2 \\ 3 \end{pmatrix} - 2 \begin{pmatrix} 1 \\ -2 \\ -3 \end{pmatrix} + 5 \begin{pmatrix} -1 \\ 2 \\ 3 \end{pmatrix} = \begin{pmatrix} -2 \\ 20 \\ 36 \end{pmatrix}.$$

Q.44 Find the eigen values and eigenvectors of the matrix $A = \begin{bmatrix} 8 & -6 & 2 \\ -6 & 7 & -4 \\ 2 & -4 & 3 \end{bmatrix}$. **(9)**

Ans:

The characteristic equation of A is $|A - \lambda I| = 0$

$$\Rightarrow \begin{vmatrix} 8-\lambda & -6 & 2 \\ -6 & 7-\lambda & -4 \\ 2 & -4 & 3-\lambda \end{vmatrix} = 0 \text{ or } \lambda^3 - 18\lambda^2 + 45\lambda = 0$$

$$\Rightarrow \lambda(\lambda - 3)(\lambda - 15) = 0. \therefore \lambda = 0, 3, 15.$$

Thus, the eigen values of A are $\lambda_1 = 0, \lambda_2 = 3, \lambda_3 = 15$. The eigenvector X_1 of A corresponding to $\lambda_1 = 0$, is the solution of the system of equations

$$(A - \lambda_1 I)X = 0, \text{ i.e.}$$

$$8x_1 - 6x_2 + 2x_3 = 0$$

$$-6x_1 + 7x_2 - 4x_3 = 0$$

$$2x_1 - 4x_2 + 3x_3 = 0$$

Eliminating x_1 from the last two equations gives $-5x_2 + 5x_3 = 0$ or $x_2 = x_3$.

Setting $x_3 = k_1$, we get $x_2 = k_1$ and $x_1 = \frac{k_1}{2}$

Therefore, the eigenvector of A corresponding to $\lambda = 0$, is $X_1 = k_1 \begin{bmatrix} 1/2 \\ 1 \\ 1 \end{bmatrix} = k_1 \begin{bmatrix} 1 \\ 2 \\ 2 \end{bmatrix}$ ($k_1 \neq 0$)

Similarly for $\lambda = 3$, we get X_2 is

$$X_2 = k_2 \begin{bmatrix} 2 \\ 1 \\ -2 \end{bmatrix} \text{ (} k_2 \neq 0 \text{) and for } \lambda = 15, \text{ we get } X_3 \text{ as } X_3 = k_3 \begin{bmatrix} 2 \\ -2 \\ 1 \end{bmatrix} \text{ (} k_3 \neq 0 \text{).}$$

Further, since A is symmetric matrix, the eigen vectors X_1, X_2, X_3 should be mutually orthogonal. Let us verify that

$$X_1 * X_2 = (1)(2) + (2)(1) + (2)(-2) = 0.$$

$$X_2 * X_3 = (2)(2) + (1)(-2) + (-2)(1) = 0.$$

$$X_3 * X_1 = (2)(1) + (-2)(2) + (1)(2) = 0.$$

Q.45 Solve the following system of equations:

$$x_1 + 2x_2 - x_3 = 3$$

$$3x_1 - x_2 + 2x_3 = 1$$

$$2x_1 - 2x_2 + 3x_3 = 2$$

$$x_1 - x_2 + x_3 = -1$$

(6)

Ans:

The given system in the matrix equation form is $AX = B$; where

$$A = \begin{bmatrix} 1 & 2 & -1 \\ 3 & -1 & 2 \\ 2 & -2 & 3 \\ 1 & -1 & 1 \end{bmatrix}, X = \begin{bmatrix} x_1 \\ x_2 \\ x_3 \end{bmatrix}, B = \begin{bmatrix} 3 \\ 1 \\ 2 \\ -1 \end{bmatrix}$$

$$(A : B) = \begin{bmatrix} 1 & 2 & -1 & 3 \\ 3 & -1 & 2 & 1 \\ 2 & -2 & 3 & 2 \\ 1 & -1 & 1 & -1 \end{bmatrix} \sim \begin{bmatrix} 1 & 2 & -1 & 3 \\ 0 & -7 & 5 & -8 \\ 0 & -6 & 5 & -4 \\ 0 & -3 & 2 & -4 \end{bmatrix}$$

(on operating $R_2 \rightarrow R_2 - 3R_1, R_3 \rightarrow R_3 - 2R_1$ and $R_4 \rightarrow R_4 - R_1$)

$$\sim \begin{bmatrix} 1 & 2 & -1 & 3 \\ 0 & -1 & 0 & -4 \\ 0 & 0 & 1 & 4 \\ 0 & -3 & 2 & -4 \end{bmatrix} \text{ (on operating } R_2 \rightarrow R_2 - R_3 \text{ and } R_3 \rightarrow R_3 - 2R_4 \text{)}$$

$$\sim \begin{bmatrix} 1 & 2 & -1 & 3 \\ 0 & 1 & 0 & 4 \\ 0 & 0 & 1 & 4 \\ 0 & 0 & 2 & 8 \end{bmatrix} \text{ (on operating } R_2 \rightarrow -R_2 \text{ and } R_4 \rightarrow R_4 + 3R_2 \text{)}$$

$$\sim \begin{bmatrix} 1 & 2 & -1 & 3 \\ 0 & 1 & 0 & 4 \\ 0 & 0 & 1 & 4 \\ 0 & 0 & 0 & 0 \end{bmatrix} \text{ (on operating } R_4 \rightarrow R_4 - 2R_3 \text{)}$$

Therefore, rank $(A : B) = \text{rank } A = 3 = \text{number of unknowns}$, hence unique solution. To obtain this unique solution, we have

$$(A : B) \sim \begin{bmatrix} 1 & 0 & 0 & -1 \\ 0 & 1 & 0 & 4 \\ 0 & 0 & 1 & 4 \\ 0 & 0 & 0 & 0 \end{bmatrix} \text{ (on operating } R_1 \rightarrow R_1 + R_3 \text{ and } R_1 \rightarrow R_1 - 2R_2 \text{)}$$

Therefore, the unique solution is $x = -1, y = 4, z = 4$.

Q.46 Find the series solution about the origin of the differential equation

$$x^2 y'' + 6xy' + (6 + x^2)y = 0. \quad (10)$$

Ans:

We find that $x = 0$ is a regular singular point of the equation. Therefore, Frobenius series solution can be obtained.

$$\text{Let } y(x) = \sum_{n=0}^{\infty} a_n x^{n+r}, a_0 \neq 0 \text{ be solution about } x = 0$$

$$y'(x) = \sum_{n=0}^{\infty} (n+r)a_n x^{n+r-1}$$

$$y''(x) = \sum_{n=0}^{\infty} (n+r)(n+r-1)a_n x^{n+r-2}$$

Then given differential equation becomes

$$\sum_{n=0}^{\infty} (n+r)(n+r-1)a_n x^{n+r} + 6 \sum_{n=0}^{\infty} (n+r)a_n x^{n+r} + 6 \sum_{n=0}^{\infty} a_n x^{n+r} + \sum_{n=0}^{\infty} a_n x^{n+r+2} = 0$$

$$\Rightarrow \sum_{n=0}^{\infty} [(n+r)(n+r+5)+6]a_n x^{n+r} + \sum_{n=0}^{\infty} a_n x^{n+r+2} = 0.$$

The lowest degree term is the term containing x^r . Equating coefficient of x^r to zero, we get $[r(r+5)+6]a_0 = 0$ or $(r+2)(r+3) = 0$, as $a_0 \neq 0$.

The indicial roots are $r = -2, -3$. Setting the Coefficients of x^{r+1} to zero, we get $[(r+1)(r+6)+6]a_1 = 0$. For $r = -2$, a_1 is zero and for $r = -3$, a_1 is arbitrary. Therefore, the indicial root $r = -3$, gives the complete solution as the corresponding solution contains two arbitrary constants. The remaining terms are

$$\sum_{n=2}^{\infty} [(n+r)(n+r+5)+6]a_n x^{n+r} + \sum_{n=0}^{\infty} a_n x^{n+r+2} = 0.$$

Setting $n-2 = t$ in the first sum and changing the dummy variable t to n , we get

$$\sum_{n=2}^{\infty} \{[(n+r+2)(n+r+7)+6]a_{n+2} + a_n\} x^{n+r+2} = 0.$$

Setting the coefficient of x^{n+r+2} to zero, we get

$$a_{n+2} = -\frac{a_n}{(n+r+2)(n+r+7)+6}, n \geq 0.$$

We have $a_2 = -\frac{a_0}{(r+2)(r+7)+6}$, $a_3 = -\frac{a_1}{(r+3)(r+8)+6}$,

For $r = -3$, we get $a_2 = -\frac{a_0}{2}$, $a_3 = -\frac{a_1}{6}$, $a_4 = -\frac{a_0}{24}$, $a_5 = -\frac{a_1}{120}$,

The solution is given by

$$y(x) = x^{-3} \left[a_0 \left(1 - \frac{x^2}{2!} + \frac{x^4}{4!} - \dots \right) + a_1 \left(x - \frac{x^3}{3!} + \frac{x^5}{5!} - \dots \right) \right]$$

$$= (a_0 x^{-3} \cos x + a_1 x^{-3} \sin x) = a_0 y_1(x) + a_1 y_2(x)$$

For $r = -2$, we get

$$a_1 = 0, a_2 = -\frac{a_0}{6}, a_3 = -\frac{a_1}{12} = 0, a_4 = -\frac{a_2}{20} = \frac{a_0}{120}, \dots$$

Therefore, the solution is

$$y^*(x) = a_0 x^{-2} \left[1 - \frac{x^2}{3!} + \frac{x^4}{5!} - \dots \right] = a_0 x^{-3} \left[x - \frac{x^3}{3!} + \frac{x^5}{5!} - \dots \right] = a_0 y_2(x)$$

We find that the indicial root $r = -2$, product a linearly dependent solution.

Q.47 Express $f(x) = x^4 + 2x^3 - 6x^2 + 5x - 3$ in terms of Legendre polynomials. (8)

Ans:

We know that, various powers of x in terms of Legendre polynomials can be written as

$$P_0(x) = 1, P_1(x) = x, x^2 = \frac{1}{3}(2P_2 + P_0),$$

$$x^3 = \frac{1}{5}(2P_3 + 3x) = \frac{1}{5}(2P_3 + 3P_1),$$

$$x^4 = \frac{1}{35} [8P_4 + 30x^2 - 3] = \frac{1}{35} [8P_4 + 10(2P_2 + P_0) - 3P_0]$$

$$= \frac{1}{35} [8P_4 + 20P_2 + 7P_0].$$

$$\text{Therefore, } f(x) = \frac{1}{35} [8P_4 + 20P_2 + 7P_0] + \frac{2}{5} (2P_3 + 3P_1) - 2(2P_2 + P_0) + 5P_1 - 3P_0$$

$$f(x) = \frac{1}{35} [8P_4 + 28P_3 - 120P_2 + 217P_1 - 168P_0].$$

Q.48 Evaluate $\int x^{-1} J_4(x) dx$, where $J_n(x)$ denotes Bessel function of order n . (8)

Ans:

Using the recurrence relation,

$$\frac{d}{dx} [x^{-3} J_3(x)] = -x^{-3} J_4(x) \Rightarrow \int x^{-3} J_4(x) dx = -x^{-3} J_3(x)$$

$$\therefore \int x^{-1} J_4(x) dx = \int x^2 \{x^{-3} J_4(x)\} dx = x^2 \{-x^{-3} J_3(x)\} - \int 2x \{-x^{-3} J_3(x)\} dx$$

$$\int x^{-1} J_4(x) dx = -x^{-1} J_3(x) + 2 \int x^{-2} J_3(x) dx$$

Using the recurrence relation,

$$\frac{d}{dx} [x^{-2} J_2(x)] = -x^{-2} J_3(x) \Rightarrow \int x^{-2} J_3(x) dx = -x^{-2} J_2(x)$$

$$\therefore \int x^{-1} J_4(x) dx = -x^{-1} J_3(x) - 2x^{-2} J_2(x)$$

Q.49 Find the stationary value of $a^3x^2 + b^3y^2 + c^3z^2$ subject to the fulfilment of the condition $\frac{1}{x} + \frac{1}{y} + \frac{1}{z} = 1$, given a, b, c are not zero. (7)

Ans:

Let $u = a^3x^2 + b^3y^2 + c^3z^2$

$$\phi = \frac{1}{x} + \frac{1}{y} + \frac{1}{z} - 1$$

Let $F = u + \lambda\phi$ where λ is constant using Lagrange's multiplier method.

For stationary values,

$$\frac{\partial F}{\partial x} = \frac{\partial F}{\partial y} = \frac{\partial F}{\partial z} = 0 \text{ and } \frac{1}{x} + \frac{1}{y} + \frac{1}{z} = 1$$

$$\Rightarrow 2a^3x - \frac{\lambda}{x^2} = 0$$

$$2b^3y - \frac{\lambda}{y^2} = 0$$

$$2c^3z - \frac{\lambda}{z^2} = 0$$

$$\Rightarrow ax = by = cz = k$$

Then, $\frac{1}{x} + \frac{1}{y} + \frac{1}{z} = 1$ gives $a + b + c = k$

Therefore, $x = \frac{a+b+c}{a}$, $y = \frac{a+b+c}{b}$, $z = \frac{a+b+c}{c}$

Stationary value of u is

$$u = (a+b+c)^2 \left[\frac{a^3}{a^2} + \frac{b^3}{b^2} + \frac{c^3}{c^2} \right] = (a+b+c)^3.$$

Q.50 Find the volume enclosed by coordinate planes and portion of the plane $lx + my + nz = 1$ lying in the first quadrant. (7)

Ans:

The region of integration R is bounded by $x = 0$, $y = 0$, and $lx + my = 1$

{projection of $lx + my + nz = 1$ on $z = 0$ } $z = \frac{1 - lx - my}{n}$

$$\begin{aligned}
 V &= \iint_R z dx dy = \int_0^{1/l} \int_0^m \frac{1-lx-my}{n} dy dx = \frac{1}{n} \int_0^{1/l} \left[y - lxy - \frac{my^2}{2} \right]_0^m dx \\
 &= \frac{1}{n} \int_0^{1/l} \left[\frac{1-lx}{m} - \frac{lx}{m} + \frac{l^2 x^2}{m} - \frac{1}{2m} (1+l^2 x^2 - 2lx) \right] dx \\
 &= \frac{1}{mn} \int_0^{1/l} \left(\frac{1}{2} - lx + \frac{l^2 x^2}{2} \right) dx = \frac{1}{mn} \left[\frac{x}{2} - \frac{lx^2}{2} - \frac{l^2 x^3}{6} \right]_0^{1/l} \\
 |V| &= \left| \frac{1}{lmn} \left[\frac{1}{2} - \frac{1}{2} - \frac{1}{6} \right] \right| = \frac{1}{6mln}.
 \end{aligned}$$

Q.51 If the directional derivative of $\phi = ax^2y + by^2z + cz^2x$ at $(1, 1, 1)$ has maximum magnitude 15 in the direction parallel to line $\frac{x-1}{2} = \frac{y-3}{-2} = \frac{z}{1}$, find the value of a, b, c. (7)

Ans:

$$\bar{\nabla} \phi = (2axy + cz^2)\hat{i} + (2byz + ax^2)\hat{j} + (2czx + by^2)\hat{k}$$

$$\bar{\nabla} \phi_{(1,1,1)} = (2a+c)\hat{i} + (2b+a)\hat{j} + (2c+b)\hat{k}$$

This is along normal to the surface and $|\bar{\nabla} \phi|$ is the maximum directional derivative. Thus $\bar{\nabla} \phi$

is || to line $\frac{x-1}{2} = \frac{y-3}{-2} = \frac{z}{1}$.

Therefore,
$$\frac{2a+c}{2} = \frac{2b+a}{-2} = 2c+b$$

$$\Rightarrow 3a + 2b + c = 0$$

$$a + 4b + 4c = 0$$

$$\frac{a}{4} = \frac{b}{-11} = \frac{c}{10} = \lambda$$

Therefore, $a = 4\lambda$, $b = -11\lambda$, $c = 10\lambda$ and $|\bar{\nabla} \phi| = 15$

$$\Rightarrow (2a+c)^2 + (2b+a)^2 + (2c+b)^2 = 15^2$$

$$\Rightarrow \lambda^2 = \frac{15^2}{18^2 + 18^2 + 9^2} \Rightarrow \lambda = \pm \frac{5}{9}$$

Therefore, $a = \pm \frac{20}{9}$, $b = \mp \frac{55}{9}$, $c = \pm \frac{50}{9}$.

Q.52 Verify divergence theorem for the vector field $\vec{F} = 4x\hat{i} - 2y^2\hat{j} + z^2\hat{k}$ taken over the region bounded by cylinder $x^2 + y^2 = 4, z = 0, z = 3$. (7)

Ans:

By Divergence theorem,

$$\iiint_v \nabla \cdot \vec{F} dv = \iint_s \vec{F} \cdot \vec{n} ds$$

Now, $\nabla \cdot \vec{F} = (4 - 4y + 2z)$

$$\begin{aligned} \iiint_v \nabla \cdot \vec{F} dv &= \int_{-2}^2 \int_{-\sqrt{4-x^2}}^{\sqrt{4-x^2}} \int_{z=0}^3 (4 - 4y + 2z) dz dy dx \\ &= \int_{-2}^2 \int_{-\sqrt{4-x^2}}^{\sqrt{4-x^2}} (4z - 4yz + 2z^2) \Big|_0^3 dy dx = \int_{-2}^2 \int_{-\sqrt{4-x^2}}^{\sqrt{4-x^2}} (21 - 12y) dy dx \\ &= \int_{-2}^2 (21y - 6y^2) \Big|_{-\sqrt{4-x^2}}^{\sqrt{4-x^2}} dx = \int_{-2}^2 42\sqrt{4-x^2} dx = 84 \int_0^2 \sqrt{4-x^2} dx \end{aligned}$$

Let $x = 2 \sin \theta$ then $dx = 2 \cos \theta$, for $x = 0, \theta = 0$ and for $x = 2, \theta = \frac{\pi}{2}$

$$\iiint_v \nabla \cdot \vec{F} dv = 84 \int_0^{\frac{\pi}{2}} 4 \cos^2 \theta d\theta = 84 \cdot \frac{1}{2} \cdot \frac{\pi}{2} \cdot 4 = 84\pi$$

Now Surface S consists of three surfaces, the one leaving base $S_1 (z = 0)$, second leaving top $S_2 (z = 3)$, third the curved surface S_3 of cylinder $x^2 + y^2 = 4$ between $z = 0, z = 3$

$$\iint_s \vec{F} \cdot \vec{n} ds = \iint_{S_1 + S_2 + S_3} \vec{F} \cdot \vec{n} ds$$

On $S_1 : z = 0, \vec{n} = -\hat{k}, \vec{F} \cdot \vec{n} = 0$

On $S_2 : z = 3, \vec{n} = \hat{k}, \vec{F} \cdot \vec{n} = 9$

On S_3 the outer normal is in the direction of $\nabla \cdot \vec{F}$. Therefore a unit vector along normal to the curved surface is given by

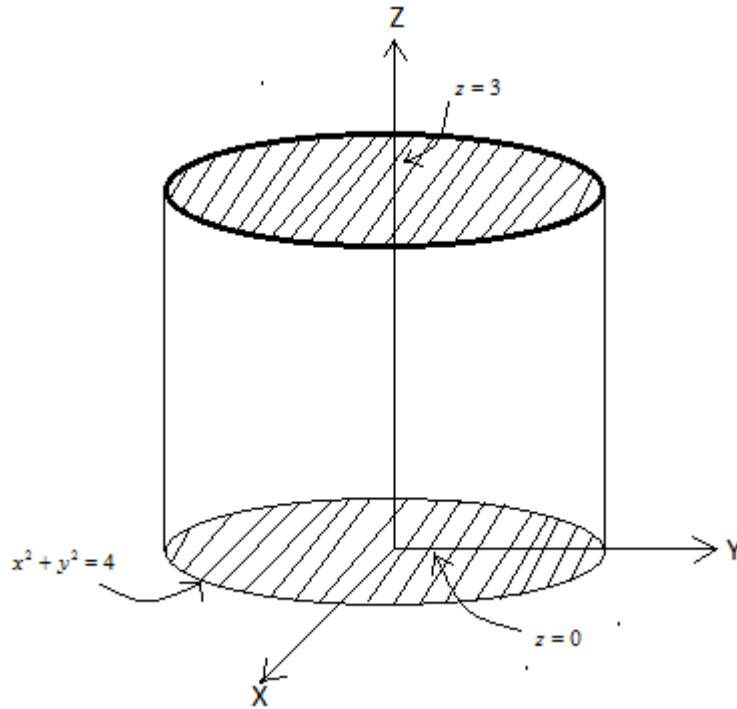

$$\hat{n} = \frac{2x\hat{i} + 2y\hat{j}}{\sqrt{4x^2 + 4y^2}} = \frac{x\hat{i} + y\hat{j}}{2}, \text{ thus } \bar{F} \cdot \bar{n} = 2x^2 - y^3$$

$$\begin{aligned} \iint_{S_3} \bar{F} \cdot \bar{n} \, dS_3 &= \iint_{S_3} (2x^2 - y^3) \, dS_3 \\ &= \int_0^{2\pi} \int_0^3 [2(2\cos\theta)^2 - (2\sin\theta)^3] \, 4dz \, d\theta \\ &= \int_0^{2\pi} (8\cos^2\theta - 8\sin^3\theta) \, d\theta \int_0^3 4dz \\ &= 48 \times 8 \int_0^{\pi/2} \cos^2\theta \, d\theta = 84\pi \end{aligned}$$

Hence divergence theorem proved.

Q.53 Show that $\int_0^\infty e^{-bx} J_0(ax) \, dx = \frac{1}{\sqrt{a^2 + b^2}}$ and hence deduce that $\int_0^\infty J_0(ax) \, dx = \frac{1}{a}$. (7)

Ans:

We know that

$$e^{\frac{x}{2}\left(\frac{z-1}{z}\right)} = J_0 + J_1\left(z - \frac{1}{z}\right) + J_2\left(z^2 - \frac{1}{z^2}\right) + \dots$$

Putting, $z = e^{i\varphi}$, Then

$$e^{i(x\sin\varphi)} = J_0 + 2i\sin\varphi J_1 + (2\cos 2\varphi)J_2 + \dots$$

Comparing real and imaginary part

$$\cos(x\sin\varphi) = J_0 + (2\cos 2\varphi)J_2 + \dots$$

Let $\varphi = \frac{\pi}{2} - \theta$ and $x = ax$

$$\cos(ax\cos\theta) = J_0(ax) - 2\cos 2\theta J_2(ax) + \dots$$

$$\int_0^\pi \cos(ax\cos\theta) d\theta = \int_0^\pi J_0(ax) d\theta = \pi J_0(ax).$$

Therefore, $J_0(ax) = \frac{1}{\pi} \int_0^\pi \cos(ax\cos\theta) d\theta$. Let $b > 0$, then

$$\begin{aligned} I = \int_0^\infty e^{-bx} J_0(ax) dx &= \frac{1}{\pi} \int_0^\infty \int_0^\pi e^{-bx} \cos(ax\cos\theta) d\theta dx \\ &= \frac{1}{\pi} \int_0^\pi \int_0^\infty e^{-bx} \cos(ax\cos\theta) dx d\theta \end{aligned}$$

$$= \frac{1}{\pi} \int_0^\pi \left[\frac{e^{-bx}}{b^2 + a^2 \cos^2 \theta} \left[-b \cos(ax\cos\theta) + a \cos\theta \sin(ax\cos\theta) \right] \right]_0^\infty d\theta$$

$$\begin{aligned} I &= \frac{b}{\pi} \int_0^\pi \frac{d\theta}{b^2 + a^2 \cos^2 \theta} \\ &= \frac{2b}{\pi} \int_0^{\pi/2} \frac{d\theta}{b^2 + a^2 \cos^2 \theta} \\ &= \frac{2}{\pi b} \int_0^\infty \frac{dt}{t^2 + \frac{a^2 + b^2}{b^2}} \end{aligned}$$

Let $\tan\theta = t$
 $d\theta = \frac{dt}{1+t^2}$

$$= \frac{2}{\pi\sqrt{a^2 + b^2}} \cdot \tan^{-1} \frac{bt}{\sqrt{a^2 + b^2}} \Big|_0^\infty = \frac{1}{\sqrt{a^2 + b^2}}$$

Hence, $\int_0^\infty e^{-bx} J_0(ax) dx = \frac{1}{\sqrt{a^2 + b^2}}$

Putting $b = 0$, we get $\int_0^{\infty} J_0(ax) dx = \frac{1}{a}$

- Q.54** Solve $\frac{\partial^2 u}{\partial x^2} + \frac{\partial^2 u}{\partial y^2} = 0$ in the interval $0 \leq x \leq \pi$ subject to the boundary conditions :
- (i) $u(0, y) = 0$
 - (ii) $u(\pi, y) = 0$
 - (iii) $u(x, 0) = 1$
 - (iv) $u(x, y) \rightarrow 0$ as $y \rightarrow \infty$ for all x . (7)

Ans:

Let $U = X(x) Y(y)$, then equation becomes

$$\frac{1}{X} \frac{d^2 X}{dx^2} + \frac{1}{Y} \frac{d^2 Y}{dy^2} = 0.$$

Let $\frac{1}{X} \frac{d^2 X}{dx^2} = -l^2$, then $\frac{1}{Y} \frac{d^2 Y}{dy^2} = l^2$

Therefore, $X = A \cos lx + B \sin lx$

$$Y = Ce^{ly} + De^{-ly}$$

$$U(x, y) = (A \cos lx + B \sin lx) (Ce^{ly} + De^{-ly})$$

(iv) condition gives $U(x, y) \rightarrow 0$ as $y \rightarrow \infty \Rightarrow C = 0$

$$\therefore U = (A \cos lx + B \sin lx) e^{-ly}$$

(i) gives $U(0, y) = 0 \Rightarrow A = 0$

Hence, $U = B \sin lx \cdot e^{-ly}$

(iii) gives $U(x, 0) = 1 \Rightarrow 1 = b_1 \sin lx$

$$b_l = \frac{2}{\pi} \int_0^{\pi} \sin lx dx = \frac{2}{\pi l} [-\cos lx]_0^{\pi}$$

$$= \frac{2}{\pi l} [1 - (-1)^l] \quad \left\{ \begin{array}{ll} \frac{4}{\pi l} & \text{if } l \text{ is odd} \\ 0 & \text{if } l \text{ is even} \end{array} \right\}$$

$$\therefore U(x, y) = \sum_{n=0}^{\infty} b_l \sin nx e^{-ny} = \frac{4}{\pi} \sum_{n=\text{odd}} \frac{1}{n} \sin nx e^{-ny}$$

$$= \frac{4}{\pi} \sum_{m=0}^{\infty} \frac{1}{(2m+1)} \sin(2m+1)x e^{-(2m+1)y}$$

Q.55 Use Cayley - Hamilton theorem to express $A^5 - 4A^4 - 7A^3 + 11A^2 - A - 10I$ in terms of A and the identity matrix I , where $A = \begin{bmatrix} 1 & 4 \\ 2 & 3 \end{bmatrix}$. (7)

Ans:

The characteristic equation of A is $|A - \lambda I| = 0$

$$\Rightarrow \lambda^2 - 4\lambda - 5 = 0$$

$$\Rightarrow A^2 - 4A - 5I = 0, \text{ by Cayley Hamilton Theorem.}$$

Thus $A^5 - 4A^4 - 7A^3 + 11A^2 - A - 10I$

$$= (A^2 - 4A - 5I)(A^3 - 2A + 3I) + A + 5I = A + 5I.$$

Q.56 Solve $(D^2 + 5D + 6)y = e^{-2x} \sec^2 x (1 + 2 \tan x)$. (7)

Ans:

$$(D^2 + 5D + 6)y = e^{-2x} \sec^2 x (1 + 2 \tan x)$$

$$\text{A.E. : } m^2 + 5m + 6 = 0$$

$$m = -2, -3$$

$$\text{C.F.} = c_1 e^{-2x} + c_2 e^{-3x}$$

$$P.I. = \frac{1}{(D+2)(D+3)} [e^{-2x} \sec^2 x (1 + 2 \tan x)]$$

$$= \frac{1}{(D+3)} [e^{-2x} \int e^{2x} \cdot e^{-2x} \sec^2 x (1 + 2 \tan x) dx]$$

$$= \frac{1}{(D+3)} [e^{-2x} (\tan x + \tan^2 x)] \left\{ \because \frac{1}{D-\alpha} X = e^{\alpha x} \int X e^{-\alpha x} dx \right\}$$

$$= e^{-3x} \int e^x (\tan x + \sec^2 x - 1) dx = e^{-3x} [e^x \tan x - e^x] = e^{-2x} (\tan x - 1)$$

Thus $y = c_1 e^{-2x} + c_2 e^{-3x} + e^{-2x} \tan x$.

Q.57 Find analytic function whose real part is $\frac{\sin 2x}{\cosh 2y - \cos 2x}$. (7)

Ans:

$$\text{Let } u = \frac{\sin 2x}{\cosh 2y - \cos 2x} \text{ and } f(z) = u + iv$$

$$\frac{\partial u}{\partial x} = \frac{(\cosh 2y - \cos 2x) 2 \cos 2x - 2 \sin^2 2x}{(\cosh 2y - \cos 2x)^2}$$

$$\frac{\partial u}{\partial y} = -\frac{2 \sin 2x \sinh 2y}{(\cosh 2y - \cos 2x)^2}$$

$f'(z) = \frac{\partial u}{\partial x} + i \frac{\partial v}{\partial x} = \frac{\partial u}{\partial x} - i \frac{\partial u}{\partial y}$, since u is an analytic function, thus it must

satisfies C-R equations, thus $\frac{\partial v}{\partial x} = -\frac{\partial u}{\partial y}$

$$f'(z) = \frac{(\cosh 2y - \cos 2x) 2 \cos 2x - 2 \sin^2 2x + i 2 \sin 2x \sinh 2y}{(\cosh 2y - \cos 2x)^2}$$

$$f'(z) = \frac{\partial u}{\partial x} - i \frac{\partial u}{\partial y}$$

$$f'(z) = \frac{(\cosh 2y - \cos 2x) 2 \cos 2x - 2 \sin^2 2x + i 2 \sin 2x \sinh 2y}{(\cosh 2y - \cos 2x)^2}$$

Using Milne's Thomson method, Let $x = z, y = 0$

$$f'(z) = \frac{2(\cos 2z - 1)}{(1 - \cos 2z)^2} = \frac{-2}{1 - \cos 2z} = -\operatorname{cosec}^2 z$$

$\therefore f(z) = \cot z + c$, where c is a constant of integration.

Q.58 Evaluate $\int_0^\infty \frac{\sin ax}{x} dx, a > 0$, using contour integration. (7)

Ans:

Consider the function $f(z) = \frac{e^{ aiz }}{z}$. It has simple pole at $z = 0$. $\int_C f(z) dz$ where C consists of

the part of real axis from $-R$ to $-r$ and from r to R , the small semi circle C_r from $-r$ to r with center at origin and radius r , which is small and large semi-circle C_R from R to $-R$ as shown in Fig. $f(z)$ is analytic inside C ($z = 0$, the only singularity has been deleted by indenting the origin by drawing C_r).

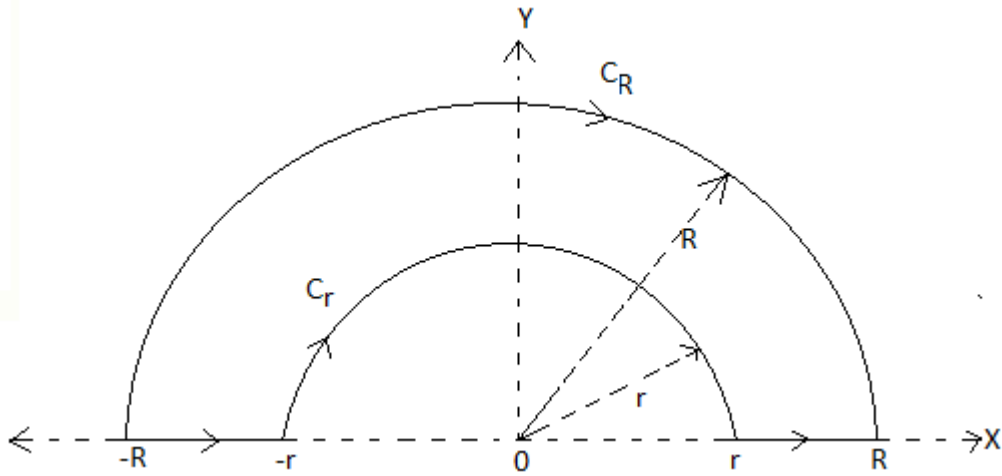

Therefore, by Cauchy's Theorem,

$$\int_r^R f(x)dx + \int_{C_R} f(z)dz + \int_{-R}^{-r} f(x)dx + \int_{C_r} f(z)dz = 0 \quad (1)$$

For C_R , we have $z = Re^{i\theta}$, $0 \leq \theta \leq \pi$ and $C_r, z = re^{i\theta}$, $0 \leq \theta \leq \pi$

$$\therefore \int_{C_R} f(z)dz = \int_0^\pi \frac{e^{aiRe^{i\theta}}}{Re^{i\theta}} \cdot R i e^{i\theta} d\theta = i \int_0^\pi e^{aiR(\cos\theta+i\sin\theta)} d\theta$$

$$\therefore \left| \int_{C_R} f(z)dz \right| \leq \int_0^\pi e^{-aR\sin\theta} d\theta = 2 \int_0^{\pi/2} e^{-aR\sin\theta} d\theta$$

Since $\frac{\sin\theta}{\theta}$ decreases from 1 to $\frac{2}{\pi}$ as θ increases from 0 to $\frac{\pi}{2}$ $\therefore \sin\theta \geq \frac{2\theta}{\pi}$

$$\therefore \left| \int_{C_R} f(z)dz \right| \leq 2 \int_0^{\pi/2} e^{-aR\frac{2\theta}{\pi}} d\theta = \frac{\pi}{2aR} [1 - e^{-aR}] \rightarrow 0 \text{ as } R \rightarrow \infty$$

$$\begin{aligned} \int_{C_r} f(z)dz &= i \int_{C_r} e^{air(\cos\theta+i\sin\theta)} d\theta \\ &= i \int_\pi^0 e^{air(\cos\theta+i\sin\theta)} d\theta \rightarrow i \int_\pi^0 e^0 d\theta = -i\pi \text{ as } r \rightarrow 0 \end{aligned}$$

$$\int_r^R f(x)dx = \int_r^R \frac{e^{aix}}{x} dx$$

$$\int_{-R}^{-r} f(x)dx = - \int_{-R}^{-r} \frac{e^{aix}}{x} dx = - \int_r^R \frac{e^{-aix}}{x} dx$$

$$\int_r^R f(x) dx + \int_{-R}^{-r} f(x) dx = \int_r^R \frac{1}{x} (e^{aix} - e^{-aix}) dx = 2i \int_r^R \frac{\sin ax}{x} dx$$

Putting values in (1) and applying limits $r \rightarrow 0, R \rightarrow \infty$, we get

$$\int_{-\infty}^{\infty} \frac{\sin ax}{x} dx = \frac{\pi}{2}$$

Q.59 In a normal distribution 31% of the items are under 45 and 8% are over 64. Find the mean and standard deviation of the distribution.

[Given that $\int_{-0.5}^0 \phi(z) dz = 0.19, \int_0^{1.4} \phi(z) dz = 0.42,$

where $\phi(z)$ is pdf of standard normal distribution.] (7)

Ans:

Since 31% of items are under 45. Hence 19% of items lies between \bar{X} and 45. Since

$$\int_{-0.5}^0 \phi(z) dz = 0.19,$$

thus, $\frac{45 - \bar{X}}{\sigma} = -0.5$. Similarly $\frac{64 - \bar{X}}{\sigma} = 1.4$

$$\therefore \bar{X} - 0.5\sigma = 45$$

$$\bar{X} + 1.4\sigma = 64$$

Solving, we get $\sigma = 10, \bar{X} = 50$.

Q.60 A can hit a target 3 times in 5 shots, B 2 times in 5 shots and C 3 times in 4 shots. All of them fire one shot each simultaneously at the target. What is the probability that (i) two shots hit (ii) atleast two shots hit? (7)

Ans:

$$p(A) = \text{Probability of hitting target by A} = 3/5$$

$$p(B) = \text{Probability of hitting target by B} = 2/5$$

$$p(C) = \text{Probability of hitting target by C} = 3/4$$

(i) $p_1 = \text{Chance A, B hit \& C fails}$
 $= p(A) \cdot p(B) \cdot \overline{p(C)} = \frac{3}{5} \cdot \frac{2}{5} \cdot \frac{1}{4} = \frac{6}{100}$

$p_2 = \text{Chance B, C hit \& A fails} = 12/100$

$p_3 = \text{Chance C, A hit \& B fails} = 27/100$

Since all these events are mutually exclusive, therefore,

$P(\text{two shots hit the target}) = p_1 + p_2 + p_3 = 0.45$

- (ii) In case atleast two shots may hit target, we must also consider case when all hit the target.

$p_4 = \text{Probability A, B, C hit target} = 18/100.$

Therefore, $P(\text{atleast two shot hit the target}) = p_1 + p_2 + p_3 + p_4 = 63/100 = 0.63.$

Q.61 Diagonalize the matrix $\begin{bmatrix} 1 & 1 & 3 \\ 1 & 5 & 1 \\ 3 & 1 & 1 \end{bmatrix}$. (7)

Ans:

The characteristic equation is $|A - \lambda I| = 0$

i.e. $\lambda^3 - 7\lambda^2 + 36 = 0$

$\Rightarrow \lambda = -2, 3, 6$

These are eigen values of given matrix A. For eigen vectors we find $X \neq 0$, such that $(A - \lambda I)$

$X = 0$

For $\lambda = -2$

$3x + y + 3z = 0$

$x + 7y + z = 0$

$\Rightarrow \frac{x}{-1} = \frac{y}{0} = \frac{z}{1}$

Therefore, for $\lambda = -2$, eigen vector is $(-1, 0, 1)'$

Similarly for $\lambda = 3$, eigen vector is $(1, -1, 1)'$

for $\lambda = 6$, eigen vector is $(1, 2, 1)'$

The modal matrix P is given by

$$P = \begin{bmatrix} -1 & 1 & 1 \\ 0 & -1 & 2 \\ 1 & 1 & 1 \end{bmatrix}$$

$$\Rightarrow P^{-1} = \frac{1}{6} \begin{bmatrix} -3 & 0 & 3 \\ 2 & -2 & 2 \\ 1 & 2 & 1 \end{bmatrix}$$

The diagonal matrix D is given by

$$D = P^{-1}AP = \begin{bmatrix} -2 & 0 & 0 \\ 0 & 3 & 0 \\ 0 & 0 & 6 \end{bmatrix}$$

Q.62 Investigate the values of λ and μ so that equations

$$2x + 3y + 5z = 9,$$

$$7x + 3y - 2z = 8,$$

$$2x + 3y + \lambda z = \mu.$$

have (i) no solution (ii) a unique solution (iii) infinite number of solutions. (7)

Ans:

$$\text{We have } \begin{bmatrix} 2 & 3 & 5 \\ 7 & 3 & -2 \\ 2 & 3 & \lambda \end{bmatrix} \begin{bmatrix} x \\ y \\ z \end{bmatrix} = \begin{bmatrix} 9 \\ 8 \\ \mu \end{bmatrix}$$

i.e. $AX = B$

$$(i) \quad (A : B) = \begin{bmatrix} 2 & 3 & 5 & : & 9 \\ 7 & 3 & -2 & : & 8 \\ 2 & 3 & \lambda & : & \mu \end{bmatrix}$$

$$R_3 \rightarrow R_3 - R_1, \quad R_2 \rightarrow 7R_1 - 2R_2$$

$$= \begin{bmatrix} 2 & 3 & 5 & : & 9 \\ 0 & 15 & 39 & : & 47 \\ 0 & 0 & \lambda - 5 & : & \mu - 9 \end{bmatrix}$$

If $\lambda = 5$, system will have no solution for those values of μ , for which $\text{rank } A \neq \text{rank } (A : B)$. If

$\lambda = 5, \mu \neq 9$, then $\text{rank } (A) = 2$ and $\text{rank } (A : B) = 3$. Hence no solution

(ii) The system admits unique solution iff coefficient matrix is of rank 3

$$\therefore \begin{vmatrix} 2 & 3 & 5 \\ 7 & 3 & -2 \\ 2 & 3 & \lambda \end{vmatrix} = 15(5 - \lambda) \neq 0$$

Thus for unique solution $\lambda \neq 5$ and μ may have any value.

(iii) If $\lambda = 5, \mu = 9$, system of equation have infinitely many solution

Q.63 The height h and semi vertical angle α of a cone are measured and the total area A of surface of cone including that of base is calculated in terms of h, α . If h and α are in error by small quantities δh and $\delta \alpha$ respectively, find the corresponding error in the area.

Show further that if $\alpha = \frac{\pi}{6}$ an error of +1% in h will be approximately compensated by an error of -0.33 degrees in α . (7)

Ans:

Let r be base radius and l be slant height of cone.

Total area $A =$ area of base + area of curved surface

$$= \pi r^2 + \pi r l = \pi r (r + l) = \pi h^2 \tan \alpha (\tan \alpha + \sec \alpha)$$

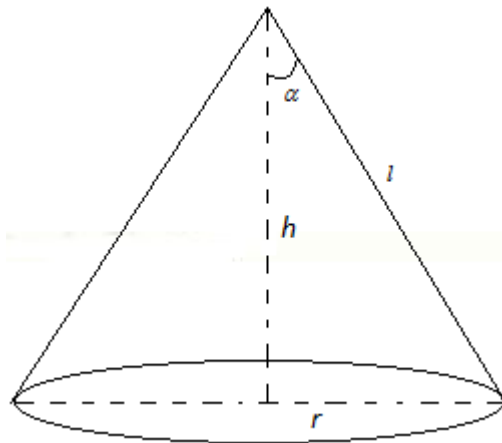

$$\delta A = 2\pi h (\tan^2 \alpha + \tan \alpha \sec \alpha) \delta h + \pi h^2 (2 \tan \alpha \sec^2 \alpha + \sec^3 \alpha + \tan^2 \alpha \sec \alpha) \delta \alpha$$

$$\therefore \delta h = \frac{h}{100}, \quad \alpha = \frac{\pi}{6}$$

$$\therefore \delta A = \frac{\pi h^2}{50} + 2\sqrt{3} \pi h^2 \delta \alpha$$

The error in h will be compensated by error in α , when

$$\delta A = 0 \quad \Rightarrow 2 \cdot \frac{\pi h^2}{100} + 2\sqrt{3} \pi h^2 \delta \alpha = 0$$

$$\Rightarrow \delta \alpha = \frac{-1}{100\sqrt{3}} \text{ radians} = -0.33^\circ$$

Q.64 If $\theta = t^n e^{-r^2/4t}$, what values of n will make $\frac{1}{r^2} \frac{\partial}{\partial r} \left[r^2 \frac{\partial \theta}{\partial r} \right] = \frac{\partial \theta}{\partial t}$? (7)

Ans:

$$\theta = t^n e^{-r^2/4t} \quad - \quad (A)$$

Differentiating (A) partially w.r.t. t, we get

$$\frac{\partial \theta}{\partial t} = e^{-r^2/4t} \left[nt^{n-1} + \frac{1}{4} r^2 t^{n-2} \right] \quad - \quad (1)$$

Differentiating (A) partially w.r.t. r, we get

$$\begin{aligned} \frac{\partial \theta}{\partial r} &= -\frac{1}{2} r t^{n-1} e^{-r^2/4t} \\ r^2 \frac{\partial \theta}{\partial r} &= -\frac{1}{2} r^3 t^{n-1} e^{-r^2/4t} \\ \frac{\partial}{\partial r} \left(r^2 \frac{\partial \theta}{\partial r} \right) &= -\frac{3}{2} r^2 t^{n-1} e^{-r^2/4t} + \frac{r^4}{4} t^{n-2} e^{-r^2/4t} \end{aligned}$$

$$\frac{1}{r^2} \frac{\partial}{\partial r} \left(r^2 \frac{\partial \theta}{\partial r} \right) = e^{-r^2/4t} \left[\frac{-3}{2} t^{n-1} + \frac{r^2}{4} t^{n-2} \right] \quad - \quad (2)$$

equating (1) and (2), we get $n = -3/2$.

Q.65 A vector field is given by $\vec{F} = (x^2 - y^2 + x)\hat{i} - (2xy + y)\hat{j}$. Show that the field is irrotational and find its scalar potential. Hence evaluate line integral $\int \vec{F} \cdot d\vec{r}$ from (1, 2) to (2, 1). (7)

Ans:

$$\text{Curl } \vec{F} = \vec{\nabla} \times \vec{F}$$

$$\begin{aligned} &= \begin{vmatrix} \hat{i} & \hat{j} & \hat{k} \\ \frac{\partial}{\partial x} & \frac{\partial}{\partial y} & \frac{\partial}{\partial z} \\ x^2 - y^2 + x & -(2xy + y) & 0 \end{vmatrix} \\ &= \hat{i}(0) - \hat{j}(0) + \hat{k}(-2y + 2y) = 0. \end{aligned}$$

\therefore vector field \vec{F} is irrotational then \exists a scalar function ϕ s.t. $\vec{F} = \vec{\nabla} \phi$

$$\therefore \frac{\partial \phi}{\partial x} = x^2 - y^2 + x, \quad \frac{\partial \phi}{\partial y} = -(2xy + y)$$

Integrating, we get

$$\varphi = \frac{x^3}{3} - xy^2 + \frac{x^2}{2} + f(y), \quad \varphi = -xy^2 - \frac{y^2}{2} + g(x)$$

$$\therefore \varphi = \frac{x^3}{3} - xy^2 + \frac{x^2 - y^2}{2} + c$$

Because, field is irrotational

$$\begin{aligned} \therefore \int_{(1,2)}^{(2,1)} \vec{F} \cdot d\vec{r} &= \int_{(1,2)}^{(2,1)} \vec{\nabla} \varphi \cdot d\vec{r} \\ &= \varphi \Big|_{(1,2)}^{(2,1)} = \left[\frac{x^3}{3} - xy^2 + \frac{x^2 - y^2}{2} \right]_{(1,1)}^{(2,1)} \\ &= \left[\frac{8}{3} - 2 + \frac{4-1}{2} \right] - \left[\frac{1}{3} - 4 + \frac{1-4}{2} \right] = \frac{7}{3} + 2 + 3 = \frac{22}{3} \end{aligned}$$

Q.66 Solve $\frac{dz}{dx} + \left(\frac{z}{x}\right) \log z = \frac{z}{x} (\log z)^2$. (7)

Ans:

$$\frac{1}{z(\log z)^2} \frac{dz}{dx} + \frac{1}{\log z} \cdot \frac{1}{x} = \frac{1}{x}$$

Let $\frac{1}{\log z} = t$

$$\therefore -\frac{1}{z(\log z)^2} \frac{dz}{dx} = \frac{dt}{dx}$$

$$\therefore \frac{dt}{dx} - \frac{t}{x} = -\frac{1}{x}$$

$$I.F. = e^{-\int \frac{1}{x} dx} = \frac{1}{x}$$

Therefore, solution is

$$t \cdot \frac{1}{x} = \int \frac{1}{x} \left(-\frac{1}{x}\right) dx + c$$

$$\Rightarrow t = 1 + cx$$

$$\Rightarrow (\log z)^{-1} = 1 + cx \quad \text{or} \quad z = e^{\frac{1}{1+cx}}$$

Q.67 Express $J_4(x)$ in terms of $J_0(x)$ and $J_1(x)$. (7)

Ans:

We know

$$J_n(x) = \frac{x}{2n}(J_{n-1} + J_{n+1})$$

$$\Rightarrow J_{n+1}(x) = \frac{2n}{x}J_n - J_{n-1}$$

For $n = 1, 2, 3$

$$J_2(x) = \frac{2}{x}J_1 - J_0$$

$$J_3(x) = \frac{4}{x}J_2 - J_1, \quad J_4(x) = \frac{6}{x}J_3(x) - J_2$$

$$J_4(x) = \left(\frac{24}{x^2} - 1\right)\left(\frac{2}{x}J_1(x) - J_0(x)\right) - \frac{6}{x}J_1(x)$$

$$J_4(x) = \left(\frac{48}{x^3} - \frac{8}{x}\right)J_1(x) + \left(1 - \frac{24}{x^2}\right)J_0(x)$$

Q.68 Find Taylor's expansion of $f(z) = \frac{2z^3 + 1}{z^2 + z}$ about the point $z = i$. (7)

Ans:

$$f(z) = \frac{2z^3 + 1}{z(z+1)} = 2z - 2 + \frac{2z+1}{z(z+1)}$$

We have to expand about $z = i$

$$\text{Let } z - i = t \therefore f(z) = 2i - 2 + 2(z - i) + \frac{1}{z} + \frac{1}{z+1}$$

$$\frac{1}{z} = \frac{1}{t+i} = \frac{1}{i} + t + \frac{t^2}{i^3} + \dots$$

$$= -i + (z - i) + \sum_{n=2}^{\infty} (-1)^n \frac{(z - i)^n}{i^{n+1}}$$

$$\frac{1}{z+1} = \frac{1}{2} - \frac{i}{2} - \frac{(z - i)}{2i} + \sum_{n=2}^{\infty} (-1)^n \frac{(z - i)^n}{(1+i)^{n+1}}$$

$$\therefore f(z) = \frac{i-3}{2} + \left(3 + \frac{i}{2}\right)(z-i) + \sum_{n=2}^{\infty} (-1)^n \left\{ \frac{1}{i^{n+1}} + \frac{1}{(1+i)^{n+1}} \right\} (z-i)^n$$

Q.69 Examine the following system of equations for consistency :

$$\begin{aligned} 3x + 3y + 2z &= 1 \\ x + 2y &= 4 \\ 10y + 3z &= -2 \\ 2x - 3y - z &= 5 \end{aligned}$$

Reduce the augmented matrix of the above system of equations to Echelon form and find the solution of the above system, if it exists. (7)

Ans:

The system of equations can be written as $AX = B$

$$\text{where } A = \begin{bmatrix} 3 & 3 & 2 \\ 1 & 2 & 0 \\ 0 & 10 & 3 \\ 2 & -3 & -1 \end{bmatrix} \quad X = \begin{bmatrix} x \\ y \\ z \end{bmatrix} \quad B = \begin{bmatrix} 1 \\ 4 \\ -2 \\ 5 \end{bmatrix}$$

Augmented matrix = $[A : B]$

$$[A : B] = \begin{bmatrix} 3 & 3 & 2 & : & 1 \\ 1 & 2 & 0 & : & 4 \\ 0 & 10 & 3 & : & -2 \\ 2 & -3 & -1 & : & 5 \end{bmatrix}$$

$$R_2 \longleftrightarrow R_1$$

$$= \begin{bmatrix} 1 & 2 & 0 & : & 4 \\ 3 & 3 & 2 & : & 1 \\ 0 & 10 & 3 & : & -2 \\ 2 & -3 & -1 & : & 5 \end{bmatrix}$$

$$R_2 \longrightarrow R_2 - 3R_1 \quad , \quad R_4 \longrightarrow R_4 - 2R_1$$

$$= \begin{bmatrix} 1 & 2 & 0 & : & 4 \\ 0 & -3 & 2 & : & -11 \\ 0 & 10 & 3 & : & -2 \\ 0 & -7 & -1 & : & -3 \end{bmatrix}$$

$$R_3 \longrightarrow 3R_3 + 10R_2 \quad , \quad R_4 \longrightarrow 7R_2 - 3R_4$$

$$[A : B] = \begin{bmatrix} 1 & 2 & 0 & 4 \\ 0 & -3 & 2 & -11 \\ 0 & 0 & 29 & -116 \\ 0 & 0 & 17 & -68 \end{bmatrix}$$

$$R_4 \longrightarrow 29R_4 - 17R_3$$

$$[A : B] = \begin{bmatrix} 1 & 2 & 0 & 4 \\ 0 & -3 & 2 & -11 \\ 0 & 0 & 29 & -116 \\ 0 & 0 & 0 & 0 \end{bmatrix}$$

This is row Echelon Form of A. Since the number of non-zero rows in the row-echelon form is 3. So,

$$\rho(A : B) = 3 = \rho(A)$$

Hence system of equations has unique solution, and is given by solving

$$x + 2y = 4$$

$$-3y + 2z = -11$$

$$29z = -116$$

$$\Rightarrow z = -4, \quad y = 1, \quad x = 2$$

Q.70 Find the eigen values and the corresponding eigen vectors of the matrix A defined by

$$A = \begin{pmatrix} 2 & 2 & 1 \\ 1 & 3 & 1 \\ 1 & 2 & 2 \end{pmatrix}$$

Obtain the modal matrix and reduce the given matrix to the diagonal matrix. (7)

Ans:

Characteristic equation is $|A - \lambda I| = 0$

$$|A - \lambda I| = \begin{vmatrix} 2-\lambda & 2 & 1 \\ 1 & 3-\lambda & 1 \\ 1 & 2 & 2-\lambda \end{vmatrix} = 0$$

$$\Rightarrow \lambda^3 - 7\lambda^2 + 11\lambda - 5 = 0$$

$$\lambda = 1, 1, 5$$

Eigen values of matrix A are 1, 1, 5

For $\lambda = 5$, eigen vector is obtained by solving the system of equations

$$\begin{bmatrix} -3 & 2 & 1 \\ 1 & -2 & 1 \\ 1 & 2 & -3 \end{bmatrix} \begin{bmatrix} x \\ y \\ z \end{bmatrix} = \begin{bmatrix} 0 \\ 0 \\ 0 \end{bmatrix}$$

i.e. $-3x + 2y + z = 0$

$x - 2y + z = 0$

$x + 2y - 3z = 0$

Solving, we get $\frac{x}{4} = \frac{y}{4} = \frac{z}{4}$

i.e. eigen vector is $(1, 1, 1)'$

For $\lambda = 1$, eigen vector is obtained by solving the system of equations

$$\begin{bmatrix} 1 & 2 & 1 \\ 1 & 2 & 1 \\ 1 & 2 & 1 \end{bmatrix} \begin{bmatrix} x \\ y \\ z \end{bmatrix} = \begin{bmatrix} 0 \\ 0 \\ 0 \end{bmatrix}$$

i.e. $x + 2y + z = 0$

There are two linearly independent eigen vectors for $\lambda = 1$. These are obtained by putting $x=0$ and $y=0$ respectively in the equation.

For $x = 0$, $2y + z = 0$

Eigen vector is $(0, -1, 2)'$

For $y = 0$, Eigen vector is $(-1, 0, 1)'$

$$\therefore \text{Modal Matrix} = P = \begin{bmatrix} 0 & -1 & 1 \\ -1 & 0 & 1 \\ 2 & 1 & 1 \end{bmatrix}$$

$$P^{-1} = \frac{1}{4} \begin{bmatrix} 1 & -2 & 1 \\ -3 & 2 & 1 \\ 1 & 2 & 1 \end{bmatrix}$$

$$\therefore \text{Diagonal Matrix} = D = P^{-1}AP$$

$$= \begin{bmatrix} 1 & 0 & 0 \\ 0 & 1 & 0 \\ 0 & 0 & 5 \end{bmatrix}$$

Q.71 If $u - v = \frac{\cos x + \sin x - e^{-y}}{2 \cos x - e^y - e^{-y}}$ and $f(z) = u + iv$ is an analytic function of $z = x + iy$, find $f(z)$ subject to the condition that at $z = \frac{\pi}{2}$, $f(z) = 0$. (7)

Ans:

$$u - v = \frac{\cos x + \sin x - e^{-y}}{2(\cos x - \cos hy)} \quad \left\{ \because e^y + e^{-y} = 2 \cos hy \right\}$$

Then $\frac{\partial u}{\partial x} - \frac{\partial v}{\partial x} = \frac{(\sin x - \cos x) \cos hy + 1 - e^{-y} \sin x}{2(\cos x - \cos hy)^2}$ - (1)

$$\frac{\partial u}{\partial y} - \frac{\partial v}{\partial y} = \frac{(\cos x - \cos hy) e^{-y} + (\cos x + \sin x - e^{-y}) \sin hy}{2(\cos x - \cos hy)^2}$$

By C.R. equations, $\frac{\partial u}{\partial x} = \frac{\partial v}{\partial y}$, $\frac{\partial u}{\partial y} = -\frac{\partial v}{\partial x}$

$$\Rightarrow -\frac{\partial v}{\partial x} - \frac{\partial u}{\partial x} = \frac{(\sin x + \cos x) \sin hy + e^{-y} (\cos x - \cos hy - \sin hy)}{2(\cos x - \cos hy)^2}$$
 -(2)

Subtracting (2) from (1)

$$2 \frac{\partial u}{\partial x} = \left[\frac{(\sin x - \cos x) \cos hy - (\sin x + \cos x) \sin hy + 1 - e^{-y} (\sin x + \cos x - \sin hy - \cos hy)}{2(\cos x - \cos hy)^2} \right]$$
 - (3)

Adding (1) and (2)

$$-2 \frac{\partial v}{\partial x} = \left[\frac{(\sin x - \cos x) \cos hy + (\sin x + \cos x) \sin hy + 1 + e^{-y} (-\sin x + \cos x - \sin hy - \cos hy)}{2(\cos x - \cos hy)^2} \right]$$
 -(4)

$$f'(z) = \frac{\partial u}{\partial x} + i \frac{\partial v}{\partial x}$$

Using Milne’s Thomson method, putting $x = z$, $y = 0$ in (3) and (4), we get

$$f'(z) = \frac{1 - \cos z}{2(1 - \cos z)^2} = \frac{1}{4} \operatorname{cosec}^2\left(\frac{z}{2}\right)$$

$$f(z) = -\frac{1}{2} \cot \frac{z}{2} + c$$

$$\therefore z = \frac{\pi}{2}, f(z) = 0 \quad \Rightarrow c = \frac{1}{2} \quad \therefore f(z) = \frac{1}{2} \left(1 - \cot \frac{z}{2}\right)$$

Q.72 Prove that the relation $W = \frac{iz + 2}{4z + i}$ transforms the real axis in the z -plane into a circle in the w -plane. Find the centre and the radius of the circle and the point in the z -plane which is mapped on the centre of the circle. (7)

Ans:

Since,
$$\omega = \frac{iz + 2}{4z + i}$$

$$\Rightarrow z = \frac{2 - i\omega}{4\omega - i}$$

$$\Rightarrow x + iy = \frac{2 - i(u + iv)}{4(u + iv) - i} = \frac{[4u(2 + v) - u(4v - 1)] - i[4u^2 + (2 + v)(4v - 1)]}{(4v - 1)^2 + 16u^2}$$

$$\therefore x = \frac{9u}{16u^2 + (4v - 1)^2}, \quad y = \frac{4(u^2 + v^2) + 7v - 2}{16u^2 + (4v - 1)^2}$$

Thus image of real axis in the z plane (means $y = 0$) is given by

$$4(u^2 + v^2) + 7v - 2 = 0$$

$$\text{i.e. } u^2 + \left(v + \frac{7}{8}\right)^2 = \left(\frac{9}{8}\right)^2$$

which is an equation of circle with centre at $\left(0, -\frac{7}{8}\right)$ and radius $\frac{9}{8}$

For $u = 0$, $v = -\frac{7}{8}$, we get $x = 0$, $y = \frac{1}{4}$. Thus centre of circle in ω plane is image of point

$$\left(0, \frac{1}{4}\right) \text{ in } z \text{ plane.}$$

Q.73 Solve in series the differential equation :

$$x(1-x)\frac{d^2y}{dx^2} + 4\frac{dy}{dx} + 2y = 0 \tag{8}$$

Ans:

$x = 0$ is a regular singular point.

Let $y(x) = \sum_{m=0}^{\infty} C_m x^{m+r}$, $C_0 \neq 0$

$$y' = \sum_{m=0}^{\infty} C_m (m+r) x^{m+r-1}$$

$$y'' = \sum_{m=0}^{\infty} C_m (m+r)(m+r-1) x^{m+r-2}$$

Substituting in the given differential equation

$$\sum_{m=0}^{\infty} \left[C_m (m+r)(m+r-1) x^{m+r-1} - C_m (m+r)(m+r-1) x^{m+r} \right. \\ \left. + 4(m+r) C_m x^{m+r-1} + 2C_m x^{m+r} \right] = 0$$

$$\Rightarrow \sum_{m=0}^{\infty} \left[2 - (m+r)(m+r-1) \right] C_m x^{m+r} + \sum_{m=0}^{\infty} C_m x^{m+r-1} (m+r)(m+r+3) = 0$$

The lowest power of x is x^{r-1} . Its coefficient equated to zero gives $C_0 r(r+3) = 0$. Because $C_0 \neq 0$

$$\Rightarrow r = 0, \quad r = -3$$

The coefficient of x^{m+r} is equated to zero gives

$$C_{m+1} = \frac{(m+r)(m+r-1) - 2}{(m+r+1)(m+r+4)} C_m$$

$$C_{m+1} = \frac{m+r-2}{m+r+4} C_m$$

$$C_1 = \frac{r-2}{r+4} C_0, \quad C_2 = \frac{r-1}{r+5} C_1 = \frac{r-1}{r+5} \cdot \frac{r-2}{r+4} C_0$$

$$C_3 = \frac{r-1}{r+5} \cdot \frac{r-2}{r+4} \cdot \frac{r}{r+6} C_0$$

When $r = 0$ $C_1 = -\frac{1}{2} C_0$, $C_2 = \frac{1}{10} C_0$, $C_3 = 0$, -----

$\therefore y_1 = x^r (C_0 + C_1 x + C_2 x^2)$, for $r = 0$. Thus one solution is

$$y_1 = C_0 \left(1 - \frac{1}{2}x + \frac{1}{10}x^2 \right)$$

When $r = -3$, $C_1 = -5C_0$, $C_2 = 10C_0$, $C_3 = -10C_0$, $C_4 = 5C_0$ -----

Thus $y_2 = C_0 x^{-3} (1 - 5x + 10x^2 - 10x^3 - \dots)$ is another solution.

$y = C_1 y_1 + C_2 y_2$ is general solution.

Q.74 Prove that

$$\int x J_0^2(x) dx = \frac{1}{2} x^2 \{ J_0^2(x) + J_1^2(x) \} + c$$

where c is an arbitrary constant.

(6)

Ans:

$$\begin{aligned} \int x J_0^2(x) dx &= \frac{x^2}{2} J_0^2(x) - \int x^2 J_0 J_0' dx \\ &= \frac{x^2}{2} J_0^2(x) + \int x^2 J_0(x) J_1(x) dx \quad \left\{ \because J_0'(x) = -J_1(x) \right\} \\ &= \frac{x^2}{2} J_0^2(x) + \int x J_1(x) \frac{d}{dx} (x J_1) dx \quad \left\{ \because (x J_1)' = x J_0 \right\} \\ &= \frac{x^2}{2} J_0^2(x) + \frac{x^2}{2} J_1^2(x) + c \end{aligned}$$

Q.75 Show that the vector field represented by

$$\vec{F} = (z^2 + 2x + 3y) \vec{i} + (3x + 2y + z) \vec{j} + (y + 2zx) \vec{k}$$

is irrotational but not solenoidal. Also obtain a scalar ϕ function such that $\text{grad } \phi = \vec{F}$.

(5)

Ans:

$$\vec{F} = (z^2 + 2x + 3y) \hat{i} + (3x + 2y + z) \hat{j} + (y + 2zx) \hat{k}$$

$$\text{div } \vec{F} = \vec{\nabla} \cdot \vec{F} = \left(\frac{\partial}{\partial x} \hat{i} + \frac{\partial}{\partial y} \hat{j} + \frac{\partial}{\partial z} \hat{k} \right) \cdot \vec{F}$$

$$\vec{\nabla} \cdot \vec{F} = 2 + 2 + 2x \neq 0 \text{ except for } x = -2.$$

Therefore, given vector field is not solenoidal.

$$\text{Curl } \vec{F} = \vec{\nabla} \times \vec{F} = \begin{vmatrix} \hat{i} & \hat{j} & \hat{k} \\ \frac{\partial}{\partial x} & \frac{\partial}{\partial y} & \frac{\partial}{\partial z} \\ z^2 + 2x + 3y & 3x + 2y + z & y + 2zx \end{vmatrix}$$

$$= \hat{i}(1-1) - \hat{j}(2z-2z) + \hat{k}(3-3) = 0$$

∴ Given vector field is irrotational. Thus it can be expressed as $\vec{F} = \vec{\nabla} \phi$, where ϕ is scalar function.

$$\therefore \frac{\partial \phi}{\partial x} = z^2 + 2x + 3y, \quad \frac{\partial \phi}{\partial y} = 3x + 2y + z, \quad \frac{\partial \phi}{\partial z} = y + 2zx$$

Integrating w.r.t. x, y, z we get

$$\phi = \begin{cases} z^2x + x^2 + 3xy + f_1(y, z) \\ \frac{3x^2}{2} + y^2 + zy + f_2(x, z) \\ yz + z^2x + f_3(x, y) \end{cases}$$

Since these three must be equal

$$\therefore \phi = x^2 + y^2 + 3xy + yz + z^2x + c$$

Q.76 If $u = f(r)$ and $r^2 = x^2 + y^2 + z^2$, show that $\nabla^2 u = f''(r) + \frac{2}{r} f'(r)$. Also show that $u = A + \frac{B}{r}$ is a possible solution of $\nabla^2 u = 0$ where A and B are arbitrary constants.

(5)

Ans:

$$u = f(r)$$

$$\vec{\nabla} u = \vec{\nabla} f(r) = \frac{\partial f(r)}{\partial r} \cdot \frac{\vec{r}}{r} = f'(r) \frac{\vec{r}}{r}$$

$$\vec{\nabla}^2 u = \vec{\nabla} \cdot \left(f'(r) \frac{\vec{r}}{r} \right) = \vec{\nabla} \cdot \left(\frac{f'(r)}{r} \vec{r} \right) + \frac{f'(r)}{r} \vec{\nabla} \cdot \vec{r}$$

$$= \frac{1}{r} \frac{d}{dr} \left(\frac{f'(r)}{r} \right) \cdot r + 3 \frac{f'(r)}{r} = \frac{1}{r} \left(\frac{rf''(r) - f'(r)}{r^2} \right) r^2 + 3 \frac{f'(r)}{r}$$

$$= f''(r) + \frac{2f'(r)}{r}$$

We know that $f(r) = A + \frac{B}{r}$, satisfies $f''(r) + \frac{2f'(r)}{r} = 0$

$$\nabla^2 u = \frac{d^2}{dr^2} \left(A + \frac{B}{r} \right) + \frac{2d}{rdr} \left(A + \frac{B}{r} \right) = \frac{2B}{r^3} - \frac{2}{r} \cdot \frac{B}{r^2} = 0$$

Q.77 Evaluate $\iiint_{\Delta} \vec{F} \cdot \vec{ds}$ where $\vec{F} = z \vec{i} + x \vec{j} - 3y^2 z \vec{k}$ and s is the surface of the cylinder $x^2 + y^2 = 16$ included in the first octant between $z = 0$ and $z = 5$. (4)

Ans:

$$\begin{aligned} \iint_s \vec{F} \cdot \vec{ds} &= \iiint_v \text{div} \vec{F} dv = \iiint_v -3y^2 dx dy dz \\ &= \int_0^4 \int_0^{\sqrt{16-x^2}} \int_0^5 -3y^2 dx dy dz \\ &= \int_0^4 -5(16-x^2)^{3/2} dx. \text{ Let } x = 4 \cos \theta, dx = -4 \sin \theta \end{aligned}$$

when $x \rightarrow 0, \theta \rightarrow 0$, and as $x \rightarrow 4, \theta \rightarrow \pi/2$

$$= -5 \int_0^{\pi/2} 4^4 \cos^4 \theta d\theta = -5 \times 4^4 \frac{3}{4} \frac{1}{2} \frac{\pi}{2} = -240\pi$$

Q.78 If $x + y = 2e^\theta \cos \phi$, $x - y = 2\sqrt{-1} e^\theta \sin \phi$, then show that $\frac{\partial^2 u}{\partial \theta^2} + \frac{\partial^2 u}{\partial \phi^2} = 4xy \frac{\partial^2 u}{\partial x \partial y}$. (7)

Ans:

Given $x + y = 2e^\theta \cos \phi$

$$x - y = 2i e^\theta \sin \phi$$

Adding & subtracting respectively, we get

$$x = e^{\theta+i\phi}, \quad y = e^{\theta-i\phi}$$

Let $u = u(x, y)$, $x = f(\theta, \phi)$, $y = G(\theta, \phi)$

$$\begin{aligned} \frac{\partial u}{\partial \theta} &= \frac{\partial u}{\partial x} \cdot \frac{\partial x}{\partial \theta} + \frac{\partial u}{\partial y} \cdot \frac{\partial y}{\partial \theta} \\ &= \frac{\partial u}{\partial x} e^{\theta+i\phi} + \frac{\partial u}{\partial y} e^{\theta-i\phi} \end{aligned}$$

$$\frac{\partial u}{\partial \theta} = x \frac{\partial u}{\partial x} + y \frac{\partial u}{\partial y}$$

Similarly $\frac{\partial u}{\partial \phi} = i \left(x \frac{\partial u}{\partial x} - y \frac{\partial u}{\partial y} \right)$

$$\begin{aligned} \frac{\partial^2 u}{\partial \theta^2} &= \frac{\partial}{\partial x} \left(\frac{\partial u}{\partial \theta} \right) \frac{\partial x}{\partial \theta} + \frac{\partial}{\partial y} \left(\frac{\partial u}{\partial \theta} \right) \frac{\partial y}{\partial \theta} \\ &= \frac{\partial}{\partial x} \left(x \frac{\partial u}{\partial x} + y \frac{\partial u}{\partial y} \right) x + \frac{\partial}{\partial y} \left(x \frac{\partial u}{\partial x} + y \frac{\partial u}{\partial y} \right) y \\ &= x \frac{\partial u}{\partial x} + x^2 \frac{\partial^2 u}{\partial x^2} + xy \frac{\partial^2 u}{\partial x \partial y} + xy \frac{\partial^2 u}{\partial x \partial y} + y \frac{\partial u}{\partial y} + y^2 \frac{\partial^2 u}{\partial y^2} \end{aligned}$$

$$\frac{\partial^2 u}{\partial \theta^2} = x^2 \frac{\partial^2 u}{\partial x^2} + y^2 \frac{\partial^2 u}{\partial y^2} + 2xy \frac{\partial^2 u}{\partial x \partial y} + x \frac{\partial u}{\partial x} + y \frac{\partial u}{\partial y}$$

Similarly $\frac{\partial^2 u}{\partial \phi^2} = - \left[x \frac{\partial u}{\partial x} + y \frac{\partial u}{\partial y} - 2xy \frac{\partial^2 u}{\partial x \partial y} + x^2 \frac{\partial^2 u}{\partial x^2} + y^2 \frac{\partial^2 u}{\partial y^2} \right]$

Adding, we get

$$\frac{\partial^2 u}{\partial \theta^2} + \frac{\partial^2 u}{\partial \phi^2} = 4xy \frac{\partial^2 u}{\partial x \partial y}$$

- Q.79** The Luminosity L of a star is connected with its mass M by the relation $L = a M (1 - \beta)$, where $0 < \beta < 1$ and $1 - \beta = b \beta^4 M^2$; a, b being given constants. If p is the percentage error made in the estimate of M , express the resulting percentage error in the calculated luminosity in terms of p and β and show that it lies between p and $3p$. (7)

Ans:

$$L = aM(1 - \beta) \quad , \quad 1 - \beta = b\beta^4 M^2$$

$$\Rightarrow \ln(L) = \ln(a) + \ln(M) + \ln(1 - \beta),$$

$$2 \ln(M) = \ln(1 - \beta) - \ln(b) - 4 \ln(\beta)$$

$$\Rightarrow \frac{\Delta L}{L} = \frac{\Delta M}{M} - \frac{\Delta \beta}{1 - \beta}, \quad (1) \text{ and}$$

$$2 \frac{\Delta M}{M} = - \frac{\Delta \beta}{1 - \beta} - 4 \frac{\Delta \beta}{\beta} = \frac{3\beta - 4}{\beta(1 - \beta)} \Delta \beta \quad (2)$$

Eliminating $\Delta \beta$ from (1) and (2), we get

$$\Rightarrow \frac{\Delta L}{L} = \frac{\beta - 4}{3\beta - 4} \frac{\Delta M}{M}$$

$$\text{Hence, } \frac{\Delta L}{L} \times 100 = \frac{\beta - 4}{3\beta - 4} p$$

is the required expression of percent change in L. Since $0 < \beta < 1$, we have

$$1 < \frac{\beta - 4}{3\beta - 4} < 3. \Rightarrow p < \frac{\Delta L}{L} \times 100 < 3p.$$

Q.80 Solve the following differential equations :

$$(i) \quad \frac{dy}{dx} + \frac{y}{x} \log y = \frac{y}{x^2} (\log y)^2. \quad (5)$$

$$(ii) \quad x^4 \frac{dy}{dx} + x^3 y = -\sec(xy). \quad (5)$$

Ans:

$$(i) \quad \frac{1}{y} \frac{dy}{dx} + \frac{1}{x} \log y = \frac{1}{x^2} (\log y)^2$$

$$\Rightarrow \frac{1}{y(\log y)^2} \frac{dy}{dx} + \frac{1}{x \log y} = \frac{1}{x^2}$$

$$\text{Let } \frac{1}{\log y} = t$$

$$\Rightarrow -\frac{1}{(\log y)^2} \cdot \frac{1}{y} \cdot \frac{dy}{dx} = \frac{dt}{dx}$$

$$\Rightarrow -\frac{dt}{dx} + \frac{t}{x} = \frac{1}{x^2}$$

$$\Rightarrow \frac{dt}{dx} - \frac{t}{x} = -\frac{1}{x^2}$$

$$\text{I.F. } e^{-\int \frac{1}{x} dx} = \frac{1}{x}$$

$$\therefore t \cdot \frac{1}{x} = -\int \frac{1}{x^2} \cdot \frac{1}{x} dx + c$$

$$\Rightarrow \frac{t}{x} = \frac{1}{2x^2} + c$$

$$\Rightarrow (x \log y)^{-1} = \frac{1}{2} x^{-2} + c$$

(ii) $x^4 \frac{dy}{dx} + x^3 y = -\sec(xy)$

$$x dy + y dx + \frac{\sec xy}{x^3} dx = 0$$

$$\Rightarrow \frac{d(xy)}{\sec xy} + \frac{dx}{x^3} = 0$$

Integrating,

$$2 \sin(xy) - \frac{1}{x^2} = c$$

Q.81 Change the order of integration in the following integral :

$$\int_0^{2a} \int_{\sqrt{2ax-x^2}}^{\sqrt{2ax}} f(x,y) dx dy \tag{4}$$

Ans:

$$I = \int_0^{2a} \int_{\sqrt{2ax-x^2}}^{\sqrt{2ax}} f(x,y) dx dy$$

This integration is first w.r.t. y and then w.r.t. x. On changing the order of integration, we first integrate w.r.t. x and then w.r.t. y. This divided into three regions.

Region I: The strip extends from parabola $y^2 = 2ax$ i.e. $x = \frac{y^2}{2a}$ to $x = 2a$.

Then $y = a$ to $y = 2a$

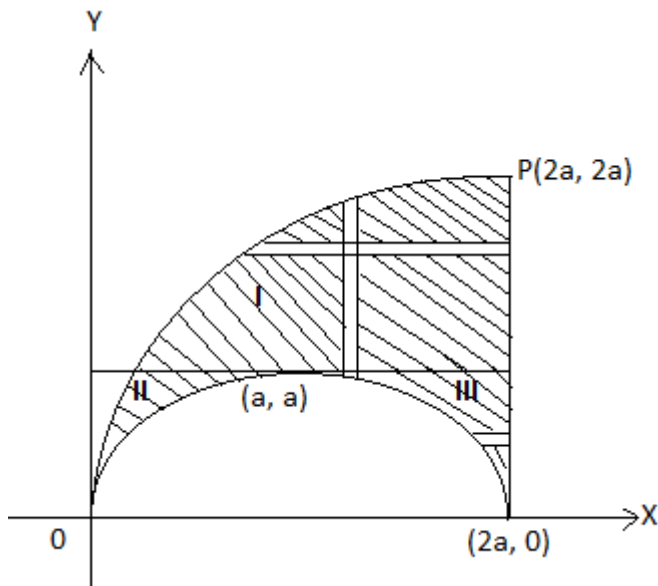

Region II: The strip extends from $x = \frac{y^2}{2a}$ to circle $x = a - \sqrt{a^2 - y^2}$.

Then $y = 0$ to a

Region III: The strip extends from circle, $x = a + \sqrt{a^2 - y^2}$ to $x = 2a$

Then $y = 0$ to $y = a$

$$\therefore I = \int_a^{2a} \int_{y^2/2a}^{2a} f(x, y) dx dy + \int_0^a \int_{y^2/2a}^{a - \sqrt{a^2 - y^2}} f(x, y) dx dy + \int_0^a \int_{a + \sqrt{a^2 - y^2}}^{2a} f(x, y) dx dy$$

Q.82 A string is stretched and fastened to two points at distance ℓ apart. Motion is ensued by displacing the string into the form $y = y_0 \sin \frac{\pi x}{\ell}$ from which it is released at time $t = 0$. Find the displacement at any point x and any time t . (5)

Ans:

The vibration of the string is given by

$$\frac{\partial^2 y}{\partial t^2} = c^2 \frac{\partial^2 y}{\partial x^2} \quad - \quad (i)$$

As the end points of the strings are fixed, for all time

$$y(0, t) = 0 = y(L, t) \quad - \quad (ii)$$

Since initial transverse velocity at any point of the string is zero.

$$\left(\frac{\partial y}{\partial t} \right)_{t=0} = 0 \quad - \quad (iii)$$

$$\text{Also, } y(x, 0) = y_0 \sin \frac{\pi x}{L} \quad - \quad (iv)$$

Using method of separation of variables and since the vibration of the string is periodic, therefore, the solution of (i) is of the form

$$y(x, t) = (c_1 \cos px + c_2 \sin px)(c_3 \cos cpt + c_4 \sin cpt) \quad - \quad (v)$$

By (ii), $y(0, t) = c_1 (c_3 \cos pct + c_4 \sin cpt) = 0$

This should be true if $c_1 = 0$

Hence $y(x, t) = c_2 \sin px (c_3 \cos cpt + c_4 \sin cpt)$ - (vi)

$$\frac{\partial y}{\partial t} = c_2 \sin px (-cp c_3 \sin cpt + cp c_4 \cos cpt)$$

By (iii) $\left(\frac{\partial y}{\partial t}\right)_{t=0} = c_2 \sin px c_4 cp = 0 \Rightarrow c_2 c_4 cp = 0$

If $c_2 = 0$, then (vi) will be $y(x, t) = 0$

$$\therefore C_4 = 0$$

Thus (vi) becomes

$$y(x, t) = c_2 c_3 \sin px \cos cpt, \quad \forall t$$

$$\text{By(ii)} \quad y(L, t) = c_2 c_3 \sin pL \cos cpt = 0, \quad \forall t$$

$$\because c_2, c_3 \neq 0, \quad \therefore \sin pL = 0$$

$$\therefore pL = n\pi$$

Hence (vi) reduces to

$$y(x, t) = c_2 c_3 \sin \frac{n\pi x}{L} \cos \frac{n\pi}{L} ct$$

From (iv) $y(x, 0) = c_2 c_3 \sin \frac{n\pi x}{L} = y_0 \sin \frac{\pi x}{L}$

$$\Rightarrow c_2 c_3 = y_0, \quad n = 1$$

$$\therefore \text{Solution is } y(x, t) = y_0 \sin \frac{\pi x}{L} \cos \frac{\pi ct}{L}$$

- Q.83** The ends A and B of an insulated rod of length ℓ , have their temperatures at 20°C and 80°C until steady state conditions prevail. The temperatures of these ends are changed suddenly to 40°C and 60°C respectively. Find the temperature distribution in the rod at any time t . (9)

Ans:

Let the equation for conduction of heat be

$$\frac{\partial u}{\partial t} = c^2 \frac{\partial^2 u}{\partial x^2} \quad - \quad (i)$$

Prior to temperature change at end B, when $t = 0$, the heat flow was independent of time (steady state condition), when u depends only on x i.e.

$$\frac{\partial^2 u}{\partial x^2} = 0 \quad \Rightarrow \quad u = ax + b$$

Since $u = 20$ for $x = 0$ and $u = 80$ for $x = L$

$$\therefore b = 20 \quad , \quad a = \frac{60}{L}$$

Thus initial condition is expressed as

$$u(x, 0) = \frac{60}{L}x + 20 \quad - \quad (ii)$$

The boundary conditions are

$$\left. \begin{array}{l} u(0, t) = 40 \\ u(L, t) = 60 \end{array} \right\} \quad \forall t \quad - \quad (iii)$$

The temperature function $u(x, t)$ can be written as

$$u(x, t) = u_s(x) + u_t(x, t) \quad - \quad (iv)$$

where $u_s(x)$ is a solution of (i) involving x only and satisfying boundary conditions (iii), which is steady state solution, $u_t(x, t)$ is a transient part of the solution which decreases with increase of t .

Since, $u_s(0) = 40$, $u_s(L) = 60$ \therefore using (ii), we get

$$u_s(x) = 40 + \frac{40}{L}x \quad - \quad (v)$$

From (iv), we get

$$\left. \begin{array}{l} u_t(0, t) = u(0, t) - u_s(0) = 40 - 40 = 0 \\ u_t(L, t) = u(L, t) - u_s(L) = 60 - 60 = 0 \end{array} \right\} \quad - \quad (vi)$$

$$\begin{aligned} \therefore u_t(x, 0) &= u(x, 0) - u_s(x) \\ &= \frac{60}{L}x + 20 - \left(40 + \frac{40}{L}x\right) \end{aligned}$$

$$\therefore u_t(x, 0) = \frac{20}{L}x - 20 \quad - \quad (vii)$$

General solution of (i) is given as

$$u_t(x, t) = (c_1 \cos px + c_2 \sin px) e^{-c^2 p^2 t}$$

$$u_t(0, t) = c_1 e^{-c^2 p^2 t} = 0 \quad \forall t \quad \Rightarrow \quad c_1 = 0$$

$$\therefore u_t(x,t) = c_2 \sin px e^{-c^2 p^2 t}$$

$$u_t(L,t) = c_2 \sin pL e^{-c^2 p^2 t} = 0 \quad \forall t$$

$$\Rightarrow \sin pL = 0 \quad \Rightarrow \quad pL = n\pi$$

$$u_t(x,t) = \sum_{n=1}^{\infty} b_n \sin \frac{n\pi}{L} x e^{-\frac{c^2 n^2 \pi^2 t}{L^2}}$$

$$u_t(x,0) = \sum b_n \sin \frac{n\pi}{L} x = \frac{20}{L} x - 20$$

$$\begin{aligned} \text{where } b_n &= \frac{2}{L} \int_0^L \left(\frac{20}{L} x - 20 \right) \sin \frac{n\pi}{L} x dx \\ &= -\frac{40}{n\pi} \end{aligned}$$

$$\therefore u_t(x,t) = \sum_{n=1}^{\infty} \left(-\frac{40}{n\pi} \right) \sin \frac{n\pi}{L} x e^{-\frac{c^2 n^2 \pi^2 t}{L^2}}$$

$$\therefore u(x,t) = 40 + \frac{40}{L} x - \frac{40}{\pi} \sum_{n=1}^{\infty} \frac{1}{n} \sin \frac{n\pi}{L} x e^{-\frac{c^2 n^2 \pi^2 t}{L^2}}$$

Q.84 Represent the function $f(z) = \frac{4z+4}{z(z-3)(z+2)}$ in Laurent's series

- (i) within $|z|=1$
- (ii) in the annular region within $|z|=2$ and $|z|=3$
- (iii) Exterior to $|z|=3$.

(8)

Ans:

$$f(z) = \frac{4(z+1)}{z(z-3)(z+2)} = \frac{A}{z} + \frac{B}{z-3} + \frac{C}{z+2}$$

$$\Rightarrow \quad A = -\frac{2}{3}, \quad B = \frac{16}{15}, \quad C = -\frac{2}{5}$$

$$f(z) = -\frac{2}{3} \cdot \frac{1}{z} + \frac{16}{15} \cdot \frac{1}{z-3} - \frac{2}{5} \cdot \frac{1}{z+2}$$

(i) $|z| < 1$

$$\begin{aligned}
 f(z) &= -\frac{2}{3z} + \frac{16}{15(-3)}\left(1 - \frac{z}{3}\right)^{-1} - \frac{2}{5(2)}\left(1 + \frac{z}{2}\right)^{-1} \\
 &= -\frac{2}{3z} - \frac{16}{45}\left(1 + \frac{z}{3} + \frac{z^2}{9} + \dots\right) - \frac{1}{5}\left(1 - \frac{z}{2} + \frac{z^2}{4} - \dots\right) \\
 &= \left(-\frac{2}{3z} - \frac{5}{9} - \frac{1}{54}z - \frac{29}{324}z^2 - \dots\right)
 \end{aligned}$$

(ii) $2 \leq |z| \leq 3$

$$\begin{aligned}
 f(z) &= -\frac{2}{3z} - \frac{16}{45}\left(1 - \frac{z}{3}\right)^{-1} - \frac{2}{5z}\left(1 + \frac{2}{z}\right)^{-1} \\
 &= -\frac{2}{3z} - \frac{16}{45}\left(1 + \frac{z}{3} + \frac{z^2}{9} + \dots\right) - \frac{2}{5z}\left(1 - \frac{2}{z} + \frac{4}{z^2} - \dots\right) \\
 f(z) &= \left[-\frac{8}{5z^3} + \frac{4}{5z^2} - \frac{16}{15z} - \frac{16}{45} - \frac{16}{135}z - \frac{16}{405}z^2 - \dots\right]
 \end{aligned}$$

(iii) $|z| > 3$

$$\begin{aligned}
 f(z) &= -\frac{2}{3z} + \frac{16}{15z}\left(1 - \frac{3}{z}\right)^{-1} - \frac{2}{5z}\left(1 + \frac{2}{z}\right)^{-1} \\
 &= -\frac{2}{3z} + \frac{16}{15z}\left(1 + \frac{3}{z} + \frac{9}{z^2} + \dots\right) - \frac{2}{5z}\left(1 - \frac{2}{z} + \frac{4}{z^2} - \dots\right) \\
 &= \frac{4}{z^2} + \frac{8}{z^3} + \dots
 \end{aligned}$$

Q.85 Apply the calculus of residue to evaluate $\int_{-\infty}^{\infty} \frac{x^2 - x + 2}{x^4 + 10x^2 + 9} dx$. (6)

Ans:

$$\int_{-\infty}^{\infty} \frac{x^2 - x + 2}{x^4 + 10x^2 + 9} dx$$

Let $f(z) = \frac{z^2 - z + 2}{z^4 + 10z^2 + 9} = \frac{z^2 - z + 2}{(z^2 + 9)(z^2 + 1)}$

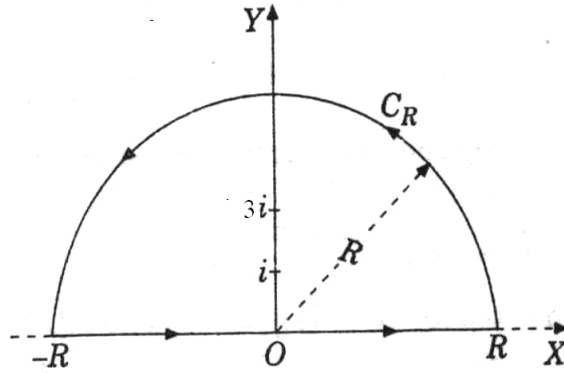

The pole of $f(z)$ enclosed by contour C , which consists of semicircle C_R and real axis segment from $-R$ to R taken in counter clockwise directions, are $z = i$, $z = 3i$ each of order 1.

$$\text{Residue at } z = i = \lim_{z \rightarrow i} \frac{(z-i)(z^2 - z + 2)}{(z-i)(z+i)(z^2 + 9)} = -\frac{(i+1)}{16}$$

$$\text{Residue at } z = 3i = \lim_{z \rightarrow 3i} \frac{(z-3i)(z^2 - z + 2)}{(z-3i)(z+3i)(z^2 + 1)} = \frac{3-7i}{48}$$

$$\therefore \int_C \frac{z^2 - z + 2}{(z^2 + 1)(z^2 + 9)} dz = 2\pi i \left[\frac{-i-1}{16} + \frac{3-7i}{48} \right] = \frac{5\pi}{12}$$

$$\therefore \int_{-R}^R \frac{x^2 - x + 2}{(x^2 + 1)(x^2 + 9)} dx + \int_{C_R} \frac{z^2 - z + 2}{(z^2 + 1)(z^2 + 9)} dz = \frac{5\pi}{12}$$

Let $R \rightarrow \infty$

$$\therefore \int_{-\infty}^{\infty} \frac{x^2 - x + 2}{(x^2 + 1)(x^2 + 9)} dx = \frac{5\pi}{12}, \text{ since second integral on the left hand side tends to 0.}$$

Q.86 Show that the stationary values of $u = \frac{x^2}{a^4} + \frac{y^2}{b^4} + \frac{z^2}{c^4}$, where $lx + my + nz = 0$ and

$$\frac{x^2}{a^2} + \frac{y^2}{b^2} + \frac{z^2}{c^2} = 1 \text{ are the roots of the equation } \frac{\ell^2 a^4}{1 - a^2 u} + \frac{m^2 b^4}{1 - b^2 u} + \frac{n^2 c^4}{1 - c^2 u} = 0. \quad (7)$$

Ans:

$$\text{Let } f = lx + my + nz, \quad g = \frac{x^2}{a^2} + \frac{y^2}{b^2} + \frac{z^2}{c^2} - 1$$

Let $F = u + \lambda_1 f + \lambda_2 g$ Using Lagrange's method of multiplier, for extreme values,

$$\frac{\partial f}{\partial x} = 0 = \frac{\partial f}{\partial y} = \frac{\partial f}{\partial z}, f = g = 0.$$

$$F = \frac{x^2}{a^4} + \frac{y^2}{b^4} + \frac{z^2}{c^4} + \lambda_1 (lx + my + nz) + \lambda_2 \left(\frac{x^2}{a^2} + \frac{y^2}{b^2} + \frac{z^2}{c^2} - 1 \right)$$

$$\Rightarrow \frac{2x}{a^4} + \lambda_1 l + \lambda_2 \frac{2x}{a^2} = 0 \quad (1)$$

$$\frac{2y}{b^4} + \lambda_1 m + \lambda_2 \frac{2y}{b^2} = 0 \quad (2)$$

$$\frac{2z}{c^4} + \lambda_1 n + \lambda_2 \frac{2z}{c^2} = 0 \quad (3)$$

$$lx + my + nz = 0 \quad (4)$$

$$\frac{x^2}{a^2} + \frac{y^2}{b^2} + \frac{z^2}{c^2} = 1 \quad (5)$$

Multiplying (1), (2), (3) by x, y, z respectively and adding, we get

$$2u + 2\lambda_2 = 0 \Rightarrow \lambda_2 = -u$$

$$\therefore x = -\frac{a^4 \lambda_1 l}{2(1 - a^2 u)}, \quad y = -\frac{b^4 \lambda_1 m}{2(1 - b^2 u)}, \quad z = -\frac{c^4 \lambda_1 n}{2(1 - c^2 u)}$$

Substituting in (4), we get

$$-\frac{\lambda_1}{2} \left[\frac{a^4 l^2}{1 - a^2 u} + \frac{b^4 m^2}{1 - b^2 u} + \frac{c^4 n^2}{1 - c^2 u} \right] = 0$$

$$\therefore \lambda_1 \neq 0 \quad \therefore \frac{a^4 l^2}{1 - a^2 u} + \frac{b^4 m^2}{1 - b^2 u} + \frac{c^4 n^2}{1 - c^2 u} = 0 \text{ is satisfied by stationary points.}$$

Q.87 Expand $f(x, y) = x^2 y + 3y - 2$ in powers of $(x - 1)$ and $(y + 2)$ upto 3rd degree terms. (7)

Ans:

$$f(x, y) = x^2 y + 3y - 2, \quad f(1, -2) = -10$$

$$\begin{aligned}
 f_x(x, y) &= 2xy & f_x(1, -2) &= -4 \\
 f_y(x, y) &= x^2 + 3 & f_y(1, -2) &= 4 \\
 f_{x^2}(x, y) &= 2y & f_{x^2}(1, -2) &= -4 \\
 f_{xy}(x, y) &= 2x & f_{xy}(1, -2) &= 2 \\
 f_{y^2}(x, y) &= 0 \\
 f_{x^3}(x, y) &= 0 & f_{xy^2}(x, y) &= 0 \\
 f_{x^2y}(x, y) &= 2 & f_{y^3}(x, y) &= 0
 \end{aligned}$$

$$\begin{aligned}
 f(x, y) &= f(1, -2) + [(x-1)f_x(1, -2) + (y+2)f_y(1, -2)] \\
 &+ \frac{1}{2} [(x-1)^2 f_{x^2}(1, -2) + 2(x-1)(y+2)f_{xy}(1, -2) + (y+2)^2 f_{y^2}(1, -2)] \\
 &+ \frac{1}{3} [(x-1)^3 f_{x^3}(1, -2) + 3(x-1)^2(y+2)f_{x^2y}(1, -2) \\
 &+ 3(x-1)(y+2)^2 f_{xy^2}(1, -2) + (y+2)^3 f_{y^3}(1, -2)] \\
 f(x, y) &= -10 - 4(x-1) + 4(y+2) - 2(x-1)^2 + 2(x-1)(y+2) + (x-1)^2(y+2)
 \end{aligned}$$

Q.88 A man takes a step forward with probability 0.4 and backward with probability 0.6. Find the probability that at the end of 11 steps, he is just one step away from the starting point. (7)

Ans:

Let us call a forward step “a success” and a backward step “a failure”.

Let X = no. of forward steps. Then X has binomial distribution with n = 11 and probability of success p = 0.4.

Required probability = P(X=6)+P(X=5)

$$= \binom{11}{5} (0.4)^5 (0.6)^6 + \binom{11}{6} (0.4)^6 (0.6)^5$$

Q.89 In a certain factory turning out razor blades, there is a small chance of $\frac{1}{500}$ for any blade to be defective. The blades are supplied in packets of 10. Using Poisson’s distribution calculate the approximate number of packets containing
 (i) no defective blade (ii) one defective blade (iii) two defectives blades

in a consignment of 10,000 packets $(e^{-0.02} = 0.9802)$. (7)

Ans:

$$p = \frac{1}{500} = 0.002, \quad n = 10$$

$$\therefore m = np = 0.02, \quad e^{-0.2} = 0.9802$$

- (i) Probability of no defective blade = $P(X=0)$
 $= e^{-m} = 0.9802$ (approximately)

$$\therefore \text{Mean number of packets containing no defective blade is}$$

$$= 10000 \times 0.9802 = 9802$$

- (ii) The mean number of packets containing one defective blade
 $= 10000 \times m e^{-m} = 196$

- (iii) The mean number of packets containing two defective blades
 $= 10000 \times \frac{m^2}{2} e^{-m}$
 $= 2$

Q.90 Show that at the point on the surface $x^x y^y z^z = C$, where $x = y = z$, we have

$$\frac{\partial^2 z}{\partial x \partial y} = \frac{-1}{x \log(ex)} \tag{7}$$

Ans:

It is given that $x^x y^y z^z = c$, taking log we get

$$x \log x + y \log y + z \log z = \log c$$

Differentiating the above equation w.r.t. y respectively, we get

$$\frac{\partial z}{\partial y} = -\frac{1 + \log y}{1 + \log z}, \text{ now differentiating w.r.t. } x \text{ we get}$$

$$\frac{\partial^2 z}{\partial x \partial y} = -(1 + \log y) \left(\frac{-1}{(1 + \log z)^2} \right) \frac{1}{z} \frac{\partial z}{\partial x} = - \left(\frac{(1 + \log y)(1 + \log x)}{(1 + \log z)^3} \right) \frac{1}{z}$$

At the point $x=y=z$, we get $\frac{\partial^2 z}{\partial x \partial y} = \left(\frac{-1}{x(\log ex)} \right)$

Q.91 Find the volume of greatest rectangular parallelopiped that can be inscribed inside the

ellipsoid $\frac{x^2}{a^2} + \frac{y^2}{b^2} + \frac{z^2}{c^2} = 1$. (7)

Ans:

Let edges of parallelopiped be $2x, 2y, 2z$ parallel to the coordinate axes. The volume V is given by $V = 8xyz$.

Let $\phi = \left[\frac{x^2}{a^2} + \frac{y^2}{b^2} + \frac{z^2}{c^2} - 1 \right]$ (1)

Using Lagrange’s multiplier method, for maxima and minima, let

$F = V + \phi \lambda$, where λ is a constant. For stationary values,

$$\frac{\partial F}{\partial x} = \frac{\partial F}{\partial y} = \frac{\partial F}{\partial z} = 0, \phi = 0$$

$$\Rightarrow 8yz + \frac{2x\lambda}{a^2} = 0$$

$$8xz + \frac{2y\lambda}{b^2} = 0$$

$$8yx + \frac{2z\lambda}{c^2} = 0$$

$$\Rightarrow \frac{x^2}{a^2} = \frac{y^2}{b^2} = \frac{z^2}{c^2}, \text{ substituting in } \frac{x^2}{a^2} + \frac{y^2}{b^2} + \frac{z^2}{c^2} = 1 \text{ gives } \frac{x^2}{a^2} = \frac{y^2}{b^2} = \frac{z^2}{c^2} = \frac{1}{3}$$

$$\Rightarrow x = \pm \frac{a}{\sqrt{3}}, y = \pm \frac{b}{\sqrt{3}}, z = \pm \frac{c}{\sqrt{3}} \text{ and } \text{Max.}V = \frac{8abc}{3\sqrt{3}}$$

Q.92 Change the order of integration and hence evaluate $\int_0^1 \int_x^{2-x} \frac{x}{y} dy dx$. (7)

Ans:

On changing order of integration, the elementary strip has to be taken parallel to x

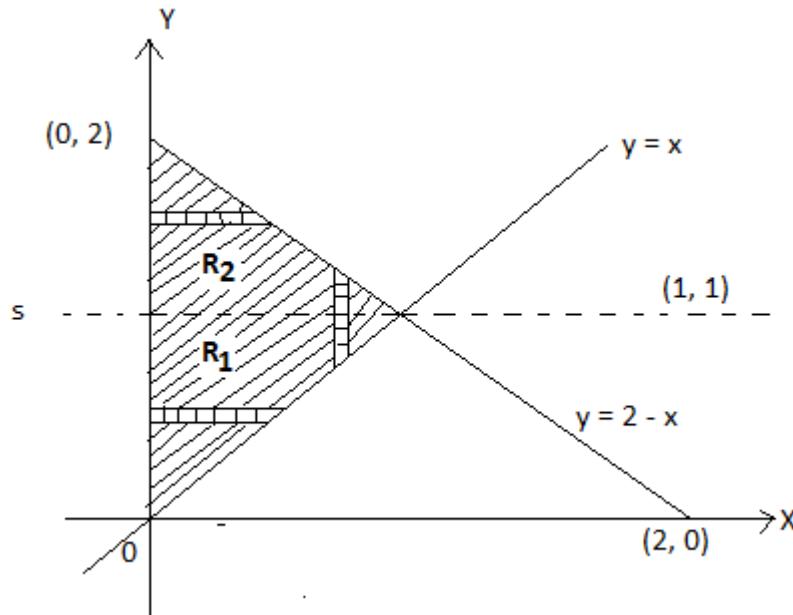

axis for which the region of integration has to be divided into two regions R_1 and R_2 . The region $R_1: 0 \leq x \leq y, 0 \leq y \leq 1$ and the region $R_2: 0 \leq x \leq 2-y, 1 \leq y \leq 2$.

$$\begin{aligned} \therefore I &= \int_0^1 \int_x^{2-x} \frac{x}{y} dx dy + \int_0^1 \int_0^y \frac{x}{y} dx dy + \int_1^2 \int_0^{2-y} \frac{x}{y} dx dy = \int_0^1 \left[\frac{x^2}{2y} \right]_x^{2-x} dy + \int_0^1 \left[\frac{x^2}{2y} \right]_0^y dy \\ &= \int_0^1 \frac{y}{2} dy + \int_1^2 \frac{(2-y)^2}{2y} dy = \left[\frac{y^2}{4} \right]_0^1 + \frac{1}{2} \left[4 \log y - 4y + \frac{y^2}{2} \right]_1^2 = 2 \log 2 - 1. \end{aligned}$$

Q.93 Find the volume common to cylinders $x^2 + y^2 = a^2$ and $x^2 + z^2 = a^2$. (7)

Ans:
The volume V is given as

$$\begin{aligned} \text{Volume} = V &= 8 \iiint_S dx dy dz = 8 \int_{x=0}^a \int_{y=0}^{\sqrt{a^2-x^2}} \int_{z=0}^{\sqrt{a^2-x^2}} dz dy dx \\ &= 8 \int_0^a \sqrt{a^2-x^2} \sqrt{a^2-x^2} dx = 8 \int_0^a (a^2-x^2) dx = \frac{16a^3}{3} \end{aligned}$$

Q.94 Solve the differential equations

(i) $(D^2 - 4D + 4)y = 8(x^2 + e^{2x} + \sin 2x)$. (8)

(ii) $\frac{dy}{dx} = -\frac{3y - 7x + 7}{7y - 3x + 3}$. (6)

Ans:
(i) The auxiliary equation is $m^2 - 4m + 4 = 0$, which gives $m = -2, -2$.

Thus C.F. is given as $(C_1 + C_2 x) e^{-2x}$.

$$\begin{aligned} P.I. &= \frac{1}{D^2 - 4D + 4} [8x^2 + 8 \sin 2x + 8e^{2x}] \\ &= 2 \left[1 - D + \frac{D^2}{4} \right]^{-1} x^2 + \frac{1}{D^2 - 4D + 4} [8 \sin 2x + 8e^{2x}] \\ &= I_1 + I_2 + I_3 \end{aligned}$$

$$I_1 = 2 \left[1 + D + \frac{3D^2}{4} + \dots \right] x^2 = 2 \left(x^2 + 2x + \frac{3}{2} \right)$$

$$I_2 = 8 \frac{1}{D^2 - 4D + 4} e^{2x}, \text{ since } 2 \text{ is a root of order } 2.$$

$$= 8 \frac{x^2}{\underline{2}} e^{2x} = 4x^2 e^{2x}$$

$$I_3 = 8 \frac{1}{D^2 - 4D + 4} \sin 2x = 8 \frac{1}{-4 - 4D + 4} \sin 2x = -2 \frac{1}{D} \sin 2x = \cos 2x$$

$$\therefore P.I. = 2x^2 + 4x + 3 + \cos 2x + 4x^2 e^{2x}$$

Therefore, general solution is

$$y = (c_1 + c_2 x)e^{-2x} + 2x^2 + 4x + 3 + 4x^2 e^{2x} + \cos 2x.$$

(ii) Let $Y = y + k$, $X = x + h$,

$$\therefore \frac{dy}{dx} = \frac{dY}{dX} = -\frac{3Y - 7X}{7Y - 3X}$$

where h, k are so chosen so that

$$-7h + 3k + 7 = 0$$

$$-3h + 7k + 3 = 0$$

Solving, we get $h = 1, k = 0$. Let $Y = VX$,

$$\therefore \frac{dY}{dX} = V + X \frac{dV}{dX} = -\frac{3V - 7}{7V - 3}$$

$$\Rightarrow X \frac{dV}{dX} = \frac{7(1 - V^2)}{7V - 3} \Rightarrow \frac{7dX}{X} - \frac{7V - 3}{(1 - V^2)} dV = 0$$

Integrating, we get

$$\log(X^7(V - 1)^2(V + 1)^5) = c \Rightarrow [y - x - 1]^2 [y + x + 1]^5 = k$$

Q.95 Discuss the consistency of the following system of equations for various values of λ

$$2x_1 - 3x_2 + 6x_3 - 5x_4 = 3$$

$$x_2 - 4x_3 + x_4 = 1$$

$$4x_1 - 5x_2 + 8x_3 - 9x_4 = \lambda$$

and, if consistent solve it.

(7)

Ans:

The augmented matrix is given as

$$(A : B) = \begin{bmatrix} 2 & -3 & 6 & -5 & : & 3 \\ 0 & 1 & -4 & 1 & : & 1 \\ 4 & -5 & 8 & -9 & : & \lambda \end{bmatrix}$$

Applying $R_3 \rightarrow R_3 - 2R_1$,

$$\left[\begin{array}{cccc|c} 2 & -3 & 6 & -5 & 3 \\ 0 & 1 & -4 & 1 & 1 \\ 0 & 1 & -4 & 1 & \lambda-6 \end{array} \right]$$

$$R_3 \rightarrow R_3 - R_1$$

$$\left[\begin{array}{cccc|c} 2 & -3 & 6 & -5 & 3 \\ 0 & 1 & -4 & 1 & 1 \\ 0 & 0 & 0 & 0 & \lambda-7 \end{array} \right]$$

If $\lambda \neq 7$, rank (A:B) = 3 \neq rank A = 2. Hence system is inconsistent.

If $\lambda = 7$, rank (A:B) = 2 = rank A . Hence system is consistent. The solution is obtained as follows :

Set $x_3 = t_1, x_4 = t_2, t_1, t_2$, arbitrary, then

$$x_2 = 4t_1 - t_2 + 1, \quad x_1 = 3t_1 + t_2 + 3.$$

Q.96 Find the characteristic equation of the matrix $A = \begin{bmatrix} 2 & 1 & 1 \\ 0 & 1 & 0 \\ 1 & 1 & 2 \end{bmatrix}$ and hence, find the matrix represented by $A^8 - 5A^7 + 7A^6 - 3A^5 + A^4 - 5A^3 + 8A^2 - 2A + I$. (7)

Ans:

The characteristic equation of A is $|A - \lambda I| = 0$

$$\Rightarrow \lambda^3 - 5\lambda^2 + 7\lambda - 3 = 0, \text{ is the characteristic equation.}$$

By Cayley Hamilton theorem, A must satisfy this equation i.e.

$$A^3 - 5A^2 + 7A - 3I = 0$$

$$\text{Thus } A^8 - 5A^7 + 7A^6 - 3A^5 + A^4 - 5A^3 + 8A^2 - 2A + I$$

$$= (A^5 + A)(A^3 - 5A^2 + 7A - 3I) + A^2 + A + I = A^2 + A + I$$

$$= \begin{pmatrix} 8 & 5 & 5 \\ 0 & 3 & 0 \\ 5 & 5 & 8 \end{pmatrix}$$

Q.97 Show that the vector field $\vec{F} = \frac{\vec{r}}{r^3}$ is irrotational as well as solenoidal. Find the scalar potential. (6)

Ans:

$$\begin{aligned}
 6(a) \quad \operatorname{div} \bar{F} &= \bar{\nabla} \cdot \left(\frac{\bar{r}}{r^3} \right) \\
 &= \frac{\partial}{\partial x} \left(\frac{x}{(x^2 + y^2 + z^2)^{3/2}} \right) + \frac{\partial}{\partial y} \left(\frac{y}{(x^2 + y^2 + z^2)^{3/2}} \right) + \frac{\partial}{\partial z} \left(\frac{z}{(x^2 + y^2 + z^2)^{3/2}} \right) \\
 &= \frac{3}{(x^2 + y^2 + z^2)^{3/2}} - \frac{3}{(x^2 + y^2 + z^2)^{5/2}} (x^2 + y^2 + z^2) = 0
 \end{aligned}$$

$\therefore \bar{\nabla} \cdot \bar{F} = 0 \therefore \bar{F}$ vector is solenoidal.

$$\begin{aligned}
 \operatorname{curl} \bar{F} &= \bar{\nabla} \times \bar{F} = \left(\sum \hat{i} \left(\frac{\partial}{\partial y} \left(\frac{z}{r^3} \right) - \frac{\partial}{\partial z} \left(\frac{y}{r^3} \right) \right) \right) \\
 &= \left(\sum \hat{i} \left(z \frac{\partial}{\partial y} \left(\frac{1}{r^3} \right) - y \frac{\partial}{\partial z} \left(\frac{1}{r^3} \right) \right) \right) = \left(\sum \hat{i} \left(z \left(\frac{-3y}{r^5} \right) + 3z \left(\frac{y}{r^5} \right) \right) \right) = 0
 \end{aligned}$$

Therefore \bar{F} is irrotational. Thus $\bar{F} = \bar{\nabla} \phi$, where ϕ is a scalar function.

$$\begin{aligned}
 \therefore \bar{F} = \bar{\nabla} \phi &\Rightarrow \bar{F} \cdot d\bar{r} = d\phi \Rightarrow d\phi = \frac{\bar{r} \cdot d\bar{r}}{r^3} = \frac{dr}{r^2} \\
 &\Rightarrow \phi = -\frac{1}{r} + c
 \end{aligned}$$

Q.98 Evaluate $\iint_S \bar{F} \cdot d\bar{s}$ where $\bar{F} = xy\hat{i} - x^2\hat{j} + (x+z)\hat{k}$ and S is the region of the plane $2x + 2y + z = 6$ in the first octant. (8)

Ans:

$$\iint_S \bar{F} \cdot \hat{n} ds = \iint_S \bar{F} \cdot d\bar{s}$$

Unit normal to the plane $2x + 2y + z = 6$ is along the vector $2\hat{i} + 2\hat{j} + \hat{k}$, is given as

$$\hat{n} = \frac{2\hat{i} + 2\hat{j} + \hat{k}}{3} \Rightarrow \bar{F} \cdot \hat{n} = \frac{2}{3}xy - \frac{2}{3}x^2 + \frac{1}{3}(x + 6 - 2x - 2y).$$

Thus projection of given plane $z=6-2x-2y$ on $z=0$ is region bounded by $x=0, y=0, y=3-x$.

$$\therefore \iint \bar{F} \cdot \hat{n} dS = \int_0^3 \int_0^{3-x} \left(\frac{2}{3}xy - \frac{2}{3}x^2 + \frac{1}{3}(x+6-2x-2y) \right) dy dx$$

$$\therefore \iint \bar{F} \cdot \hat{n} dS = \int_0^3 \left(\frac{1}{3}xy^2 - \frac{2}{3}x^2y + 2y - \frac{xy}{3} - \frac{y^2}{3} \right)_0^{3-x} dx$$

$$\therefore \iint \bar{F} \cdot \hat{n} dS = \int_0^3 (x^3 - 4x^2 + 2x + 3) dx = \left[\frac{x^4}{4} - \frac{4x^3}{3} + x^2 + 3x \right]_0^3 = \frac{9}{4}$$

Q.99 The odds that a Ph.D. thesis will be favourably reviewed by three independent examiners are 5 to 2, 4 to 3 and 3 to 4. What is the probability that a majority approve the thesis? (7)

Ans:

Let p_1, p_2, p_3 be the probabilities that thesis is approved by examiner A,B,C

$p_1 = 5/7, p_2 = 4/7, p_3 = 3/7$. A majority approves thesis if atleast two examiners are favorable.

$$P = p_1p_2q_3 + p_1p_3q_2 + p_2p_3q_1 + p_1p_2p_3$$

$$= \frac{5}{7} \frac{4}{7} \frac{4}{7} + \frac{5}{7} \frac{3}{7} \frac{3}{7} + \frac{4}{7} \frac{3}{7} \frac{2}{7} + \frac{5}{7} \frac{4}{7} \frac{3}{7} = 209/343.$$

Q.100 If the probabilities of committing an error of magnitude x is given by $y = \frac{h}{\sqrt{\pi}} e^{-h^2x^2}$, compute the probable error from the following data :
 $m_1 = 1.305, m_2 = 1.301, m_3 = 1.295, m_4 = 1.286, m_5 = 1.318, m_6 = 1.321, m_7 = 1.283,$
 $m_8 = 1.289, m_9 = 1.3, m_{10} = 1.286.$ (7)

Ans:

$$Mean = \frac{1}{10} \sum m_i = 1.2984, \sigma^2 = \frac{1}{10} \sum (m_i - mean)^2 = 0.0001594$$

$$\sigma = 0.0126,$$

We know that probable error is given as $(2/3)\sigma = 0.0084$.

Q.101 Solve by method of separation of variables $\frac{\partial^2 z}{\partial x^2} - 2 \frac{\partial z}{\partial x} + \frac{\partial z}{\partial y} = 0.$ (5)

Ans:

Let $Z=X(x)Y(y)$, then given differential equation becomes

$$X''Y - 2X'Y + XY' = 0, \text{ where } X'', Y', X', Y'' \text{ are first and second order derivatives.}$$

$$\Rightarrow \frac{X'' - 2X'}{X} = \frac{Y'}{Y} = a(\text{say})$$

$$\Rightarrow X'' - 2X' - aX = 0 \text{ and } Y' + aY = 0.$$

$$\therefore X = C_1 e^{(1+\sqrt{1+a})x} + C_2 e^{(1-\sqrt{1+a})x} \text{ and } Y = C_3 e^{-ay}$$

$$\therefore Z = e^{x-ay} (C_1 e^{\sqrt{1+a}x} + C_2 e^{-\sqrt{1+a}x})$$

Q.102 Solve $\frac{\partial u}{\partial t} = \alpha^2 \frac{\partial^2 u}{\partial x^2}$ for conduction of heat along a rod without radiation subject to

(i) u is not infinite for $t \rightarrow \infty$ (ii) $\frac{\partial u}{\partial x} = 0$ for $x = 0, x = \ell$

(iii) $u = \ell x - x^2$ for $t = 0$ between $x = 0$ and $x = \ell$. (9)

Ans:

Let $U = X(x)T(t)$, then given differential equation becomes

$$\Rightarrow \frac{X''}{X} = \frac{T'}{\alpha^2 T} = -k^2(\text{say})$$

$$\Rightarrow X = A \cos kx + B \sin kx \text{ and } T = C e^{-\alpha^2 k^2 t}. \text{ Condition (i) is satisfied.}$$

If $k^2 = 0, X = ax + b, T = c$, thus by condition (ii), we get $a = 0$

Thus $U = bc$.

$$\text{Now } U = (A \cos kx + B \sin kx) C e^{-\alpha^2 k^2 t}$$

By (ii) condition, we get $B = 0, kl = n\pi$. Thus

$$C e^{-\alpha^2 \frac{n^2 \pi^2}{l^2} t} \cos \frac{\pi n}{l} x \text{ is solution for all } n.$$

$$\therefore U = a_0 + \sum_{n=0}^{\infty} a_n e^{-\alpha^2 \frac{n^2 \pi^2}{l^2} t} \cos \frac{\pi n}{l} x$$

$$\text{Since } lx - x^2 = U = a_0 + \sum_{n=0}^{\infty} a_n \cos \frac{\pi n}{l} x$$

$$a_0 = \frac{1}{l} \int_0^l (lx - x^2) dx = \frac{l^2}{6}$$

$$a_n = \frac{2}{l} \int_0^l (lx - x^2) \cos \frac{n\pi}{l} x dx = \begin{cases} -\frac{4l^2}{\pi^2 n^2} & \text{if } n \text{ is even} \\ 0 & \text{otherwise} \end{cases}$$

$$\therefore U = \frac{l^2}{16} - \frac{l^2}{\pi^2} \sum_{m=1}^{\infty} \frac{1}{m^2} e^{-\alpha^2 \frac{4m^2 \pi^2 t}{l^2}} \cos \frac{\pi 2m}{l} x$$

Q.103 Obtain the series solution of equation $x(1-x)\frac{d^2y}{dx^2} - (1+3x)\frac{dy}{dx} - y = 0$. (8)

Ans:

Since $x = 0$ is a regular singular point

Let $y(x) = \sum_{m=0}^{\infty} C_m x^{m+r}$, $C_0 \neq 0$

$$y' = \sum_{m=0}^{\infty} C_m (m+r) x^{m+r-1}$$

$$y'' = \sum_{m=0}^{\infty} C_m (m+r)(m+r-1) x^{m+r-2}$$

Now the given differential equation becomes

$$\sum_{m=0}^{\infty} [C_m (m+r)(m+r-1)(1-x)x^{m+r-1} - C_m (m+r)(1+3x)x^{m+r-1} - C_m x^{m+r}] = 0$$

The terms with lowest power of x is x^{r-1} . Its coefficient equated to zero gives $C_0 r(r-2) = 0$.

Because $C_0 \neq 0$

$$\Rightarrow r = 0, \quad r = 2$$

The coefficient of x^{m+r} is equated to zero gives

$$C_1 = \frac{r+1}{r-1} C_0, \quad C_2 = \frac{r+1}{r-1} \frac{r+2}{r} C_0, \dots$$

$$\therefore y = a_0 x^r \left[1 + \frac{r+1}{r-1} x + \frac{r+1}{r-1} \frac{r+2}{r} x^2 + \dots \right]$$

Let $a_0 = b_0 r$, $\therefore y_1 = b_0 x^r \left[r + r \frac{r+1}{r-1} x + \frac{r+1}{r-1} (r+2) x^2 + \dots \right]$

Now $\frac{\partial y_1}{\partial r}$ gives $y_2 = (y_1)_{r=0} \log x + b_0 [1 - x - 5x^2 + \dots]$

$$\therefore y = (c_1 + c_2 \log x) [1.2x^2 + 3.2x^3 + \dots] + c_2 [-1 + x + 5x^2 + \dots]$$

Q.104 Express $J_5(x)$ in terms of $J_0(x)$ and $J_1(x)$. (6)

Ans:

We know

$$J_n(x) = \frac{x}{2n}(J_{n-1} + J_{n+1}) \Rightarrow J_{n+1}(x) = \frac{2n}{x}J_n - J_{n-1}$$

For n = 1, 2, 3

$$J_2(x) = \frac{2}{x}J_1 - J_0$$

$$J_3(x) = \frac{4}{x}J_2 - J_1$$

$$J_4(x) = \frac{6}{x}J_3(x) - J_2$$

$$J_5(x) = \frac{8}{x}J_4(x) - J_3$$

$$J_5(x) = \left(\frac{384}{x^3} - \frac{8}{x}\right)J_1(x) + \left(\frac{-192}{x^3} + \frac{12}{x}\right)J_0(x)$$

Q.105 Express f(x) as $= \frac{1}{4}P_0(x) + \frac{1}{2}P_1(x) + \frac{5}{16}P_2(x)$ where $f(x) = \begin{cases} 0, & -1 < x \leq 0 \\ x, & 0 < x < 1 \end{cases}$. (7)

Ans:

If $f(x) = \sum c_n P_n(x)$, then

$$c_n = \left(n + \frac{1}{2}\right) \int_{-1}^1 P_n f(x) dx = \left(n + \frac{1}{2}\right) \left[\int_{-1}^0 P_n \cdot 0 dx + \int_0^1 P_n x dx \right]$$

$$\therefore c_0 = \frac{1}{4} \quad c_1 = \frac{1}{2} \quad c_2 = \frac{5}{16}, \dots$$

where we have used the fact that $P_0(x) = 1$, $P_1(x) = x$, $P_2(x) = \frac{1}{2}(3x^2 - 1)$

$$\therefore f(x) = \frac{1}{4}P_0 + \frac{1}{2}P_1 + \frac{5}{16}P_2 + \dots$$

Q.106 Find analytic function whose real part is $\frac{\sin 2x}{\cosh 2y - \cos 2x}$. (7)

Ans:

Let $u = \frac{\sin 2x}{\cosh 2y - \cos 2x}$, and $f(z) = u + iv$

$$\frac{\partial u}{\partial x} = \frac{(\cosh 2y - \cos 2x) 2 \cos 2x - 2 \sin^2 2x}{(\cosh 2y - \cos 2x)^2}$$

$$\frac{\partial u}{\partial y} = \frac{2 \sin 2x \sinh 2y}{(\cosh 2y - \cos 2x)^2}$$

$$f'(z) = \frac{\partial u}{\partial x} + i \frac{\partial v}{\partial x} = \frac{\partial u}{\partial x} - i \frac{\partial u}{\partial y} \quad \text{since } u \text{ is an analytic function, thus it must satisfies}$$

C-R equations, thus $\frac{\partial v}{\partial x} = -\frac{\partial u}{\partial y}$

$$f'(z) = \frac{(\cosh 2y - \cos 2x) 2 \cos 2x - 2 \sin^2 2x + i 2 \sin 2x \sinh 2y}{(\cosh 2y - \cos 2x)^2}$$

Using Milne's Thomson method, Let $x = z, y = 0$

$$f'(z) = \frac{2(\cos 2z - 1)}{(1 - \cos 2z)^2} = \frac{-2}{1 - \cos 2z} = -\operatorname{cosec}^2 z$$

$\therefore f(z) = \cot z + c$, where c is an arbitrary constant.

Q.107 Show that under the transformation $w = \frac{z-i}{z+i}$, real axis in the z -plane is mapped into the circle $|w|=1$. Which portion of the z plane corresponds to the interior of the circle?
(7)

Ans:

$$|w| = \left| \frac{z-i}{z+i} \right| = \left| \frac{x+i(y-1)}{x+i(y+1)} \right| = \sqrt{\frac{x^2 + (y-1)^2}{x^2 + (y+1)^2}}$$

For the real axis in the z plane $y=0$, i.e. $|w|=1$, Also $|w|<1$ implies $y>0$. hence the result.

Q.108 Let $F(\xi) = \int_C \frac{4z^2 + z + 5}{z - \xi} dz$ where C is ellipse $\left(\frac{x}{2}\right)^2 + \left(\frac{y}{3}\right)^2 = 1$. Find value of $F(3.5)$ and $F'(-1)$.
(7)

Ans:

$$F(3.5) = \int_C \frac{4z^2 + z + 5}{z - 3.5} dz, \text{ since } 3.5 \text{ is a point which lies outside } C, \text{ thus } F(3.5) = 0 \text{ by Cauchy}$$

theorem.

Also -1 lies within C, by Cauchy Integral Formula

$$\int_C \frac{4z^2 + z + 5}{z - \xi} dz = 2\pi i(4\xi^2 + \xi + 5) = F(\xi)$$

$$F'(\xi) = 2\pi i(8\xi + 5), \quad F'(-1) = -6\pi i.$$

Q.109 Compute $f_{xy}(0,0)$ and $f_{yx}(0,0)$ for the function

$$f(x, y) = \begin{cases} \frac{xy^3}{x + y^2}, & (x, y) \neq (0,0) \\ 0 & , (x, y) = (0,0) \end{cases} \tag{6}$$

Ans:

$$f_x(0,0) = \lim_{x \rightarrow 0} \frac{f(x,0) - f(0,0)}{x} = 0$$

$$f_y(0,0) = \lim_{y \rightarrow 0} \frac{f(0,y) - f(0,0)}{y} = 0$$

$$f_x(0,y) = \lim_{x \rightarrow 0} \frac{f(x,y) - f(0,y)}{x} = \lim_{x \rightarrow 0} \frac{xy^3 - 0}{x(x + y^2)} = y$$

$$f_y(x,0) = \lim_{y \rightarrow 0} \frac{f(x,y) - f(x,0)}{y} = \lim_{y \rightarrow 0} \frac{xy^3}{y(x + y^2)} = 0$$

$$f_{xy}(0,0) = \lim_{x \rightarrow 0} \frac{f_y(x,0) - f_y(0,0)}{x} = 0$$

$$f_{yx}(0,0) = \lim_{y \rightarrow 0} \frac{f_x(0,y) - f_x(0,0)}{y} = \lim_{y \rightarrow 0} \frac{y}{y} = 1$$

Q.110 Let v be a function of (x, y) and x, y are functions of (θ, ϕ) defined by

$$x + y = 2e^\theta \cos \phi$$

$$x - y = 2ie^\theta \sin \phi$$

$$\text{where } i = \sqrt{-1}. \text{ Show that } x \frac{\partial v}{\partial x} + y \frac{\partial v}{\partial y} = \frac{\partial v}{\partial \theta}. \tag{8}$$

Ans:

$$\text{Because } x + y = 2e^\theta \cos \phi, \quad x - y = 2ie^\theta \sin \phi$$

Adding & Subtracting, we get

$$2x = 2e^{\theta} (\cos\phi + i\sin\phi) = 2e^{\theta + i\phi}$$

$$\Rightarrow x = e^{\theta + i\phi}$$

Similarly $y = e^{\theta - i\phi}$

Let $v = f(x, y), \quad x = g(\theta, \phi), \quad y = h(\theta, \phi)$

$$\begin{aligned} \frac{\partial v}{\partial \theta} &= \frac{\partial v}{\partial x} \cdot \frac{\partial x}{\partial \theta} + \frac{\partial v}{\partial y} \cdot \frac{\partial y}{\partial \theta} \\ &= \frac{\partial v}{\partial x} (e^{\theta + i\phi}) + \frac{\partial v}{\partial y} (e^{\theta - i\phi}) \\ &= x \cdot \frac{\partial v}{\partial x} + y \cdot \frac{\partial v}{\partial y} \end{aligned}$$

Q.111 Expand x^y near (1, 1) upto 3rd degree terms by Taylor's series. (7)

Ans:

$$f(x, y) = x^y, \quad f(1, 1) = 1$$

$$f_x(x, y) = yx^{y-1}, \quad f_x(1, 1) = 1$$

$$f_y(x, y) = x^y \log x, \quad f_y(1, 1) = 0$$

$$f_{x^2}(x, y) = y(y-1)x^{y-2}, \quad f_{x^2}(1, 1) = 0$$

$$f_{y^2}(x, y) = x^y (\log x)^2, \quad f_{y^2}(1, 1) = 0$$

$$f_{xy}(x, y) = x^{y-1} + yx^{y-1} \log x, \quad f_{xy}(1, 1) = 1$$

$$f_{x^3}(x, y) = y(y-1)(y-2)x^{y-3}, \quad f_{x^3}(1, 1) = 0$$

$$f_{x^2y}(x, y) = (2y-1)x^{y-2} + y(y-1)x^{y-2} \log x, \quad f_{x^2y}(1, 1) = 1$$

$$f_{xy^2}(x, y) = yx^{y-1} (\log x)^2 + 2 \log x x^{y-1}, \quad f_{xy^2}(1, 1) = 0$$

$$f_{y^3}(x, y) = x^y (\log x)^3, \quad f_{y^3}(1, 1) = 0$$

By Taylor's Theorem

$$\begin{aligned}
 f(x, y) &= f(1,1) + \frac{1}{1!}[(x-1) f_x(1,1) + (y-1) f_y(1,1)] \\
 &\quad + \frac{1}{2!}[(x-1)^2 f_{x^2}(1,1) + 2(x-1)(y-1) f_{xy}(1,1) + (y-1)^2 f_{y^2}(1,1)] \\
 &\quad + \frac{1}{3!}[(x-1)^3 f_{x^3}(1,1) + 3(x-1)^2(y-1) f_{x^2y}(1,1) \\
 &\quad + 3(x-1)(y-1)^2 f_{xy^2}(1,1) + (y-1)^3 f_{y^3}(1,1)] + \dots \\
 x^y &= 1 + (x-1) + (x-1)(y-1) + \frac{1}{2}(x-1)^2(y-1)
 \end{aligned}$$

Q.112 Find the extreme value of $x^2 + y^2 + z^2 + xy + xz + yz$ subject to the conditions $x + y + z = 1$ and $x + 2y + 3z = 3$. (7)

Ans:

Let $f = x^2 + y^2 + z^2 + xy + xz + zy$
 $g = x + y + z - 1 = 0$
 $h = x + 2y + 3z - 3 = 0$

Let λ_1, λ_2 be two constants. Using Lagrange’s multiplier method, we get

$F = f + \lambda_1 g + \lambda_2 h$ OR

$F = x^2 + y^2 + z^2 + xy + xz + zy + \lambda_1(x + y + z - 1) + \lambda_2(x + 2y + 3z - 3)$

For extreme values,

$\frac{\partial F}{\partial x} = 0 = \frac{\partial F}{\partial y} = \frac{\partial F}{\partial z}, \quad x + y + z = 1, \quad x + 2y + 3z = 3.$

$$\begin{aligned}
 \Rightarrow \quad 2x + y + z + \lambda_1 + \lambda_2 &= 0 & \Rightarrow \quad x + \lambda_1 + \lambda_2 + 1 &= 0 \\
 2y + x + z + \lambda_1 + 2\lambda_2 &= 0 & y + \lambda_1 + 2\lambda_2 + 1 &= 0 \\
 2z + x + y + \lambda_1 + 3\lambda_2 &= 0 & z + \lambda_1 + 3\lambda_2 + 1 &= 0
 \end{aligned} \quad \left. \vphantom{\begin{aligned} \Rightarrow \quad 2x + y + z + \lambda_1 + \lambda_2 &= 0 \\ 2y + x + z + \lambda_1 + 2\lambda_2 &= 0 \\ 2z + x + y + \lambda_1 + 3\lambda_2 &= 0 \end{aligned}} \right\} (A)$$

Adding (A) and using $x + y + z = 1$, we get

$3\lambda_1 + 6\lambda_2 + 4 = 0$

Multiplying equation (ii) of ‘A’ by 2 and (iii) by 3 and adding all and using

$x + 2y + 3z = 1$, we get $6\lambda_1 + 14\lambda_2 + 9 = 0$

Solving, $3\lambda_1 + 6\lambda_2 + 4 = 0$

$6\lambda_1 + 14\lambda_2 + 9 = 0$, we get

$\lambda_1 = -1/3, \quad \lambda_2 = -1/2$

From (A), we get

$$x = -1/6, \quad y = 1/3, \quad z = 5/6$$

Therefore, $(-1/6, 1/3, 5/6)$ is a point of extremum, with extreme value

$$F(-1/6, 1/3, 5/6) = (-1/6)^2 + (1/3)^2 + (5/6)^2 - 1/6 * 1/3 - 1/6 * 5/6 + 1/3 * 5/6 = 11/12$$

Q.113 Find the rank of the matrix

$$\begin{bmatrix} 9 & 3 & 1 & 0 \\ 3 & 0 & 1 & -6 \\ 1 & 1 & 1 & 1 \\ 0 & -6 & 1 & 9 \end{bmatrix} \tag{6}$$

Ans:

Applying $R_1 \leftrightarrow R_3, \quad R_2 \leftrightarrow R_4$

$$A = \begin{bmatrix} 1 & 1 & 1 & 1 \\ 0 & -6 & 1 & 9 \\ 9 & 3 & 1 & 0 \\ 3 & 0 & 1 & -6 \end{bmatrix}$$

$R_3 \leftrightarrow R_4$

$$A = \begin{bmatrix} 1 & 1 & 1 & 1 \\ 0 & -6 & 1 & 9 \\ 3 & 0 & 1 & -6 \\ 9 & 3 & 1 & 0 \end{bmatrix}$$

$R_3 \rightarrow R_3 - 3R_1, \quad R_4 \rightarrow R_4 - 9R_1$

$$A = \begin{bmatrix} 1 & 1 & 1 & 1 \\ 0 & -6 & 1 & 9 \\ 0 & -3 & -2 & -9 \\ 0 & -6 & -8 & -9 \end{bmatrix}$$

$R_4 \rightarrow R_4 - R_2, \quad R_3 \rightarrow R_2 - 2R_3$

$$A = \begin{bmatrix} 1 & 1 & 1 & 1 \\ 0 & -6 & 1 & 9 \\ 0 & 0 & 5 & 27 \\ 0 & 0 & -9 & -18 \end{bmatrix}$$

$R_4 \rightarrow 9R_3 + 5R_4$

$$A = \begin{bmatrix} 1 & 1 & 1 & 1 \\ 0 & -6 & 1 & 9 \\ 0 & 0 & 5 & 27 \\ 0 & 0 & 0 & 153 \end{bmatrix}$$

Thus $|A| \neq 0$ Hence, rank of $A = 4$.

Q.114 Let $y_1 = 5x_1 + 3x_2 + 3x_3$
 $y_2 = 3x_1 + 2x_2 - 2x_3$
 $y_3 = 2x_1 - x_2 + 2x_3$

be a linear transformation from (x_1, x_2, x_3) to (y_1, y_2, y_3) and

$$z_1 = 4x_1 + 2x_3$$

$$z_2 = x_2 + 4x_3$$

$$z_3 = 5x_3,$$

be a linear transformation from (x_1, x_2, x_3) to (z_1, z_2, z_3) .

Find the linear transformation from (z_1, z_2, z_3) to (y_1, y_2, y_3) by inverting appropriate matrix and matrix multiplication. (8)

Ans:

Let

$$\begin{bmatrix} y_1 \\ y_2 \\ y_3 \end{bmatrix} = \begin{bmatrix} 5 & 3 & 3 \\ 3 & 2 & -2 \\ 2 & -1 & 2 \end{bmatrix} \begin{bmatrix} x_1 \\ x_2 \\ x_3 \end{bmatrix}$$

$$\begin{bmatrix} z_1 \\ z_2 \\ z_3 \end{bmatrix} = \begin{bmatrix} 4 & 0 & 2 \\ 0 & 1 & 4 \\ 0 & 0 & 5 \end{bmatrix} \begin{bmatrix} x_1 \\ x_2 \\ x_3 \end{bmatrix}$$

$$\begin{bmatrix} y_1 \\ y_2 \\ y_3 \end{bmatrix} = \begin{bmatrix} 5 & 3 & 3 \\ 3 & 2 & -2 \\ 2 & -1 & 2 \end{bmatrix} \begin{bmatrix} 4 & 0 & 2 \\ 0 & 1 & 4 \\ 0 & 0 & 5 \end{bmatrix}^{-1} \begin{bmatrix} z_1 \\ z_2 \\ z_3 \end{bmatrix}$$

$$= \frac{1}{20} \begin{bmatrix} 5 & 3 & 3 \\ 3 & 2 & -2 \\ 2 & -1 & 2 \end{bmatrix} \begin{bmatrix} 5 & 0 & -2 \\ 0 & 20 & -16 \\ 0 & 0 & 4 \end{bmatrix} \begin{bmatrix} z_1 \\ z_2 \\ z_3 \end{bmatrix}$$

$$= \frac{1}{20} \begin{bmatrix} 25 & 60 & -46 \\ 15 & 40 & -46 \\ 10 & -20 & 20 \end{bmatrix} \begin{bmatrix} z_1 \\ z_2 \\ z_3 \end{bmatrix}$$

$$= \begin{bmatrix} 1.25 & 3 & -2.3 \\ 0.75 & 2 & -2.3 \\ 0.5 & -1 & 1 \end{bmatrix} \begin{bmatrix} z_1 \\ z_2 \\ z_3 \end{bmatrix}$$

$$y_1 = 1.25 z_1 + 3 z_2 - 2.3 z_3$$

$$y_2 = 0.75 z_1 + 2 z_2 - 2.3 z_3$$

$$y_3 = 0.5 z_1 - z_2 + z_3$$

Q.115 Prove that the eigenvalues of a real matrix are real or complex conjugates in pairs and further if the matrix is orthogonal, then eigenvalues have absolute value 1. (6)

Ans:

Let A be a square matrix of order n.

$$\text{Then } |A - \lambda I| = (-1)^n \lambda^n + k_1 \lambda^{n-2} + \dots + k_n = 0$$

where k's are expressible in terms of elements a_{ij} of matrix A. The roots of this equation are eigen values of matrix A. Since this is n^{th} polynomial in λ which has n distinct roots which are either real or complex conjugates.

Hence, eigen values of matrix are either real or complex conjugates.

If λ is an eigen value of orthogonal matrix then $1/\lambda$ is an eigen value of A^{-1} . Because A is an orthogonal matrix. Therefore A^{-1} is same as A' .

Therefore $1/\lambda$ is eigen value of A' . But A and A' have same eigen values.

Hence, $1/\lambda$ is also an eigen value of A. The product of eigen value of orthogonal matrix = 1 and hence if the order of A is odd it must have 1 as eigen value. Since product of eigen value of matrix A is equal to its determinant. Therefore $|A| = \pm 1$.

Q.116 Find eigenvalues and eigenvectors of the matrix $A = \begin{bmatrix} -2 & 2 & -3 \\ 2 & 1 & -6 \\ -1 & -2 & 0 \end{bmatrix}$. (8)

Ans:

$$|A - \lambda I| = 0$$

$$\Rightarrow \begin{vmatrix} -2-\lambda & 2 & -3 \\ 2 & 1-\lambda & -6 \\ -1 & -2 & -\lambda \end{vmatrix} = 0$$

$$\Rightarrow \lambda^3 + \lambda^2 - 21\lambda - 45 = 0$$

$$\Rightarrow \lambda = 5, -3, -3$$

Eigen values are 5, -3, -3

For $\lambda = 5$, eigen vectors are obtained from

$$\begin{vmatrix} -7 & 2 & -3 \\ 2 & -4 & -6 \\ -1 & -2 & -5 \end{vmatrix} \begin{vmatrix} x \\ y \\ z \end{vmatrix} = \begin{vmatrix} 0 \\ 0 \\ 0 \end{vmatrix}$$

$$\Rightarrow -7x + 2y - 3z = 0$$

$$2x - 4y - 6z = 0$$

$$-x - 2y - 5z = 0$$

Solving we get, $\frac{x}{-1} = \frac{y}{-2} = \frac{z}{1}$

i.e. $(1, 2, -1)'$ is an eigen vector

For $\lambda = -3$, eigen vectors are obtained from

$$\begin{vmatrix} 1 & 2 & -3 \\ 2 & 4 & -6 \\ -1 & -2 & 3 \end{vmatrix} \begin{vmatrix} x \\ y \\ z \end{vmatrix} = \begin{vmatrix} 0 \\ 0 \\ 0 \end{vmatrix}$$

i.e. $x + 2y - 3z = 0$

There are two linearly independent eigen vectors for $\lambda = -3$. These are obtained by putting $x = 0$ and $y = 0$ respectively in the equation.

Let $x = 0$ then $2y - 3z = 0$

i.e. $\begin{vmatrix} 0 \\ 3 \\ 2 \end{vmatrix}$ is an eigen vector

Let $y = 0$, then $x - 3z = 0$

$\begin{vmatrix} 3 \\ 0 \\ 1 \end{vmatrix}$ is an eigen vector.

Eigen vectors corresponding to 5, -3, -3 are

$[1, 2, -1]'$, $[0, 3, 2]'$ and $[3, 0, 1]'$.

Q.117 Find a matrix X such that $X^{-1}AX$ is a diagonal matrix, where $A = \begin{bmatrix} 5 & 4 \\ 1 & 2 \end{bmatrix}$. Hence compute A^{50} . (8)

Ans:

$$A = \begin{bmatrix} 5 & 4 \\ 1 & 2 \end{bmatrix}$$

$$|A - \lambda I| = 0$$

$$\Rightarrow \lambda^2 - 7\lambda + 6 = 0$$

$$\Rightarrow \lambda = 1, 6$$

For $\lambda = 1$,

$$\begin{bmatrix} 4 & 4 \\ 1 & 1 \end{bmatrix} \begin{bmatrix} x \\ y \end{bmatrix} = 0$$

Therefore, $x + y = 0$

Eigen vector is $(1, -1)'$

For $\lambda = 6$,

$$\begin{bmatrix} -1 & 4 \\ 1 & -4 \end{bmatrix} \begin{bmatrix} x \\ y \end{bmatrix} = 0$$

Therefore, $x - 4y = 0$

Eigen vector is $(4, 1)'$

Therefore, modal matrix is $X = \begin{bmatrix} 1 & 4 \\ -1 & 1 \end{bmatrix}$ and

$$X^{-1} = \frac{1}{5} \begin{bmatrix} 1 & -4 \\ 1 & 1 \end{bmatrix}$$

$$D = X^{-1}AX = \frac{1}{5} \begin{bmatrix} 1 & -4 \\ 1 & 1 \end{bmatrix} \begin{bmatrix} 5 & 4 \\ 1 & 2 \end{bmatrix} \begin{bmatrix} 1 & 4 \\ -1 & 1 \end{bmatrix} = \begin{bmatrix} 1 & 0 \\ 0 & 6 \end{bmatrix} \text{ which is diagonal matrix}$$

Also $A = XDX^{-1}$

$$A^{50} = XD^{50}X^{-1}$$

$$= X \begin{bmatrix} 1 & 0 \\ 0 & 6^{50} \end{bmatrix} X^{-1}$$

Q.118 Prove that a general solution of the system

$$8x_1 - 4x_2 + 10x_5 = 1$$

$$x_2 + x_4 - x_5 = 2$$

$$x_3 - 3x_4 + 2x_5 = 0$$

can be written as

$$(x_1, x_2, x_3, x_4, x_5) = \left(\frac{9}{8}, 2, 0, 0, 0\right) + \alpha\left(-\frac{1}{2}, -1, 3, 1, 0\right) + \beta\left(-\frac{3}{4}, 1, -2, 0, 1\right) \text{ where } \alpha, \beta \text{ are arbitrary.} \tag{6}$$

Ans:

The system of equation can be written as $AX = B$

$$A = \begin{bmatrix} 8 & -4 & 0 & 0 & 10 \\ 0 & 1 & 0 & 1 & -1 \\ 0 & 0 & 1 & -3 & 2 \end{bmatrix}, X = \begin{bmatrix} x_1 \\ x_2 \\ x_3 \\ x_4 \\ x_5 \end{bmatrix}, B = \begin{pmatrix} 1 \\ 2 \\ 0 \end{pmatrix}$$

$\text{Rank}(A) = \text{Rank}(A, B) = 3$. Thus system is consistent. Homogeneous system $AX=0$, has $5 - 3 = 2$ linearly independent solutions. Clearly $(-\frac{1}{2}, -1, 3, 1, 0), (-\frac{3}{4}, 1, -2, 0, 1)$ are linearly

independent and satisfy the homogeneous system $AX = 0$. Also $(\frac{9}{8}, 2, 0, 0, 0)$ is a particular solution of non-homogeneous system $AX = B$. Thus general solution of non homogeneous system is $(x_1, x_2, x_3, x_4, x_5) = (\frac{9}{8}, 2, 0, 0, 0) + \alpha(-\frac{1}{2}, -1, 3, 1, 0) + \beta(-\frac{3}{4}, 1, -2, 0, 1)$, where α, β are arbitrary.

Q.119 Let $\int_0^1 \int_1^2 \frac{1}{x^2 + y^2} dx dy + \int_1^2 \int_y^2 \frac{1}{x^2 + y^2} dx dy = \iint_R \frac{1}{x^2 + y^2} dy dx$ Recognise the region

R of integration on the r.h.s. and then evaluate the integral on the right in the order indicated. (7)

Ans:

$$I_1 = \int_0^1 \int_1^2 \frac{1}{x^2 + y^2} dx dy$$

$$I_2 = \int_1^2 \int_y^2 \frac{1}{x^2 + y^2} dx dy$$

For I_1 , region of integration is bonded by the lines $x = 1, x = 2, y=0, y = 1$ i.e. region R_1 in figure. For I_2 , region of integration is bonded by the lines $x = y, x = 2, y = 1, y = 2$ i.e. region R_2 in figure.

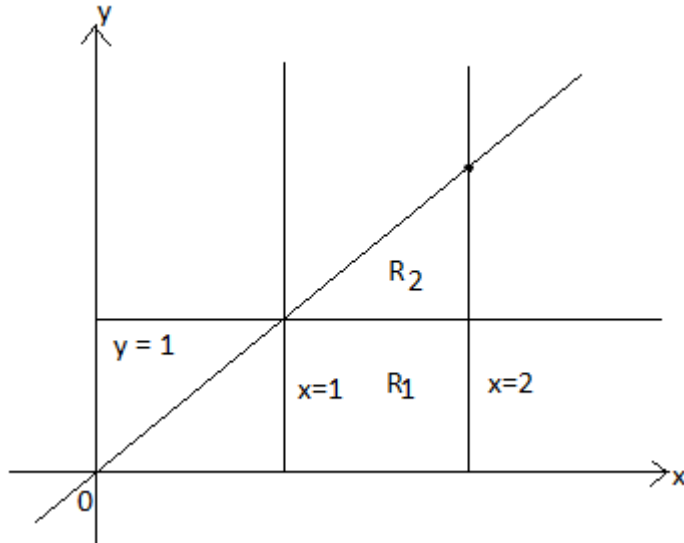

Now the region R of integration i.e. union of R_1 and R_2 is bonded by the lines $y = 0, y = x, x = 1, x = 2$

$$\begin{aligned} \iint_R \frac{1}{x^2 + y^2} dx dy &= \int_{x=1}^2 \int_{y=0}^x \frac{1}{x^2 + y^2} dy dx = \int_1^2 \left[\frac{1}{y} \tan^{-1} \frac{y}{x} \right]_0^x dx \\ &= \int_1^2 \frac{1}{x} \tan^{-1} 1 dx = \int_1^2 \frac{1}{x} \frac{\pi}{4} dx = \frac{\pi}{4} (\log x)_1^2 = \frac{\pi}{4} \log 2. \end{aligned}$$

Q.120 Compute the volume of the solid bounded by the surfaces $z = \sqrt{4 - x^2 - y^2}$ and $z = \frac{1}{3}(x^2 + y^2)$. (7)

Ans:

Let V be the volume of solid. The two surfaces intersect at $z = 1$. Therefore

$$\begin{aligned} V &= \int_{x=-\sqrt{3}}^{\sqrt{3}} \int_{y=-\sqrt{3-x^2}}^{\sqrt{3-x^2}} \int_{z=\frac{1}{3}(x^2+y^2)}^{\sqrt{4-x^2-y^2}} dz dy dx \\ &= \int_{-\sqrt{3}}^{\sqrt{3}} \int_{-\sqrt{3-x^2}}^{\sqrt{3-x^2}} (\sqrt{4-x^2-y^2} - \frac{1}{3}(x^2+y^2)) dy dx \end{aligned}$$

Let $x = r \cos \theta$, $y = r \sin \theta$. Then $dydx = r dr d\theta$, r varies from 0 to $\sqrt{3}$ and θ varies from 0 to 2π . Then

$$V = \int_0^{2\pi} \int_0^{\sqrt{3}} \left(\sqrt{4-r^2} - \frac{r^2}{3} \right) r dr d\theta = \frac{19}{6} \pi$$

Q.121 Let $\mu(x, y)$ be an integrating factor for differential equation $Mdx + Ndy = 0$ and $\Psi(x, y) = 0$ is a solution of this equation, then show that $\mu G(\Psi)$ is also an integrating factor of this equation, G being a non-zero differentiable function of Ψ . (6)

Ans:

Since μ be an integrating factor for differential equation $Mdx + Ndy = 0$. Thus $\mu(Mdx + Ndy) = 0$ is an exact differential equation.

Also $d\phi = \mu (Mdx + Ndy)$ (given)

Because, $\phi = \text{constant}$, is a solution.

Let $G(\phi)$ be any function of ϕ

Therefore $G(\phi)d\phi = \mu G(\phi) (Mdx + Ndy)$.

Let $\int G(\phi) d\phi = F(\phi)$, then $dF(\phi) = G(\phi) d\phi$

Since terms on left is an exact differential, the terms on right must be an exact differential.

Therefore, $\mu G(\phi)$ is an integrating factor of differential equation.

Q.122 Solve the initial value problem $\frac{dy}{dx} = y^2 \left(\ln(x) + \frac{1}{x} \right) + y$, $y(0) = 1$. (8)

Ans:

$$\frac{dy}{dx} = y^2 \left(\ln x + \frac{1}{x} \right) + y$$

$$\frac{1}{y^2} \frac{dy}{dx} - \frac{1}{y} = \ln x + \frac{1}{x}$$

$$\text{Let } \frac{-1}{y} = t \quad \Rightarrow \quad \frac{1}{y^2} \frac{dy}{dx} = \frac{dt}{dx}$$

Therefore, $\frac{dt}{dx} + t = \ln x + \frac{1}{x}$ is the differential equation.

I.F. = $e^{\int dx} = e^x$. Hence solution is

$$t.e^x = \int e^x \left(\ln x + \frac{1}{x} \right) dx + c = e^x \ln x + c$$

$$\Rightarrow \frac{-1}{y} e^x = e^x \ln x + c \Rightarrow e^x (y \ln x + 1) + cy = 0$$

Q.123 Find general solution of differential equation $y''' + y' = \sec x$. (7)

Ans:

$$y'' + y' = \sec x$$

can be written as $(D^2 + D) y = \sec x$

i.e. $D(D + 1) y = \sec x$

Therefore, auxiliary equation is $m^2 + m = 0$

$$m = 0, -1$$

$$\text{C.F.} = C_1 + C_2 e^{-x}$$

$$\text{P.I.} = \frac{1}{D(D+1)} \sec x = \left(\frac{1}{D} - \frac{1}{D+1} \right) \sec x$$

$$= \frac{1}{D} \sec x - e^{-x} \int e^x \sec x dx \quad \left\{ \frac{1}{D-\alpha} X = e^{\alpha x} \int e^{-\alpha x} X dx \right\}$$

$$= \ln(\sec x + \tan x) - e^{-x} \left[\frac{e^x}{2} (\sec x - \sec x \tan x) \right]$$

$$= \ln(\sec x + \tan x) - \frac{\sec x}{2} (1 - \tan x)$$

$$\text{Therefore, } y = C_1 + C_2 e^{-x} + \ln(\sec x + \tan x) + \frac{\sec x}{2} (\tan x - 1)$$

Q.124 Solve the boundary value problem

$$x^3 y'' - x^2 y' + xy = 1, \quad y(1) = \frac{1}{4}, \quad y(e) = e + \frac{1}{4e}. \quad (7)$$

Ans:

The given differential equation is $x^2 y'' - xy' + y = \frac{1}{x}$

$$\text{i.e. } (\theta(\theta-1) - \theta + 1) y = \frac{1}{x}, \quad \theta = \frac{d}{dt}, \quad x = e^t, \quad \theta^2 - 2\theta + 1 = 0 \Rightarrow \theta = 1, 1$$

$$\text{C.F.} = x (C_1 + C_2 \log x)$$

$$\begin{aligned}
 \text{P.I.} &= \frac{1}{(\theta-1)^2} \cdot \frac{1}{x} \\
 &= \frac{1}{(\theta-1)} \left[x \int \frac{1}{x} \cdot \frac{1}{x^2} dx \right] \quad \left\{ \frac{1}{\theta-\alpha} X = x^\alpha \int \frac{x}{x^{\alpha+1}} dx \right\} \\
 &= \frac{1}{(\theta-1)} \left(-\frac{1}{2x} \right) = \frac{-1}{2} \cdot \left(\frac{-1}{2} \right) \cdot \frac{1}{x} = \frac{1}{4x}
 \end{aligned}$$

Therefore, $y = x (C_1 + C_2 \log x) + \frac{1}{4} \cdot \frac{1}{x}$

$$y(1) = \frac{1}{4} \Rightarrow \frac{1}{4} = C_1 + \frac{1}{4} \Rightarrow C_1 = 0$$

$$y(e) = e + \frac{1}{4e} \Rightarrow e + \frac{1}{4e} = eC_2 + \frac{1}{4e} \Rightarrow C_2 = 1$$

$$y = x \log x + \frac{1}{4x}$$

Q.125 Solve the differential equation $y^{iv} + 32y'' + 256y = 0$. (5)

Ans:

$$y^{iv} + 32y'' + 256y = 0$$

i.e. $(D^4 + 32D^2 + 256) y = 0$

A.E. is $m^4 + 32m^2 + 256 = 0$

i.e. $(m^2 + 16)^2 = 0$

$$\Rightarrow m = \pm 4i, \pm 4i$$

Therefore, $y = (C_1 + C_2 x) (C_3 \cos 4x + C_4 \sin 4x)$

Q.126 Using power series method find a fifth degree polynomial approximation to the solution of initial value problem

$$(x-1)y'' + xy' + y = 0, \quad y(0) = 2, \quad y'(0) = -1. \quad (9)$$

Ans:

Let $x = 0$ be an ordinary point

Let $y = \sum_{n=0}^{\infty} a_n x^n, \quad a_0 \neq 0$ be solution about $x = 0$

$$y' = \sum_{n=1}^{\infty} n a_n x^{n-1}$$

$$y'' = \sum_{n=2}^{\infty} n(n-1) a_n x^{n-2}$$

Then given differential equation becomes

$$\begin{aligned}
 &(x-1) \sum_{n=2}^{\infty} n(n-1)a_n x^{n-2} + x \sum_{n=1}^{\infty} n a_n x^{n-1} + \sum_{n=0}^{\infty} a_n x^n = 0 \\
 \Rightarrow &\sum_{n=2}^{\infty} n(n-1)a_n x^{n-1} - \sum_{n=2}^{\infty} n(n-1)a_n x^{n-2} + \sum_{n=1}^{\infty} n a_n x^n + \sum_{n=0}^{\infty} a_n x^n = 0 \\
 \Rightarrow &(a_0 - 2a_2) + \sum_{n=1}^{\infty} [(n+1)(na_{n+1} + a_n - (n+2)a_{n+2})] x^n = 0
 \end{aligned}$$

equating coefficient of x^n to zero, we get

$$a_2 = \frac{a_0}{2}, \quad (n+2)a_{n+2} = na_{n+1} + a_n,$$

Also $y(0) = 2 \Rightarrow a_0 = 2$

$y'(0) = -1 \Rightarrow a_1 = -1$

Therefore, $a_0 = 2, a_1 = -1, a_2 = 1, a_3 = 0, a_4 = 1/4, a_5 = 3/20, \dots$

$$y = 2 - x + x^2 + \frac{x^4}{4} + \frac{3x^5}{20} + \dots$$

Q.127 Let $J_\nu(x)$ denote the Bessel's function of first kind. Find the generating function of the sequence $\{J_\nu(x), \nu = 0, \pm 1, \pm 2, \dots\}$. Hence prove that

$$\begin{aligned}
 \cos x &= J_0(x) - 2J_2(x) + 2J_4(x) - \dots \dots \dots \\
 \sin x &= 2J_1(x) - 2J_3(x) + 2J_5(x) - \dots \dots \dots
 \end{aligned} \tag{7}$$

Ans:

$J_n(x)$ is the coefficient of z^n in expansion of $e^{\frac{x}{2}\left(\frac{z-1}{z}\right)}$.

$$e^{\frac{x}{2}\left(\frac{z-1}{z}\right)} = \left(1 + \frac{x}{2}z + \frac{x^2}{4} \frac{z^2}{2} + \dots\right) \left(1 - \frac{x}{2}z^{-1} + \frac{x^2}{4} \frac{z^{-2}}{2} + \dots\right)$$

Coefficient of $z^n, n \geq 0$

$$\begin{aligned}
 &= \frac{\left(\frac{x}{2}\right)^n}{|n|} + \frac{\left(\frac{x}{2}\right)^{n+1}}{|n+1|} \cdot \left(\frac{-x}{2}\right) + \frac{\left(\frac{x}{2}\right)^{n+2}}{|n+2|} \cdot \frac{\left(\frac{-x}{2}\right)^2}{2} + \dots \\
 &= \sum_{m=0}^{\infty} \frac{(-1)^m}{|m|n+m} \left(\frac{x}{2}\right)^{n+2m} = J_n(x)
 \end{aligned}$$

Similarly we can get the result for $n < 0$. Set $z = i$. Then

$$e^{\frac{x}{2}\left(z-\frac{1}{z}\right)} = e^{ix} = \cos x + i \sin x. \text{ Thus } \cos x + i \sin x = \sum_{n=-\infty}^{\infty} J_n(x)(i)^n$$

Comparing real and imaginary parts and by using $J_{-n}(x) = (-1)^n J_n(x)$ we get

$$\cos(x) = J_0(x) - 2 J_2(x) + 2 J_4(x) + \dots$$

$$\sin(x) = 2[J_1(x) + J_3(x) + J_5(x) + \dots]$$

Q.128 Show that for Legendre polynomials $P_n(x)$

$$\int_{-1}^1 x P_n(x) P_{n-1}(x) dx = \frac{2n}{4n^2 - 1}, n = 1, 2, \dots \tag{7}$$

Ans:

$$\int_{-1}^1 x P_n(x) P_{n-1}(x) dx$$

We know that $(2n-1) x P_{n-1} = n P_n + (n-1) P_{n-2}$

Multiplying by $P_n(x)$ both sides and integrating, we get

$$\begin{aligned} (2n-1) \int_{-1}^1 x P_n(x) P_{n-1}(x) dx &= \int_{-1}^1 n P_n^2(x) dx + (n-1) \int_{-1}^1 P_{n-2}(x) P_n(x) dx \\ &= n \int_{-1}^1 P_n^2(x) dx \\ &= n \cdot \frac{2}{2n+1} \left\{ \int_{-1}^1 P_m(x) P_n(x) dx = \begin{cases} 0, & m \neq n \\ \frac{2}{2n+1}, & m = n \end{cases} \right\} \end{aligned}$$

$$\text{Therefore, } \int_{-1}^1 x P_n(x) P_{n-1}(x) dx = \frac{2n}{4n^2 - 1}$$

Q.129 For the function $f(x, y) = \begin{cases} \frac{xy(2x^2 - 3y^2)}{x^2 + y^2}, & (x, y) \neq (0, 0) \\ 0, & (x, y) = (0, 0) \end{cases}$ show that

$$f_{xy}(0, 0) \neq f_{yx}(0, 0).$$

(8)

Ans:

For obtaining f_{xy} and f_{yx} we need f_x and f_y . For obtaining these derivatives we use the definition of f_x and f_y

$$f_x = \lim_{\delta x \rightarrow 0} \frac{f(x + \delta x, y) - f(x, y)}{\delta x}, \quad f_y = \lim_{\delta y \rightarrow 0} \frac{f(x, y + \delta y) - f(x, y)}{\delta y}$$

Thus

$$f_x(0,0) = \lim_{\Delta x \rightarrow 0} \frac{f(\Delta x, 0) - f(0,0)}{\Delta x} = 0, \quad f_y(0,0) = \lim_{\Delta y \rightarrow 0} \frac{f(0, \Delta y) - f(0,0)}{\Delta y} = 0,$$

$$f_x(0, y) = \lim_{\Delta x \rightarrow 0} \frac{f(\Delta x, y) - f(0, y)}{\Delta x} = \lim_{\Delta x \rightarrow 0} \frac{y[2(\Delta x)^2 - 3y^2]\Delta x}{[(\Delta x)^2 + y^2]\Delta x} = -3y$$

$$f_y(x, 0) = \lim_{\Delta y \rightarrow 0} \frac{f(x, \Delta y) - f(x, 0)}{\Delta y} = \lim_{\Delta y \rightarrow 0} \frac{x[2x^2 - 3(\Delta y)^2]\Delta y}{[(x)^2 + (\Delta y)^2]\Delta y} = 2x.$$

$$f_{xy}(0,0) = \frac{\partial}{\partial x} \left(\frac{\partial f}{\partial y} \right)_{(0,0)} = \lim_{\Delta x \rightarrow 0} \frac{f_y(\Delta x, 0) - f_y(0,0)}{\Delta x} = \lim_{\Delta x \rightarrow 0} \frac{2\Delta x}{\Delta x} = 2,$$

$$f_{yx}(0,0) = \frac{\partial}{\partial y} \left(\frac{\partial f}{\partial x} \right)_{(0,0)} = \lim_{\Delta y \rightarrow 0} \frac{f_x(0, \Delta y) - f_x(0,0)}{\Delta y} = \lim_{\Delta y \rightarrow 0} \frac{-3\Delta y}{\Delta y} = -3.$$

Hence $f_{xy}(0,0) \neq f_{yx}(0,0)$.

Q.130 Find the absolute maximum and minimum values of the function

$f(x, y) = 4x^2 + 9y^2 - 8x - 12y + 4$ over the rectangle in the first quadrant bounded by the lines $x = 2, y = 3$ and the coordinate axes.

(8)

Ans

The function f can attain maximum/ minimum values at the critical points or on the boundary of the rectangle OABC, such that O (0,0), A(2,0), B(2,3), C (0,3). We have $f_x = 8x - 8 = 0, f_y = 18y - 12 = 0$. The critical point is $(x,y)=(1,2/3)$. Now, since $rt - s^2 > 0$ and $r > 0$. The point $(1,2/3)$ is a point of relative minimum. The minimum value is $f(1,2/3)=-4$. On the boundary line OA, we have $y = 0$ and $f(x,y) = f(x,0) = g(x) = 4x^2 - 8x + 4$, which is a

function of one variable. Setting $\frac{dg}{dx} = 0$, we get $x = 1$. Now, $\frac{d^2g}{dx^2} = 8 > 0$. Therefore, at $x = 1$,

the function has a minimum. The minimum value is $g(1)=0$. Also, at the corners $(0,0), (2,0)$ we have $f(0,0)=g(0) = 4, f(2,0)=4$. On the boundary line AB, we have $x = 2$ and $f(x,y) = h(y) = 9y^2 - 12y + 4$, which is a function of one variable. Setting $\frac{dh}{dy} = 0$, we get $y = 2/3$. Now,

$\frac{d^2h}{dy^2} = 18 > 0$. Therefore, at $y=2/3$, the function has a minimum. The minimum value is $f(2,2/3)=0$. Also, at the corners $(2,3)$ we have $f(2,3)=49$. On the boundary line BC, we have $y =$

3 and $f(x,y) = g(x) = 4x^2 - 8x + 49$, which is a function of one variable. Setting $\frac{dg}{dx} = 0$, we get

$x = 1$. Now, $\frac{d^2g}{dx^2} = 8 > 0$. Therefore, at $x=1$, the function has a minimum. The minimum value

is $f(1,3)=45$. Also, at the corners $(0,3)$ we have $f(0,3)=49$. On the boundary line CO, we have $x = 0$ and $f(x,y) = h(y) = 9y^2 - 12y + 4$, which is the same case as for $x=2$. Therefore, the absolute minimum value is -4 at $(1,2/3)$ and the absolute maximum value is 49 at $(2,3)$ and $(0,3)$.

Q.131 If $f(x, y) = \tan^{-1}(xy)$, find an approximate value of $f(1.1,0.8)$ using the Taylor's series quadratic approximation. (8)

Ans:

Using the Taylor series quadratic approximation, one can write

$$f(x + h, y + k) = f(x, y) + (hf_x + kf_y) + \frac{1}{2!}(h^2 f_{xx} + 2hkf_{xy} + k^2 f_{yy}) \text{ ----- (1)}$$

Here $h=0.1, k= -0.2$ Thus

$$f(1.1,0.8) = f(1,1) + (0.1f_x - 0.2f_y)_{1,1} + \frac{1}{2!}((0.1)^2 f_{xx} + 2(0.1)(-0.2)f_{xy} + (-0.2)^2 f_{yy})_{1,1} \text{ ----- (2)}$$

Now $f(1,1) = \tan^{-1}(xy)_{1,1} = \tan^{-1}1 = \frac{\pi}{4} = \frac{22}{7} \frac{1}{4} = \frac{11}{14} = 0.7857$

$$(f_x)_{1,1} = \left(\frac{y}{1+x^2y^2} \right)_{1,1} = \frac{1}{2}, (f_y)_{1,1} = \left(\frac{x}{1+x^2y^2} \right)_{1,1} = \frac{1}{2}. \text{ Thus } (hf_x + kf_y) = \frac{0.1}{2} - \frac{0.2}{2}$$

$$= -(0.05); (f_{xx})_{1,1} = - \left[\frac{2xy^2}{(1+x^2y^2)^2} \right]_{1,1} = -\frac{1}{2}; f_{yy}(1,1) = \left(\frac{-2yx^2}{(1+x^2y^2)^2} \right)_{1,1} = -\frac{1}{2}$$

$$f_{xy}(1,1) = \left[\frac{1-x^2y^2}{(1+x^2y^2)^2} \right]_{1,1} = 0. \text{ On using the values of } f(1,1), f_x(1,1),$$

$f_y(1,1), f_{xx}(1,1), f_{yy}(1,1), f_{xy}(1,1)$ in Eqn (2), we get

$$f(1.1,0.8) = 0.7857 - (0.05) + \frac{1}{2} \left((0.1)^2 \left(-\frac{1}{2} \right) + 0 + (-0.2)^2 \left(-\frac{1}{2} \right) \right) \approx 0.7207$$

Q.132 Evaluate the integral $\iint_R \sqrt{x^2 + y^2} dx dy$ by changing to polar coordinates, where R is the region in the x-y plane bounded by the circles $x^2 + y^2 = 4$ and $x^2 + y^2 = 9$. (8)

Ans:

Using $x = r \cos\theta, y = r \sin\theta$, we get $dx dy = r dr d\theta$, and

$$I = \int_0^{2\pi} \int_2^3 r(rdrd\theta) = \int_0^{2\pi} \left[\frac{r^3}{3} \right]_2^3 d\theta = \frac{19}{3} \int_0^{2\pi} d\theta = \frac{38}{3} \pi$$

Q.133 Find the solution of the differential equation $(y-x+1)dy - (y+x+2) dx = 0$. (6)

Ans:

When written in the form $\frac{dy}{dx} = \frac{y+x+2}{y-x+1}$; the differential equation (d.e.) belongs to the category of reducible homogeneous d.e. of first order and can be integrated by reducing to the homogeneous form. Before we indulge into this let us first examine the given differential equation by writing it in the form $M(x, y)dx + N(x, y)dy = 0$

Here $M = -(y + x + 2)$; $N = y - x + 1$

$$\therefore \frac{\partial M}{\partial y} = -1; \quad \frac{\partial N}{\partial x} = -1, \text{ Since } \frac{\partial M}{\partial y} = \frac{\partial N}{\partial x}$$

Therefore the given equation is exact, consequently, we write it as follows

$$ydy - xdy + dy - ydx - xdx - 2dx = 0$$

$$\text{or } ydy + dy - (xdy + ydx) - xdx - 2dx = 0$$

$$\text{Integrating } \frac{y^2}{2} + y - xy - \frac{x^2}{2} - 2x = C$$

In fact, on observation for its exactness should have been made before classifying it to any other category. If one fails to make this observation then it can be reduced to homogenous form y making the transformation $x = X + h, y = Y + k$ which yields

$$\frac{dY}{dX} = \frac{Y + X + h + k + 2}{Y - X + k - h + 1}$$

Choose h, k such that $h + k + 2 = 0, k - h + 1 = 0$. Thus, we get $h = -\frac{1}{2}, k = -\frac{3}{2}$ and the d.e.

$$\text{reduces to } \frac{dY}{dX} = \frac{Y + X}{Y - X} \rightarrow YdY - XdY - YdX - XdX = 0$$

$$\text{Integrating } \frac{Y^2}{2} - XY - \frac{X^2}{2} = C; X = x + \frac{1}{2}, Y = y + \frac{3}{2}.$$

Q.134 Solve the differential equation $\cot 3x \frac{dy}{dx} - 3y = \cos 3x + \sin 3x, 0 < x < \pi/2$. (6)

Ans:

On dividing throughout by $\cot 3x$, the given differential equation can be written as

$$\frac{dy}{dx} - 3(\tan 3x)y = (\tan 3x)(\cos 3x + \sin 3x) = \sin 3x + \frac{\sin^2 3x}{\cos 3x} \quad \text{----- (1)}$$

Eqn(2) is a linear differential equation of the form

$$\frac{dy}{dx} + P(x)y = Q(x); \text{ where } P(x) = -3 \tan 3x; Q(x) = \sin 3x + \frac{\sin^2 3x}{\cos 3x}$$

$$\text{I.F. } e^{\int P dx} = e^{-3 \int \tan 3x dx} = e^{\log \cos 3x} = \cos 3x .$$

Multiplying (1) throughout by $\cos 3x$ and integrating, we get

$$\begin{aligned} y \cos 3x &= \int \sin 3x \cos 3x dx + \int \sin^2 3x dx + C \\ &= \frac{1}{2} \int \sin 6x dx + \frac{1}{2} \int (1 - \cos 6x) dx + C = -\frac{1}{12} \cos 6x + \frac{x}{2} - \frac{1}{12} \sin 6x + C . \end{aligned}$$

Q.135 Show that the functions $1, \sin x, \cos x$ are linearly independent. (4)

Ans:

For functions 1, sin x, cos x to be linearly independent the Wronskian of the functions given by

$$W(x) = \begin{vmatrix} f(x) & g(x) & h(x) \\ f'(x) & g'(x) & h'(x) \\ f''(x) & g''(x) & h''(x) \end{vmatrix} = \begin{vmatrix} 1 & \sin x & \cos x \\ 0 & \cos x & -\sin x \\ 0 & -\sin x & -\cos x \end{vmatrix} = -1$$

has to be non-zero. Here it is (-1) ≠ 0. Hence the result.

Q.136 Using method of undetermined coefficients, find the general solution of the equation $y'' - 4y' + 13y = 12e^{2x} \sin 3x$. (8)

Ans:

For obtaining the general solution of

$$y'' - 4y' + 13y = 12e^{2x} \sin 3x \quad \text{----- (1)}$$

We have to determine y_e , the complementary function that is the solution of (1) without the RHS and the P.I. Here for determining the P.I. we have to use the method of undetermined coefficients. For y_c we have to write the auxiliary/characteristic equation which is $m^2 - 4m + 13 = 0$. The roots of the equation are $m = 2 + 3i, 2 - 3i$. The complementary function is $y_c(x) = e^{2x}(A \cos 3x + B \sin 3x)$. We note that $e^{2x} \sin 3x$ appears both in the complementary function and the right hand side $r(x)$. Therefore, we choose $y_p(x) = xe^{2x}(C_1 \cos 3x + C_2 \sin 3x)$.

Consequently we have

$$y'_p(x) = (1 + 2x)e^{2x}(C_1 \cos 3x + C_2 \sin 3x) + 3xe^{2x}(C_2 \cos 3x - C_1 \sin 3x),$$

$$y''_p(x) = (4 + 4x)e^{2x}(C_1 \cos 3x + C_2 \sin 3x) + 9xe^{2x}(-C_1 \cos 3x - C_2 \sin 3x) + 6(1 + 2x)e^{2x}(C_2 \cos 3x - C_1 \sin 3x)$$

Substituting in the given equations, we get

$$y''_p - 4y'_p + 13y_p = e^{2x} \cos 3x(C_1(4 + 4x) + 6C_2(1 + 2x) - 9C_1x - 4C_1(1 + 2x) - 12xC_2 + 13xC_1) + e^{2x} \sin 3x(C_2(4 + 4x) - 6C_1(1 + 2x) - 9C_2x - 4C_2(1 + 2x) + 12xC_1 + 13xC_2) = 12e^{2x} \sin 3x$$

$$\Rightarrow 6C_2e^{2x} \cos 3x - 6C_1e^{2x} \sin 3x = 12e^{2x} \sin 3x$$

Comparing, both sides we get $C_1 = -2, C_2 = 0$. Therefore, the particular integral is $y_p = -2xe^{2x} \cos 3x$. The general solution is $y(x) = e^{2x}(A \cos 3x + B \sin 3x - 2x \cos 3x)$.

Q.137 Solve $x^2 \frac{d^2 y}{dx^2} - 3x \frac{dy}{dx} + y = \log x \frac{\sin(\log x) + 1}{x}$. (8)

Ans:

The given differential equation has to be transformed to the differential equation with constant coefficients by changing the independent variable x to t using the transformation

$$x = e^t \quad \text{or } t = \log x. \text{ Thus, } x \frac{dy}{dx} = \frac{dy}{dt} = Dy, \quad x^2 \frac{d^2 y}{dx^2} = D(D-1)y$$

The given d.e. assumes the following form:

$$(D(D-1)-3D+1)y = (D^2 - 4D+1)y = e^{-t}t(1 + \sin t) \quad \text{----- (1)}$$

Characteristic equation of (1) is $m^2 - 4m + 1 = 0$ ----- (2)

Roots of (2) are $m = 2 \pm \sqrt{3}$.

Thus, C.F. = $c_1 e^{(2+\sqrt{3})t} + c_2 e^{(2-\sqrt{3})t}$

$$\text{P.I.} = \frac{1}{D^2 - 4D + 1} e^{-t}t(1 + \sin t) = e^{-t} \frac{1}{(D-1)^2 - 4(D-1) + 1} t(1 + \sin t)$$

$$= e^{-t} \left\{ \frac{1}{D^2 - 6D + 6} t + \frac{1}{D^2 - 6D + 6} t \sin t \right\}$$

$$\frac{1}{D^2 - 6D + 6} t = \frac{1}{6} \left(1 - \frac{6D - D^2}{6} \right)^{-1} t = \frac{1}{6} (1 + D)t = \frac{1}{6} (1 + t)$$

$$\frac{1}{D^2 - 6D + 6} t \sin t = \text{I.P. of } \frac{1}{D^2 - 6D + 6} t e^{it} = \text{I.P. of } e^{it} \frac{1}{(D+i)^2 - 6(D+i) + 6} t$$

$$= \text{I.P. of } \frac{e^{it}}{5-6i} \left(1 + \frac{(2i-6)D + D^2}{5-6i} \right)^{-1} t = \text{I.P. of } \frac{5+6i}{61} (\cos t + i \sin t) \left(t - \frac{(2i-6)}{5-6i} \right)$$

$$= \frac{1}{61} (5 \sin t + \cos t) + \frac{2}{3721} (27 \sin t + 191 \cos t).$$

$$y = c_1 e^{(2+\sqrt{3})t} + c_2 e^{(2-\sqrt{3})t} + e^{-t} \left[\frac{1}{6} (1+t) + \frac{1}{61} (5 \sin t + \cos t) + \frac{2}{3721} (27 \sin t + 191 \cos t) \right]$$

Q.138 In an L-C-R circuit, the charge q on a plate of a condenser is given by

$L \frac{d^2 q}{dt^2} + R \frac{dq}{dt} + \frac{q}{C} = E \sin pt$. The circuit is tuned to resonance so that $p^2 = 1/LC$. If initially the current I and the charge q be zero, show that, for small values of R/L , the current in the circuit at time t is given by $(Et/2L) \sin pt$. (8)

Ans:

Given differential equation is $(Lm^2 + Rm + 1/C)q = E \sin pt$. It's A.E. is $(Lm^2 + Rm + 1/C) = 0$

which gives $m = -\frac{R}{2L} \pm \sqrt{\left(\frac{R^2}{4L^2} - \frac{1}{LC}\right)}$. As R/L is small, $\frac{R^2}{4L^2} \approx 0$ therefore, to the first order

in R/L , $m = -\frac{R}{2L} \pm i \frac{1}{\sqrt{LC}} = -\frac{R}{2L} \pm ip$, where $p^2 = \frac{1}{LC}$. Thus,

C.F. = $e^{-\frac{Rt}{2L}} (c_1 \cos pt + c_2 \sin pt) = (1 - Rt/2L)(c_1 \cos pt + c_2 \sin pt)$, rejecting terms in $(R/L)^2$ etc.

Thus P.I. = $\frac{1}{Lm^2 + Rm + 1/C} E \sin pt = -\frac{E}{Rp} \cos pt$.

Thus the complete solution is $q = (1 - Rt/2L)(c_1 \cos pt + c_2 \sin pt) - \frac{E}{Rp} \cos pt$.

$$\therefore i = \frac{dq}{dt} = (1 - Rt/2L)(-c_1 \sin pt + c_2 \cos pt) p - \frac{R}{2L}(c_1 \cos pt + c_2 \sin pt) + \frac{E}{R} \sin pt$$

Initially when t=0, q=0, i=0, we get $c_1 = E/Rp$, $c_2 = E/2Lp^2$. Thus, substituting these values of constants, we get

$$i = (1 - Rt/2L) \left(-\frac{E}{Rp} \sin pt + \frac{E}{2Lp^2} \cos pt \right) p - \frac{R}{2L} \left(\frac{E}{Rp} \cos pt + \frac{E}{2Lp^2} \sin pt \right) + \frac{E}{R} \sin pt = \frac{Et}{2L} \sin pt$$

Q.139 Find a linear transformation T from \mathbb{R}^3 into \mathbb{R}^3 such that (8)

$$T \begin{pmatrix} 1 \\ 1 \\ 1 \end{pmatrix} = \begin{pmatrix} 6 \\ 2 \\ 4 \end{pmatrix}, T \begin{pmatrix} 1 \\ -1 \\ 1 \end{pmatrix} = \begin{pmatrix} 2 \\ -4 \\ 2 \end{pmatrix}, T \begin{pmatrix} 1 \\ -2 \\ 3 \end{pmatrix} = \begin{pmatrix} 6 \\ 6 \\ 5 \end{pmatrix}.$$

Ans:

Let the matrix $A = \begin{pmatrix} a_1 & a_2 & a_3 \\ b_1 & b_2 & b_3 \\ c_1 & c_2 & c_3 \end{pmatrix}$. Thus $A \begin{pmatrix} 1 \\ 1 \\ 1 \end{pmatrix} = \begin{pmatrix} 6 \\ 2 \\ 4 \end{pmatrix}$,

$$\begin{pmatrix} a_1 & a_2 & a_3 \\ b_1 & b_2 & b_3 \\ c_1 & c_2 & c_3 \end{pmatrix} \begin{pmatrix} 1 \\ -1 \\ 1 \end{pmatrix} = \begin{pmatrix} 2 \\ -4 \\ 2 \end{pmatrix}, \begin{pmatrix} a_1 & a_2 & a_3 \\ b_1 & b_2 & b_3 \\ c_1 & c_2 & c_3 \end{pmatrix} \begin{pmatrix} 1 \\ -2 \\ 3 \end{pmatrix} = \begin{pmatrix} 6 \\ 6 \\ 5 \end{pmatrix}. \text{ Solving, } A = \begin{pmatrix} 1 & 2 & 3 \\ -15/2 & 3 & 13/2 \\ 1 & 1 & 2 \end{pmatrix}.$$

Q.140 Examine, whether the matrix A is diagonalizable. $A = \begin{pmatrix} -2 & 2 & -3 \\ 2 & 1 & -6 \\ -1 & -2 & 0 \end{pmatrix}$. If, so, obtain the

matrix P such that $P^{-1}AP$ is a diagonal matrix. (8)

Ans:

The characteristic equation of the matrix A is given by

$$|A - \lambda I| = \begin{vmatrix} -2 - \lambda & 2 & -3 \\ 2 & 1 - \lambda & -6 \\ -1 & -2 & -\lambda \end{vmatrix} = 0 \text{ or } \lambda^3 + \lambda^2 - 21\lambda - 45 = 0 \text{ or } \lambda = 5, -3, -3.$$

Eigenvector corresponding to $\lambda = 5$ is the solution of the system

$$(A - 5I)X = \begin{bmatrix} -7 & 2 & -3 \\ 2 & -4 & -6 \\ -1 & -2 & -5 \end{bmatrix} \begin{bmatrix} x \\ y \\ z \end{bmatrix} = \begin{bmatrix} 0 \\ 0 \\ 0 \end{bmatrix}. \text{ The solution of this system is } [1, 2, -1]^T.$$

Eigenvector corresponding to $\lambda = -3$ is the solution of the system

$$(A + 3I)X = \begin{bmatrix} 1 & 2 & -3 \\ 2 & 4 & -6 \\ -1 & -2 & 3 \end{bmatrix} \begin{bmatrix} x \\ y \\ z \end{bmatrix} = \begin{bmatrix} 0 \\ 0 \\ 0 \end{bmatrix} \text{ or } x + y + z = 0. \text{ The rank of the matrix is 1. Therefore,}$$

the system has two linearly independent solutions. Taking $z = 0, y = 1$, we get eigenvector as $[-2, 1, 0]^T$, and taking $y = 0, z = 1$, we get eigenvector as $[3, 0, 1]^T$. Thus the matrix P is given by

$$P = \begin{pmatrix} 1 & -2 & 3 \\ 2 & 1 & 0 \\ -1 & 0 & 1 \end{pmatrix} \text{ and } P^{-1} = \begin{pmatrix} 1 & 2 & -3 \\ -2 & 4 & 6 \\ 1 & 2 & 5 \end{pmatrix} \text{ and } P^{-1}AP = \text{diag}(5, -3, -3).$$

Q.141 Investigate the values of μ and λ so that the equations $2x + 3y + 5z = 9, 7x + 3y - 2z = 8, 2x + 3y + \lambda z = \mu$, has (i) no solutions (ii) a unique solution and (iii) an infinite number of solutions. (8)

Ans.

We have $\begin{bmatrix} 2 & 3 & 5 \\ 7 & 3 & -2 \\ 2 & 3 & \lambda \end{bmatrix} \begin{bmatrix} x \\ y \\ z \end{bmatrix} = \begin{bmatrix} 9 \\ 8 \\ \mu \end{bmatrix}$. The system admits of unique solution if and only if, the

coefficient matrix is of rank 3. Thus $\begin{vmatrix} 2 & 3 & 5 \\ 7 & 3 & -2 \\ 2 & 3 & \lambda \end{vmatrix} = 15(5 - \lambda) \neq 0$. Thus for a unique solution

$\lambda \neq 5$ and μ may have any value. If $\lambda = 5$, the system will have no solution for those values of μ

for which the matrices $A = \begin{bmatrix} 2 & 3 & 5 \\ 7 & 3 & -2 \\ 2 & 3 & 5 \end{bmatrix}$ and $k = \begin{bmatrix} 2 & 3 & 5 & 9 \\ 7 & 3 & -2 & 8 \\ 2 & 3 & 5 & \mu \end{bmatrix}$ are not of the same rank. But A

is of rank 2 and K is not of rank 2 unless $\mu=9$. Thus if $\lambda = 5$ and $\mu \neq 9$, the system will have no solution. If $\lambda = 5$ and $\mu=9$, the system will have an infinite number of solutions.

Q.142 Find the power series solution about the point $x_0 = 2$ of the equation $y'' + (x-1)y' + y = 0$. (11)

Ans:

The power series can be written as $y(x) = \sum_{m=0}^{\infty} c_m(x-2)^m$. Substituting in the given equation,

we get $\sum_{m=2}^{\infty} m(m-1)c_m(x-2)^{m-2} + [(x-2)+1]\sum_{m=1}^{\infty} mc_m(x-2)^{m-1} + \sum_{m=0}^{\infty} c_m(x-2)^m = 0$

$$2c_2 + c_1 + c_0 + \sum_{m=3}^{\infty} m(m-1)c_m(x-2)^{m-2} + \sum_{m=1}^{\infty} (m+1)c_m(x-2)^m + \sum_{m=2}^{\infty} mc_m(x-2)^{m-1} = 0$$

$2c_2 + c_1 + c_0 + \sum_{m=1}^{\infty} [(m+2)(m+1)c_{m+2} + (m+1)c_{m+1} + (m+1)c_m](x-2)^m = 0$. Setting the

coefficients of successive powers of x to zero, we get

$2c_2 + c_1 + c_0 = 0, c_{m+2} = -\frac{(c_{m+1} + c_m)}{(m+2)}, m \geq 1$, where c_0, c_1 are arbitrary constants. We obtain

$c_2 = -\frac{1}{2}(c_1 + c_0), c_3 = -\frac{1}{3}(c_1 + c_2) = -\frac{1}{6}(c_1 - c_0), \dots$. The power series solution is

$$y(x) = c_0 \left[1 - \frac{1}{2}(x-2)^2 + \frac{1}{6}(x-2)^3 - \dots \right] + c_1 \left[(x-2) - \frac{1}{2}(x-2)^2 - \frac{1}{6}(x-2)^3 + \dots \right]$$

Q.143 Express $f(x) = x^4 + 2x^3 - 6x^2 + 5x - 3$ in terms of Legendre Polynomial. (5)

Ans:

As $1 = P_0(x), x = P_1(x), x^2 = \frac{1}{3}(2P_2(x) + 1) = \frac{1}{3}(2P_2(x) + P_0(x))$

$x^3 = \frac{1}{5}(2P_3(x) + 3P_1(x)), x^4 = \frac{1}{35}(8P_4(x) + 20P_2(x) + 7P_0(x))$

$f(x) = \frac{1}{35}(8P_4(x) + 28P_3(x) - 120P_2(x) + 217P_1(x) - 168P_0(x))$

Q.144 Express $J_5(x)$ in terms of $J_0(x)$ and $J_1(x)$. (8)

Ans:

We know $J_n(x) = \frac{x}{2n}(J_{n-1}(x) + J_{n+1}(x)), i.e. J_{n+1}(x) = \frac{2n}{x}J_n(x) - J_{n-1}(x)$

Putting $n=1, 2, 3, 4$ successively, we get $J_2(x) = \frac{2}{x}J_1(x) - J_0(x)$

$J_3(x) = \frac{4}{x}J_2(x) - J_1(x) \quad J_4(x) = \frac{6}{x}J_3(x) - J_2(x) \quad J_5(x) = \frac{8}{x}J_4(x) - J_3(x)$ Substituting the

values, we get $J_3(x) = \left[\frac{384}{x^4} - \frac{72}{x^2} - 1 \right] J_1(x) + \left[\frac{12}{x} - \frac{192}{x^3} \right] J_0(x)$

Q.145 If $f(x) = \begin{cases} 0, & -1 < x \leq 0 \\ x, & 0 < x < 1 \end{cases}$ show that $f(x) = \frac{1}{4}P_0(x) + \frac{1}{2}P_1(x) + \frac{5}{16}P_2(x) - \frac{3}{32}P_4(x) + \dots$. (8)

Ans:

As $f(x) = \sum_{n=0}^{\infty} c_n P_n(x)$. Then c_n is given by

$$c_n = \left(n + \frac{1}{2} \right) \int_{-1}^1 f(x) P_n(x) dx = \left(n + \frac{1}{2} \right) \int_0^1 x P_n(x) dx, \text{ thus } c_0 = \left(\frac{1}{2} \right) \int_{-1}^1 x P_0(x) dx = \frac{1}{4},$$

$$c_1 = \frac{1}{2}, c_2 = \frac{5}{16}, c_3 = 0, c_4 = -\frac{3}{32}, \text{ hence } f(x) = \frac{1}{4}P_0(x) + \frac{1}{2}P_1(x) + \frac{5}{16}P_2(x) - \frac{3}{32}P_4(x) + \dots$$

Q.146 Find the extreme value of the function $f(x,y,z) = 2x + 3y + z$ such that $x^2+y^2=5$ and $x + z = 1$ (8)

Ans.

We have the auxiliary function as

$$F_x = 2 + 2\lambda_1 x + \lambda_2 = 0, F_y = 3 + 2\lambda_1 y = 0; F_z = 1 + \lambda_2 = 0 \quad \text{----- (1,2,3)}$$

Using (3) in (1) we get $x = -1/(2\lambda_1)$ -- (4).

Using (2) we get $y = -\frac{3}{2\lambda_1}$ ----- (5).

Using Equations(4) and (5) in $x^2 + y^2 - 5 = 0$ we get $\lambda_1 = \pm \frac{1}{\sqrt{2}}$. For $\lambda_1 = \frac{1}{\sqrt{2}}$, we arrive at the following point.

For the extremum, $\frac{\partial F}{\partial x} = \frac{\partial F}{\partial y} = \frac{\partial F}{\partial z} = 0$, gives $x = -1/(2\lambda_1)$ and $y = -3/(2\lambda_1)$ substituting in

$(x^2 + y^2 - 5) = 0$, we get $\lambda_1 = \pm \frac{1}{\sqrt{2}}$ For $\lambda_1 = \frac{1}{\sqrt{2}}$, we get the point

$$(x, y, z) = \left(-\frac{\sqrt{2}}{2}, -3\frac{\sqrt{2}}{2}, \frac{2+\sqrt{2}}{2} \right) \text{ and } f(x, y, z) = 1 - 5\sqrt{2} \text{ For } \lambda_1 = -\frac{1}{\sqrt{2}} \text{ we get the point}$$

$$(x, y, z) = \left(\frac{\sqrt{2}}{2}, 3\frac{\sqrt{2}}{2}, \frac{2-\sqrt{2}}{2} \right) \text{ and } f(x, y, z) = 1 + 5\sqrt{2}$$

Q.147 Show that the function $f(x, y) = \begin{cases} (x+y)\sin\left(\frac{1}{x+y}\right), & x+y \neq 0 \\ 0, & x+y = 0 \end{cases}$ is continuous at (0,0) but its partial derivatives of first order does not exist at (0,0). (8)

Ans.

$$\text{As } |f(x, y) - f(0,0)| = \left| (x+y)\sin\left(\frac{1}{x+y}\right) \right| \leq |x+y| \leq |x| + |y| \leq 2\sqrt{(x^2 + y^2)} < \epsilon$$

If we choose $\delta < \frac{\epsilon}{2}$ then $|f(x, y) - 0| < \epsilon$, whenever $0 < \sqrt{(x^2 + y^2)} < \delta$

Therefore $\lim_{(x,y) \rightarrow (0,0)} f(x, y) = 0 = f(0,0)$ Hence the given function is continuous at (0,0). Now at

$$(0,0) f_x(0,0) = \lim_{\Delta x \rightarrow 0} \frac{f(\Delta x, 0) - f(0,0)}{\Delta x} = \lim_{\Delta x \rightarrow 0} \sin\left(\frac{1}{\Delta x}\right) \text{ does not exist. Therefore } f_x \text{ does not exist}$$

at (0,0). Similarly $f_y(0,0) = \lim_{\Delta y \rightarrow 0} \frac{f(0,\Delta y) - f(0,0)}{\Delta y} = \lim_{\Delta y \rightarrow 0} \sin\left(\frac{1}{\Delta y}\right)$ does not exist. Therefore f_y does not exist at (0,0).

Q.148 Evaluate the integral $\iiint_T z dx dy dz$, where T is region bounded by the cone $x^2 \tan^2 \alpha + y^2 \tan^2 \beta = z^2$ and the planes $z=0$ to $z=h$ in the first octant. (8)

Ans.

The required region can be written as $0 \leq z \leq \sqrt{x^2 \tan^2 \alpha + y^2 \tan^2 \beta}$, $0 \leq y \leq \sqrt{h^2 - x^2 \tan^2 \alpha} \cot \beta$, $0 \leq x \leq h \cot \alpha$ thus

$$J = \int_0^{h \cot \alpha} \left[\int_0^{(\sqrt{h^2 - x^2 \tan^2 \alpha}) \cot \beta} \frac{1}{2} (x^2 \tan^2 \alpha + y^2 \tan^2 \beta) dy \right] dx. \text{ Let } x \tan \alpha = h \sin \theta$$

$$J = \frac{\cot \beta}{2} \int_0^{\pi/2} \left[h^2 \sin^2 \theta (h \cos \theta) + \frac{1}{3} h^3 \cos^3 \theta \right] h \cot \alpha \cos \theta d\theta = \frac{h^4 \pi}{16} \cot \alpha \cot \beta$$

Q.149 Show that the approximate change in the angle A of a triangle ABC due to small changes $\delta a, \delta b, \delta c$ in the sides a, b, c respectively, is given by $\delta A = \frac{a}{2\Delta} (\delta a - \delta b \cos C - \delta c \cos B)$ where Δ is the area of the triangle. Verify that $\delta A + \delta B + \delta C = 0$ (8)

Ans.

For any triangle ABC, we have under usual notations

$$2 \cos A = \frac{b^2 + c^2 - a^2}{bc}, \quad 2 \cos B = \frac{a^2 + c^2 - b^2}{ac}, \quad 2 \cos C = \frac{a^2 + b^2 - c^2}{ab}$$

Differentiating the first of the above, we get

$$\begin{aligned} -2 \sin A \delta A &= \frac{bc\{2b\delta b + 2c\delta c - 2a\delta a\} - (b^2 + c^2 - a^2)\{b\delta c + c\delta b\}}{b^2 c^2} \\ &= \frac{\delta b\{2b^2 c - b^2 c - c^3 + a^2 c\} + \{2bc^2 - b^2 - c^2 b + a^2 b\}\delta c - 2abc \delta a}{b^2 c^2} \\ &= \frac{[(b^2 c - c^3 + a^2 c)\delta b + (bc^2 - b^2 + a^2 b)\delta c - 2abc \delta a]}{b^2 c^2} \\ &= \frac{2a}{bc} \left[\frac{b^2 - c^2 + a^2}{2ab} \right] \delta b + \frac{2a}{bc} \left[\frac{a^2 + c^2 - b^2}{2bc} \right] \delta c - (\delta a) \frac{2a}{bc} \\ &= \frac{2a}{bc} [\cos C \delta b + \cos B \delta c - \delta a] \end{aligned}$$

Or $\delta A = \frac{a}{bc \sin A} [\delta a - \cos C \delta b - \cos B \delta c]$

$$\delta A = \frac{a}{2\Delta} [\delta a - \delta b \cos C - \delta c \cos B] \quad (\because 2\Delta = bc \sin A) \quad \text{QED (Ist part)}$$

$$\delta B = \frac{b}{2\Delta} [\delta b - \delta c \cos A - \delta a \cos C]$$

$$\delta C = \frac{c}{2\Delta} [\delta c - \delta a \cos B - \delta b \cos A]$$

Adding the above three expressions for $\delta A, \delta B, \delta C$ we get

$$\delta A + \delta B + \delta C = 0$$

Q.150 If $x + y = 2e^\theta \cos \phi$ and $x - y = 2ie^\theta \sin \phi$ Show that $\frac{\partial^2 u}{\partial \theta^2} + \frac{\partial^2 u}{\partial \phi^2} = 4xy \frac{\partial^2 u}{\partial x \partial y}$ (8)

Ans.

It is given that

$$x + y = 2e^\theta \cos \phi, x - y = 2ie^\theta \sin \phi$$

Adding $x = e^{\theta+i\phi}$, subtracting $y = e^{\theta-i\phi}$

$$\frac{\partial u}{\partial \theta} = \frac{\partial u}{\partial x} \cdot \frac{\partial x}{\partial \theta} + \frac{\partial u}{\partial y} \cdot \frac{\partial y}{\partial \theta} = e^{\theta+i\phi} \frac{\partial u}{\partial x} + e^{\theta-i\phi} \frac{\partial u}{\partial y}$$

$$\frac{\partial u}{\partial \theta} = x \frac{\partial u}{\partial x} + y \frac{\partial u}{\partial y} = \frac{\partial}{\partial \theta} = x \frac{\partial}{\partial x} + y \frac{\partial}{\partial y}$$

$$\frac{\partial u}{\partial \phi} = \frac{\partial u}{\partial x} \frac{\partial x}{\partial \phi} + \frac{\partial u}{\partial y} \frac{\partial y}{\partial \phi} = ie^{\theta+i\phi} \frac{\partial u}{\partial x} - ie^{\theta-i\phi} \frac{\partial u}{\partial y}$$

$$= i \left(x \frac{\partial}{\partial x} - y \frac{\partial}{\partial y} \right)$$

$$\therefore \frac{\partial^2 u}{\partial \theta^2} + \frac{\partial^2 u}{\partial \phi^2} = \left(x \frac{\partial}{\partial x} + y \frac{\partial}{\partial y} \right) \left(x \frac{\partial u}{\partial x} + y \frac{\partial u}{\partial y} \right) + i \left(x \frac{\partial}{\partial x} - y \frac{\partial}{\partial y} \right) i \left(x \frac{\partial u}{\partial x} - y \frac{\partial u}{\partial y} \right)$$

$$= x^2 \frac{\partial^2 u}{\partial x^2} + 2xy \frac{\partial^2 u}{\partial x \partial y} + y^2 \frac{\partial^2 u}{\partial y^2} + x \frac{\partial u}{\partial x} + y \frac{\partial u}{\partial y} - \left[x^2 \frac{\partial^2 u}{\partial x^2} - 2xy \frac{\partial^2 u}{\partial x \partial y} + y^2 \frac{\partial^2 u}{\partial y^2} + x \frac{\partial u}{\partial x} + y \frac{\partial u}{\partial y} \right]$$

$$\therefore \frac{\partial^2 u}{\partial \theta^2} + \frac{\partial^2 u}{\partial \phi^2} = 4xy \frac{\partial^2 u}{\partial x \partial y}$$

Alternative operate $\frac{\partial}{\partial y}$ operator on $\frac{\partial u}{\partial x}$

Q.151 Using the method of variation of parameter method, find the general solution of differential equation $y'' + 16y = 32 \sec 2x$ (8)

Ans.

The characteristic equation of the corresponding homogeneous equation is $m^2 + 16 = 0$. The complementary function is given by $y = A \cos 4x + B \sin 4x$ where $y_1 = \cos 4x$ and

$y_2 = \sin 4x$ are two linearly independent solutions of the homogeneous equation. The Wronskian is given by

$$W(x) = \begin{vmatrix} y_1 & y_2 \\ y_1' & y_2' \end{vmatrix} = 4. \quad A(x) = -\int \frac{32 \sec 2x \sin 4x}{4} dx = 8 \cos 2x + c_1$$

$$B(x) = \int \frac{32 \sec 2x \cos 4x}{4} dx = 8 \sin 2x - 4 \ln |\sec 2x + \tan 2x| + c_2$$

(P.I = $A(x)\cos 4x + B(x)\sin 4x$; where $A(x)$ and $B(x)$ are given by $A(x)$ as above.

Also $\sin 4x = 2 \sin x \cos x$ and $\cos 4x = 2 \cos^2 2x - 1$)

$$y = c_1 \cos 4x + c_2 \sin 4x + 8 \cos 2x - 4 \sin 4x \ln |\sec 2x + \tan 2x|$$

Q.152 Find the general solution of the equation $y'' - 4y' + 13y = 18e^{2x} \sin 3x$. (8)

Ans.

The characteristic equation of the homogeneous equation is $m^2 - 4m + 13 = 0$. The roots of the equation are $m = 2 + 3i, 2 - 3i$. The complementary function is $y_c(x) = e^{2x}(A \cos 3x + B \sin 3x)$

$$y_p(x) = 18 \frac{1}{D^2 - 4D + 13} (e^{2x} \sin 3x) = 18e^{2x} \frac{1}{(D+2)^2 - 4(D+2) + 13} \sin 3x$$

$$= 18e^{2x} \frac{1}{D^2 + 9} \sin 3x \quad (\text{a case of failure})$$

$$= 18e^{2x} \cdot x \frac{1}{2D} \sin 3x = 18xe^{2x} \frac{1}{2} \left(\frac{-\cos 3x}{3} \right) = -3xe^{2x} \cos 3x.$$

Thus $y(x) = \text{C.F.} + \text{P.I.}$

$$y(x) = e^{2x}(A \cos 3x + B \sin 3x) - 3xe^{2x} \cos 3x.$$

Q.153 Find the general solution of the equation $x^3 \frac{d^3 y}{dx^3} + 5x^2 \frac{d^2 y}{dx^2} + 5x \frac{dy}{dx} + y = x^2 + \ln x$. (8)

Ans.

Put $x = e^t$ i.e. $t = \log x$, $x \frac{dy}{dx} = Dy$, $x^2 \frac{d^2 y}{dx^2} = D(D-1)y$. Thus the given equation becomes

$\{D(D-1)(D-2) + 5D(D-1) + 5D + 1\} y = e^{2t} + 1$ or $(D^3 + 2D^2 + 2D + 1)y = e^{2t} + 1$ which is a linear equation with constant coefficients. It's A.E. is

$$m^3 + 2m^2 + 2m + 1 = 0 \Rightarrow m = -1, \frac{-1 \pm i\sqrt{3}}{2}$$

Thus C.F. = $(c_1 \cos(\sqrt{3}/2)t + c_2 \sin(\sqrt{3}/2)t)e^{-t/2} + c_3 e^{-t}$, and

$$\text{P.I.} = \frac{1}{D^3 + 2D^2 + 2D + 1} (e^{2t} + 1) = \frac{1}{21} e^{2t} + t - 2$$

$$\text{Thus } y = (c_1 \cos(\sqrt{3}/2)t + c_2 \sin(\sqrt{3}/2)t)e^{-t/2} + c_3 e^{-t} + \frac{1}{21} e^{2t} + t - 2$$

$$\text{Thus } y = \frac{1}{\sqrt{x}} (c_1 \cos(\sqrt{3}/2) \ln x + c_2 \sin(\sqrt{3}/2) \ln x) + \frac{c_3}{x} + \frac{1}{21} x^2 + \ln x - 2$$

Q.154 Solve $(1 + y^2)dx = (\tan^{-1} y - x)dy$ (8)

Ans.

The equation can be written as $\frac{dx}{dy} + \frac{x}{(1 + y^2)} = \frac{\tan^{-1} y}{(1 + y^2)}$ which is linear equation

$$I.F. = e^{\int \frac{1}{1+y^2} dy} = e^{\tan^{-1} y}. \text{ Thus } xe^{\tan^{-1} y} = \int \frac{\tan^{-1} y}{1 + y^2} e^{\tan^{-1} y} dy + c, \quad x = \tan^{-1} y - 1 + ce^{\tan^{-1} y}$$

Q.155 The set of vectors $\{x_1, x_2\}$, where $x_1 = (1, 3)^T$, $x_2 = (4, 6)^T$ is a basis in R^2 . Find a linear transformations T such that $Tx_1 = (-2, 2, -7)^T$ and $Tx_2 = (-2, -4, -10)^T$ (8)

Ans.

$$\text{Let the matrix } A = \begin{pmatrix} a_1 & b_1 \\ a_2 & b_2 \\ a_3 & b_3 \end{pmatrix}, \begin{pmatrix} a_1 & b_1 \\ a_2 & b_2 \\ a_3 & b_3 \end{pmatrix} \begin{bmatrix} 1 \\ 3 \end{bmatrix} = \begin{bmatrix} -2 \\ 2 \\ -7 \end{bmatrix}, \begin{pmatrix} a_1 & b_1 \\ a_2 & b_2 \\ a_3 & b_3 \end{pmatrix} \begin{bmatrix} 4 \\ 6 \end{bmatrix} = \begin{bmatrix} -2 \\ -4 \\ -10 \end{bmatrix}.$$

$$\begin{aligned} a_1 + 3b_1 &= -2; & 4a_1 + 6b_1 &= -2 \\ a_2 + 3b_2 &= 2; & 4a_2 + 6b_2 &= -4 \\ a_3 + 3b_3 &= -7; & 4a_3 + 6b_3 &= -10 \end{aligned}$$

Solving the above system of equations we get

$$a_1 = 1, b_1 = -1, a_2 = 4, b_2 = 2, a_3 = 2, b_3 = -3$$

Thus

$$A = \begin{pmatrix} 1 & -1 \\ -4 & 2 \\ 2 & -3 \end{pmatrix}$$

Q.156 Show that the matrix A is diagonalizable. $A = \begin{pmatrix} 3 & 1 & -1 \\ -2 & 1 & 2 \\ 0 & 1 & 2 \end{pmatrix}$. If, so, obtain the matrix P such

that $P^{-1}AP$ is a diagonal matrix. (8)

Ans.

The characteristic equation of the matrix A is given by

$$|A - \lambda I| = \begin{vmatrix} 3 - \lambda & 1 & -1 \\ -2 & 1 - \lambda & 2 \\ 0 & 1 & 2 - \lambda \end{vmatrix} = 0 \text{ or } \lambda^3 - 6\lambda^2 + 11\lambda - 6 = 0 \text{ or } \lambda = 1, 2, 3.$$

Eigenvector corresponding to $\lambda = 1$ is the solution of the system

$$(A - I)X = \begin{bmatrix} 2 & 1 & -1 \\ -2 & 0 & 2 \\ 0 & 1 & 1 \end{bmatrix} \begin{bmatrix} x \\ y \\ z \end{bmatrix} = \begin{bmatrix} 0 \\ 0 \\ 0 \end{bmatrix}. \text{ The solution of this system is } [1, -1, 1]^T.$$

Eigenvector corresponding to $\lambda = 2, 3$ are $[1, 0, 1]^T$ and $[0, 1, 1]^T$ Thus the matrix P is

given by $P = \begin{pmatrix} 1 & 1 & 0 \\ -1 & 0 & 1 \\ 1 & 1 & 1 \end{pmatrix}$ and $P^{-1}AP = \text{diag}(1, 2, 3)$.

Q.157 Investigate the values of λ for which the equations

$$(\lambda - 1)x + (3\lambda + 1)y + 2\lambda z = 0, (\lambda - 1)x + (4\lambda - 2)y + (\lambda + 3)z = 0,$$

$$2x + (3\lambda + 1)y + 3(\lambda - 1)z = 0$$

are consistent, hence find the ratios of $x:y:z$ when λ has the smallest of these value. **(8)**

Ans.

The system will be consistent if $\begin{vmatrix} \lambda - 1 & 3\lambda + 1 & 2\lambda \\ \lambda - 1 & 4\lambda - 2 & \lambda + 3 \\ 2 & 3\lambda + 1 & 3(\lambda - 1) \end{vmatrix} = 0$ or $\lambda = 0, 3$ Thus if $\lambda = 0, x = y = z$;

For $\lambda = 3$, system reduces to a single equation $2x + 10y + 6z = 0$.

Q.158 Find the first five non-vanishing terms in the power series solution of the initial value problem

$$(1 - x^2)y'' + 2xy' + y = 0, y(0) = 1, y'(0) = 1.$$

(11)

Ans.

The power series can be written as $y(x) = \sum_{m=0}^{\infty} c_m(x)^m$. Substituting in the given equation,

$$\sum_{m=2}^{\infty} m(m-1)c_m(x)^{m-2} - \sum_{m=2}^{\infty} m(m-1)c_m(x)^m + 2\sum_{m=1}^{\infty} mc_m(x)^m + \sum_{m=0}^{\infty} c_m(x)^m = 0$$

$$2c_2 + c_0 + 3(2c_3 + c_1)x + \sum_{m=2}^{\infty} [(m+2)(m+1)c_{m+2} - (m^2 - 3m - 1)c_m](x)^m = 0.$$

Setting the coefficients of successive powers of x to zero where c_0, c_1 are arbitrary constants.

We obtain $c_2 = -\frac{1}{2}(c_0), c_3 = -\frac{1}{2}(c_1), \dots$ The power series solution is

$$y(x) = c_0 \left[1 - \frac{1}{2}(x)^2 + \frac{1}{8}(x)^4 - \dots \right] + c_1 \left[(x) - \frac{1}{2}(x)^3 + \dots \right]$$

Q.159 Show that $\int xJ_0^2(x)dx = \frac{1}{2}x^2 [J_0^2(x) + J_1^2(x)]$ **(5)**

Ans.

Integrating by parts, we get

$$\int xJ_0^2 dx = \frac{x^2}{2} J_0^2 - \int \frac{x^2}{2} 2J_0 J_0' dx = \frac{x^2}{2} J_0^2 + \int xJ_1 \frac{d}{dx} (xJ_1) dx \quad (\text{as } J_0' = -J_1)$$

$$\int xJ_0^2(x) dx = \frac{1}{2} x^2 [J_0^2(x) + J_1^2(x)]$$

Q.160 Show that $J_{5/2}(x) = \sqrt{\frac{2}{n\pi}} \left[\frac{1}{x^2} (3-x^2) \sin x - \frac{3}{x} \cos x \right]$ (8)

Ans.

We know $J_{n+1}(x) = \frac{2n}{x} J_n(x) - J_{n-1}(x)$ Putting $n=1/2, 3/2,$ successively, we get

$$J_{3/2}(x) = \frac{1}{x} J_{1/2}(x) - J_{-1/2}(x), \quad J_{5/2}(x) = \frac{3}{x} J_{3/2}(x) - J_{1/2}(x)$$

$$J_{1/2}(x) = \sqrt{\frac{2}{n\pi}} \sin x \quad \text{and} \quad J_{-1/2}(x) = \sqrt{\frac{2}{n\pi}} \cos x \quad \text{Substituting the values, we get}$$

$$J_{5/2}(x) = \sqrt{\frac{2}{n\pi}} \left[\frac{1}{x^2} (3-x^2) \sin x - \frac{3}{x} \cos x \right]$$

Q.161 Show that $J_0^2 + 2J_1^2 + 2J_2^2 + \dots = 1$ (8)

Ans.

We have to use that $J_0^2 + 2J_1^2 + 2J_2^2 + \dots = 1$ ----- (1)

We know that Bessel functions $J_n(x), n \neq 0, 1, 2, \dots$ of various orders can be derived as

coefficients of various powers of t in the expansion of the function $e^{\frac{x}{2}(t-\frac{1}{t})}$; that is

$$e^{\frac{x}{2}(t-\frac{1}{t})} = \sum_{n=-\infty}^{\infty} t^n J_n(x) \quad (J_{-n}(x) = (-1)^n J_n(x))$$

$$= J_0(x) + \left(t - \frac{1}{t}\right) J_1(x) + \left(t^2 + \frac{1}{t^2}\right) J_2(x) + \dots \quad \text{----- (2)}$$

Put $t = \cos \theta + i \sin \theta, \frac{1}{t} = \cos \theta - i \sin \theta + \dots - \left(t^n + \frac{(-1)^n}{t^n}\right) J_n(x) + \dots$

Thus, $\left(t + \frac{1}{t}\right) = 2 \cos \theta, \left(t^2 + \frac{1}{t^2}\right) = 2 \cos 2\theta, \left(t - \frac{1}{t}\right) = 2i \sin \theta$

$$t^n + \frac{(-1)^n}{t^n} = \begin{cases} 2 \cos n\theta & \text{for } n \text{ an even integer} \\ 2i \sin n\theta & \text{for } n \text{ an odd integer} \end{cases} \quad \text{----- (3)}$$

Using the value of $t - \frac{1}{t}$ in (2), we get

$$e^{ix \sin \theta} = \cos x \sin \theta + i \sin(x \sin \theta) = J_0(x) + 2i \sin \theta J_1(x) + 2 \cos 2\theta J_2(x) + \dots + \dots$$

Equating real and imaginary parts in the generating function of Bessel's equation,
 $\cos(x \sin \theta) = J_0 + 2[J_2 \cos 2\theta + J_4 \cos 4\theta + \dots]$

$$\sin(x \sin \theta) = 2[J_1 \sin \theta + J_3 \sin 3\theta + \dots]$$

Squaring and integrating w.r.t. θ from 0 to π and noting that

$$\int_0^\pi \cos m\theta \cos n\theta d\theta = \int_0^\pi \sin m\theta \sin n\theta d\theta = 0, \int_0^\pi \cos^2 m\theta d\theta = \int_0^\pi \sin^2 m\theta d\theta = \frac{\pi}{2}. \text{ Thus}$$

$$[J_0(x)]^2 \pi + 2[J_2(x)]^2 \pi + 2[J_4(x)]^2 \pi + \dots = \int_0^\pi \cos^2(x \sin \theta) d\theta$$

$$2[J_1(x)]^2 \pi + 2[J_3(x)]^2 \pi + 2[J_5(x)]^2 \pi + \dots = \int_0^\pi \sin^2(x \sin \theta) d\theta$$

Adding, we get $[J_0(x)]^2 + 2[J_1(x)]^2 + 2[J_2(x)]^2 + \dots = \frac{1}{\pi} \int_0^\pi d\theta = 1$

Q.162 Compute $f_{xy}(0,0)$, $f_{yx}(0,0)$ for the function

$$f(x, y) = \begin{cases} \frac{xy^3}{x+y^2}, & (x, y) \neq (0, 0) \\ 0, & (x, y) = (0, 0) \end{cases}$$

Also discuss the continuity of f_{xy} , f_{yx} at $(0,0)$.

(8)

Ans.

For obtaining $f_{xy}(0,0)$ and $f_{yx}(0,0)$ we need the partial derivatives $f_x(0,0)$ and $f_y(0,0)$.

For obtaining these derivatives we use the definition of f_x and f_y :

$$f_x = \lim_{\Delta x \rightarrow 0} \frac{f(x + \Delta x, y) - f(x, y)}{\Delta x}; \quad f_y = \lim_{\Delta y \rightarrow 0} \frac{f(x, y + \Delta y) - f(x, y)}{\Delta y}.$$

$$f_x(0,0) = \lim_{\Delta x \rightarrow 0} \frac{f(\Delta x, 0) - f(0,0)}{\Delta x} = 0, \quad f_y(0,0) = \lim_{\Delta y \rightarrow 0} \frac{f(0, \Delta y) - f(0,0)}{\Delta y} = 0,$$

$$f_x(0, y) = \lim_{\Delta x \rightarrow 0} \frac{f(\Delta x, y) - f(0, y)}{\Delta x} = \lim_{\Delta x \rightarrow 0} \frac{y^3 \Delta x}{[\Delta x + y^2] \Delta x} = y$$

$$f_y(x, 0) = \lim_{\Delta y \rightarrow 0} \frac{f(x, \Delta y) - f(x, 0)}{\Delta y} = \lim_{\Delta y \rightarrow 0} \frac{x(\Delta y)^3}{[x + (\Delta y)^2] \Delta y} = 0.$$

$$f_{xy}(0,0) = \lim_{\Delta x \rightarrow 0} \frac{f_y(\Delta x, 0) - f_y(0,0)}{\Delta x} = 0,$$

$$f_{yx}(0,0) = \lim_{\Delta y \rightarrow 0} \frac{f_x(0, \Delta y) - f_x(0,0)}{\Delta y} = \lim_{\Delta y \rightarrow 0} \frac{\Delta y}{\Delta y} = 1. \text{ Hence } f_{xy}(0,0) \neq f_{yx}(0,0).$$

Thus f_{xy}, f_{yx} are not continuous at $(0,0)$.

Q.163 Find the minimum values of $x^2 + y^2 + z^2$ subject to the condition $xyz = a^3$ (8)

Ans.

Let $F = x^2 + y^2 + z^2 + \lambda(xyz - a^3)$. The necessary conditions for extremum is $\frac{\partial F}{\partial x} = 2x + \lambda yz = 0, \frac{\partial F}{\partial y} = 2y + \lambda xz = 0, \frac{\partial F}{\partial z} = 2z + \lambda xy = 0$, thus we get $\lambda xyz = -2x^2 = -2y^2 = -2z^2. \therefore x^2 = y^2 = z^2$. At each of these points, the value of the given function is $x^2 + y^2 + z^2 = 3a^2$. Arithmetic Mean of x^2, y^2, z^2 is $AM = \frac{(x^2 + y^2 + z^2)}{3}$, the Geometric Mean of x^2, y^2, z^2 is $GM = (x^2 y^2 z^2)^{1/3} = a^2$. Since $AM \geq GM$, we get $x^2 + y^2 + z^2 \geq 3a^2$. Hence, all the above points are the points of constrained minimum and the minimum value of $x^2 + y^2 + z^2$ is $3a^2$.

Q.164 The function $f(x, y) = x^2 - xy + y^2$ is approximated by a first degree Taylor's polynomial about the point $(2,3)$. Find a square $|x-2| < \delta, |y-3| < \delta$ with centre at $(2,3)$ such that the error of approximation is less than or equal to 0.1 in magnitude for all points within the square. (8)

Ans.

We have $f_x = 2x - y, f_y = 2y - x, f_{xx} = 2, f_{xy} = -1, f_{yy} = 2$.

The maximum absolute error in the first degree approximation is given by $|R_1| \leq \frac{B}{2} [|x-2| + |y-3|]^2$, where $B = \max[|f_{xx}|, |f_{xy}|, |f_{yy}|] = 2$. Also it is given that $|x-2| < \delta, |y-3| < \delta$, therefore we want to determine the value of δ such that $|R_1| \leq \frac{2}{2} [\delta + \delta]^2 < 0.1, \text{ or } 4\delta^2 < 0.1 \text{ or } \delta = 0.1581$.

Q.165 Find the Volume of the ellipsoid $\frac{x^2}{a^2} + \frac{y^2}{b^2} + \frac{z^2}{c^2} = 1$ (8)

Ans.

Volume = 8(volume in the first octant). The projection of the surface $z = c\sqrt{1 - \frac{x^2}{a^2} - \frac{y^2}{b^2}}$ in the x-y plane is the region in the first quadrant of the ellipse $\frac{x^2}{a^2} + \frac{y^2}{b^2} = 1$.

Thus

$$V = 8 \int_0^a \int_0^{\sqrt{1-x^2/c^2}} \sqrt{1 - \frac{x^2}{a^2} - \frac{y^2}{b^2}} dy dx$$

Using the transformation $x = aX, y = bY, z = cZ$, the desired volume can be expressed as

$$8abc \int_0^a \int_0^{\sqrt{1-x^2/a^2}} \int_0^{\sqrt{1-x^2/a^2-y^2/b^2}} dXdYdZ \text{ where } X^2 + Y^2 + Z^2 = 1 \text{ which is a sphere of radius 1.}$$

Using spherical polar coordinates $X = r \sin \theta \cos \phi, Y = r \sin \theta \sin \phi, Z = r \cos \theta$.

$$V = abc \int_0^1 \int_0^\pi \int_0^{2\pi} r^2 \sin \theta dr d\theta d\phi = \int_0^1 r^2 dr \int_0^\pi \sin \theta d\theta \int_0^{2\pi} d\phi = \frac{1}{3} 2 \cdot 2\pi abc.$$

Q.166 Solve the differential equation $(3x^2y^3e^y + y^3 + y^2)dx + (x^3y^3e^y - xy)dy = 0$ (8)

Ans.

Here $M = 3x^2y^3e^y + y^3 + y^2; N = x^3y^3e^y - xy$

For the given equation to be exact $\frac{\partial M}{\partial y} = \frac{\partial N}{\partial x}$. Consequently, we determine

$$\frac{\partial M}{\partial y} = 9x^2y^2e^y + 3x^2y^3e^y + 3y^2 + 2y, \quad \frac{\partial N}{\partial x} = 3x^2y^3e^y - y.$$

As $\frac{\partial M}{\partial y} \neq \frac{\partial N}{\partial x}$, equation is not exact. Accordingly, we determine the I.F. by examining

$$\frac{1}{M} \left[\frac{\partial M}{\partial y} - \frac{\partial N}{\partial x} \right] = \frac{3(3x^2y^2e^y + y^2 + y)}{y(3x^2y^2e^y + y^2 + y)} = \frac{3}{y}$$

$$\therefore \text{the I.F.} = e^{-\int \frac{3}{y} dy} = e^{-3 \log y} = \frac{1}{y^3}.$$

On multiplying throughout by $\frac{1}{y^3}$ and integrating (using the rule of exact) d.e. we get

$$y(x^3e^y + x) + x = ky, \text{ where } k \text{ is constant integration.}$$

Q.167 Using the method of variation of parameters, solve the differential equation $y'' + 3y' + 2y = 2e^x$. (8)

Ans.

Auxiliary equation is $m^2 + 3m + 2 = 0 = (m+1)(m+2) = 0, m = -1, -2$

\therefore the C.F. = $C_1e^{-x} + C_2e^{-2x}$. Its P.I. is given by $A(x)e^{-x} + B(x)e^{-2x}$

Using the method of variation of parameters A(x) and B(x) are given by

$$A(x) = -\int \frac{r(x)e^{-2x}}{W(x)} dx + C_3, \quad B(x) = -\int \frac{r(x)e^{-x}}{W(x)} dx + C_4$$

Where r(x) denotes the RHS of the given differential equation i.e. $r(x) = 2e^x$ and W(x) is the Wronskian

$$W(x) = \begin{vmatrix} e^{-x} & e^{-2x} \\ -e^{-x} & -2e^{-2x} \end{vmatrix} = -e^{-3x}.$$

Thus, $A(x) = -\int \frac{2e^x e^{-2x}}{-e^{-3x}} dx = +2 \int e^{2x} dx = e^{2x} + C_3$

$$B(x) = \int \frac{2e^x e^{-x}}{-e^{-3x}} dx = -\frac{2}{3} e^{3x} + C_4$$

and the general solution is C.F. + P.I.

$$y = C_1 e^{-x} + C_2 e^{-2x} + e^{-x} \{e^{2x} + C_3\} + e^{-2x} \left\{ -\frac{2}{3} e^{3x} + C_4 \right\} = C_5 e^{-x} + C_6 e^{-2x} + e^x + \frac{2}{3} e^{3x}.$$

Q.168 Find the general solution of the equation $y'' + 4y' + 3y = x \sin 2x$. (8)

Ans.

The characteristic equation of the homogeneous equation is $m^2 + 4m + 3 = 0$. The roots of the equation are $m = -1, -3$. The complementary function is $y_c(x) = Ae^{-x} + Be^{-3x}$.

$$\begin{aligned} \text{P.I.} &= \frac{1}{D^2 + 4D + 3} \text{Im } x e^{2ix} = \text{Im } e^{2ix} \left[(D + 2i)^2 + 4(D + 2i) + 3 \right]^{-1} x \\ &= \text{Im } \frac{e^{2ix}}{8i - 1} \left[1 - \frac{4(1+i)D}{8i - 1} + \dots \right]^{-1} x = \text{Im } \left\{ \frac{e^{2ix}}{8i - 1} \left[x - \frac{4(1+i)}{8i - 1} \right] \right\} \\ &= -\frac{1}{4225} [65x(8 \cos 2x + \sin 2x) - 188 \cos 2x - 316 \sin 2x] \end{aligned}$$

Thus $y = Ae^{-x} + Be^{-3x} - \frac{1}{4225} [65x(8 \cos 2x + \sin 2x) - 188 \cos 2x - 316 \sin 2x]$

$$\frac{1}{F(D)} x \varphi(x) = \left[\left(x - \frac{F'(D)}{F(D)} \right) \frac{1}{F(D)} \varphi(x) \right]$$

Here $F(D) = D^2 + 4D + 3 \rightarrow F'(D) = 2D + 4; \varphi(x) = \sin 2x$

$$\frac{1}{D^2 + 4D + 3} \sin 2x = \frac{1}{-4 + 4D + 3} \sin 2x = \frac{4D + 1}{16D^2 - 1} \sin 2x = \sin 2x = \frac{8 \cos 2x + \sin 2x}{-65}$$

Thus the first term of the P.I. = $\frac{-x}{65} (8 \cos 2x + \sin 2x)$

Similarly, $\frac{-2D + 4}{D^2 - 4D + 3} \left\{ -\frac{1}{65} (8 \cos 2x + \sin 2x) \right\} = -\frac{8}{65} \frac{(2D + 4)}{(D^2 + 4D + 3)} \cos 2x$

$$-\frac{1}{65} \frac{2D + 4}{(D^2 + 4D + 3)} \sin 2x; = A + B$$

$$A = -\frac{8}{65} \cdot \frac{(2D + 4)}{4D - 1} \cos 2x = -\frac{8}{65} \cdot \frac{(2D + 4)(4D + 1)}{16D^2 - 1} \cos 2x = \frac{8}{(65)^2} \{8D^2 + 8D + 4\} \cos 2x$$

$$= \frac{8}{(65)^2} \{8(-4) \sin 2x - 36 \sin 2x + 4 \cos 2x\}$$

$$\begin{aligned}
 B &= -\frac{1}{65} \frac{(2D+4)(4D+1)}{16D^2-1} \sin 2x = -\frac{1}{65} \left\{ \frac{8D^2+18D+4}{(-65)} \right\} \sin 2x \\
 &= +\frac{1}{(65)^2} \{-32 \cos 2x - 36 \sin 2x + 4 \cos 2x\}.
 \end{aligned}$$

Q.169 The eigenvectors of a 3 x 3 matrix A corresponding to the eigen values 1, 1, 3 are $[1, 0, -1]^T$, $[0, 1, -1]^T$, $[1, 1, 0]^T$. Find the matrix A. (8)

Ans.

From the eigen values 1,1,3 we write the Diagonal matrix D as

$$D = \begin{bmatrix} 1 & 0 & 0 \\ 0 & 1 & 0 \\ 0 & 0 & 3 \end{bmatrix}; \text{ From the eigen vectors we write the Modal matrix}$$

$$P = \begin{bmatrix} 1 & 0 & 1 \\ 0 & 1 & 1 \\ -1 & -1 & 0 \end{bmatrix}; \text{ For obtaining the matrix } A = PDP^{-1}, \text{ we proceed as follows}$$

$$P^{-1} = \frac{\text{Adjoint } P}{|P|} = \frac{\text{Transpose of Cofactor elements matrix}}{|P|}$$

$$P^{-1} = \frac{1}{2} \begin{bmatrix} 1 & -1 & -1 \\ -1 & 1 & 1 \\ 1 & 1 & 1 \end{bmatrix} \text{ where } |P| = 2$$

$$DP^{-1} = \frac{1}{2} \begin{bmatrix} 1 & 0 & 0 \\ 0 & 1 & 0 \\ 0 & 0 & 3 \end{bmatrix} \begin{bmatrix} 1 & -1 & -1 \\ -1 & 1 & 1 \\ 1 & 1 & 1 \end{bmatrix} = \frac{1}{2} \begin{bmatrix} 1 & -1 & -1 \\ -1 & 1 & -1 \\ 3 & 3 & 3 \end{bmatrix}$$

Thus

$$\begin{aligned}
 A = PDP^{-1} &= \frac{1}{2} \begin{bmatrix} 1 & 0 & 1 \\ 0 & 1 & 1 \\ -1 & -1 & 0 \end{bmatrix} \begin{bmatrix} 1 & -1 & -1 \\ -1 & 1 & -1 \\ 3 & 3 & 3 \end{bmatrix} = \frac{1}{2} \begin{bmatrix} 4 & 2 & 2 \\ 2 & 4 & 2 \\ 0 & 0 & 2 \end{bmatrix} \\
 &= \begin{bmatrix} 2 & 1 & 1 \\ 1 & 2 & 1 \\ 0 & 0 & 1 \end{bmatrix}
 \end{aligned}$$

Q.170 Test for consistency and solve the system of equations (8)
 $5x + 3y + 7z = 4, 3x + 26y + 2z = 9, 7x + 2y + 10z = 5$

Ans.

The given system of equations can be expressed as

$$\begin{bmatrix} 5 & 3 & 7 \\ 3 & 26 & 2 \\ 7 & 2 & 10 \end{bmatrix} \begin{bmatrix} x \\ y \\ z \end{bmatrix} = \begin{bmatrix} 4 \\ 9 \\ 5 \end{bmatrix} \text{ or } AX = B$$

Using row transformations A can be expressed as

$$\begin{bmatrix} 5 & 3 & 7 \\ 0 & 11 & -1 \\ 0 & 0 & 0 \end{bmatrix} \begin{bmatrix} x \\ y \\ z \end{bmatrix} = \begin{bmatrix} 4 \\ 3 \\ 0 \end{bmatrix}$$

Which is of rank 2. The augmented matrix

$$\begin{bmatrix} 5 & 3 & 7 & 4 \\ 0 & 11 & -1 & 3 \\ 0 & 0 & 0 & 0 \end{bmatrix}$$

is used of rank. Consequently, system is consistent. On solving we get

$$x = \frac{7}{11} - \frac{16}{11}z, y = \frac{3}{11} + \frac{1}{11}z. \text{ where } z \text{ is a parameter. Thus } x = \frac{7}{11}, y = \frac{3}{11}, z = 0.$$

Q.171 Given that $A = \begin{bmatrix} 0 & 1+2i \\ -1+2i & 0 \end{bmatrix}$ show that $(I - A)(I + A)^{-1}$ is a unitary matrix. (8)

Ans.

$$I + A = \begin{bmatrix} 1 & 0 \\ 0 & 1 \end{bmatrix} + \begin{bmatrix} 0 & 1+2i \\ -1+2i & 0 \end{bmatrix} = \begin{bmatrix} 1 & 1+2i \\ -1+2i & 1 \end{bmatrix};$$

$$\begin{bmatrix} 1 & 1+2i \\ -1+2i & 1 \end{bmatrix} = 1 - (4i^2 - 1) = 6.$$

$$(I + A)^{-1} = \frac{Adj(I + A)}{|I + A|} = \frac{Transpose\ of\ Cofactor\ elements\ matrix}{\det(I + A)}$$

$$= \frac{1}{6} \begin{bmatrix} 1 & -1-2i \\ 1-2i & 1 \end{bmatrix}$$

$$[I - A] = \begin{bmatrix} 1 & 0 \\ 0 & 1 \end{bmatrix} - \begin{bmatrix} 0 & 1+2i \\ -1+2i & 0 \end{bmatrix} = \begin{bmatrix} 1 & -1-2i \\ 1-2i & 1 \end{bmatrix}$$

$$[I - A][I + A]^{-1} = \begin{bmatrix} 1 & -1-2i \\ 1-2i & 1 \end{bmatrix} \frac{1}{6} \begin{bmatrix} 1 & -1-2i \\ 1-2i & 1 \end{bmatrix} = \frac{1}{6} \begin{bmatrix} -4 & -2-4i \\ 2-4i & -4 \end{bmatrix} \text{ ----- (1)}$$

For proving that $[I - A][I + A]^{-1}$ is a unitary matrix we need the transpose of the above matrix. Consequently

$$\frac{1}{6} \begin{bmatrix} -4 & -2-4i \\ 2-4i & -4 \end{bmatrix} = \frac{1}{6} \begin{bmatrix} -4 & 2+4i \\ -2+4i & -4 \end{bmatrix} \text{ ----- (2)}$$

The product of (1) and (2) is a unitary matrix. $I = \begin{pmatrix} 1 & 0 \\ 0 & 1 \end{pmatrix}$.

Q.172 Show that the transformation

$y_1 = x_1 - x_2 + x_3, y_2 = 3x_1 - x_2 + 2x_3, y_3 = 2x_1 - 2x_2 + 3x_3$ is non-singular. Find the inverse transformation. (8)

Ans.

Writing the given transformation in matrix form $Y = AX$.

$$\begin{bmatrix} y_1 \\ y_2 \\ y_3 \end{bmatrix} = \begin{bmatrix} 1 & -1 & 1 \\ 3 & -1 & 2 \\ 2 & -2 & 3 \end{bmatrix} \begin{bmatrix} x_1 \\ x_2 \\ x_3 \end{bmatrix} \because |A| = 2. \text{ Therefore the given matrix A is non-singular and hence the}$$

given transformation is also regular. Thus, $X = A^{-1}Y$.

$$\begin{bmatrix} x_1 \\ x_2 \\ x_3 \end{bmatrix} = \frac{1}{2} \begin{bmatrix} 1 & 1 & -1 \\ -5 & 1 & 1 \\ -4 & 0 & 2 \end{bmatrix} \begin{bmatrix} y_1 \\ y_2 \\ y_3 \end{bmatrix}.$$

Hence we arrive at the following expressions for the inverse transformation

$$x_1 = \frac{1}{2}(y_1 + y_2 - y_3),$$

$$x_2 = \frac{1}{2}(-5y_1 + y_2 + y_3),$$

$$x_3 = (-4y_1 + 2y_3)$$

Q.173 If $u = f(x,y), x = r\cos\theta, y = r\sin\theta$, then show that $\left(\frac{\partial u}{\partial x}\right)^2 + \left(\frac{\partial u}{\partial y}\right)^2 = \left(\frac{\partial u}{\partial r}\right)^2 + \frac{1}{r^2}\left(\frac{\partial u}{\partial \theta}\right)^2$ (8)

Ans.

$$\begin{aligned} \frac{\partial u}{\partial x} &= \frac{\partial u}{\partial r} \frac{\partial r}{\partial x} + \frac{\partial u}{\partial \theta} \frac{\partial \theta}{\partial x} \\ \frac{\partial u}{\partial x} &= \cos\theta \frac{\partial u}{\partial r} - \frac{\sin\theta}{r} \frac{\partial u}{\partial \theta} \end{aligned} \quad \text{----- (1)}$$

Similarly,

$$\begin{aligned} \frac{\partial u}{\partial y} &= \frac{\partial u}{\partial r} \frac{\partial r}{\partial y} + \frac{\partial u}{\partial \theta} \frac{\partial \theta}{\partial y} \\ \frac{\partial u}{\partial y} &= \sin\theta \frac{\partial u}{\partial r} + \frac{\cos\theta}{r} \frac{\partial u}{\partial \theta} \end{aligned} \quad \text{----- (2)}$$

Squaring (1) and (2) and adding, we get

$$\begin{aligned} \left(\frac{\partial u}{\partial x}\right)^2 + \left(\frac{\partial u}{\partial y}\right)^2 &= \cos^2\theta \left(\frac{\partial u}{\partial r}\right)^2 + \frac{\sin^2\theta}{r^2} \left(\frac{\partial u}{\partial \theta}\right)^2 - \frac{2\sin\theta\cos\theta}{r} \frac{\partial u}{\partial r} \cdot \frac{\partial u}{\partial \theta} \\ &\quad + \sin^2\theta \left(\frac{\partial u}{\partial r}\right)^2 + \frac{\cos^2\theta}{r^2} \left(\frac{\partial u}{\partial \theta}\right)^2 + \frac{2\sin\theta\cos\theta}{r} \frac{\partial u}{\partial r} \cdot \frac{\partial u}{\partial \theta} \end{aligned}$$

$$= \left(\frac{\partial u}{\partial r}\right)^2 + \frac{1}{r^2} \left(\frac{\partial u}{\partial \theta}\right)^2$$

Q.174 Find the power series solution about the origin of the equation

$$x^2 y'' + 6xy' + (6 + x^2)y = 0. \tag{11}$$

Ans.

The point $x = 0$ is a regular singular point. The power series can be written as

$y(x) = \sum_{m=0}^{\infty} c_m(x)^{m+r}$. Substituting in the given equation, we get

$$\sum_{m=0}^{\infty} (m+r)(m+r-1)c_m(x)^{m+r} + 6 \sum_{m=0}^{\infty} (m+r+1)c_m(x)^{m+r} + \sum_{m=0}^{\infty} c_m(x)^{m+r+2} = 0$$

$$\sum_{m=0}^{\infty} [(m+r)(m+r+5)+6]c_m(x)^{m+r} + 6 \sum_{m=0}^{\infty} c_m(x)^{m+r+2} = 0$$

The indicial roots are $r = -2, -3$.

Setting the coefficients of x^{r+1} to zero, we get

$[(r+1)(r+6)+6]c_1 = 0$, For $r = -2$, $c_1 = 0$ and for $r = -3$, c_1 is arbitrary constants. Thus the

remaining terms are $\sum_{m=2}^{\infty} [(m+r)(m+r+5)+6]c_m(x)^{m+r} + 6 \sum_{m=0}^{\infty} c_m(x)^{m+r+2} = 0$ We obtain

$$\sum_{m=0}^{\infty} \{[(m+r+2)(m+r+7)+6]c_{m+2} + c_m\}(x)^{m+r+2} = 0. \text{ Thus}$$

$$c_{m+2} = \frac{c_m}{(m+r+2)(m+r+7)+6}, m \geq 0. \text{ For } r = -3, c_2 = -\frac{c_0}{2}, c_3 = -\frac{c_1}{6}, \dots$$

The power series solution for $r = -3$ is

$$y(x) = x^{-3} \left\{ c_0 \left[1 - \frac{x^2}{2!} + \frac{x^4}{4!} - \dots \right] + c_1 \left[x - \frac{x^3}{3!} + \frac{x^5}{5!} - \dots \right] \right\} = c_0 \left(\frac{\cos x}{x^3} \right) + c_1 \left(\frac{\sin x}{x^3} \right)$$

$$= c_0 y_1(x) + c_1 y_2(x)$$

For $r = -2$, we get $c_1 = 0, c_2 = -\frac{c_0}{6}, c_3 = 0$ The power series solution for $r = -2$

$$y^*(x) = x^{-2} c_0 \left[1 - \frac{x^2}{3!} + \frac{x^4}{5!} - \dots \right] = c_0 y_2(x).$$

Q.175 Find the value of $P_3(2.1)$. (5)

Ans.

There are two ways of obtaining the value of $P_3(2.1)$

- (i) Through recurrence relation
- (ii) Using Rodrigue's formula

Through (i) we make use of the following recurrence relation

$$(n+1)P_{n+1}(x) = (2n+1)xP_n(x) - nP_{n-1}(x) \tag{1}$$

With $P_0(x) = 1, P_1(x) = x$ ----- (2)

Putting $n = 1$; we get (Using equation 1)

$2P_2(x) = 3xP_1(x) - P_0(x)$ ----- (3)

For $n = 2$, equation (1) yields

$3P_3(x) = 5xP_2(x) - 2P_1(x) = \frac{5x}{2} \{3xP_1(x) - P_0(x)\} - 2P_1(x)$ ---- (4)

Thus

$$P_3(x) = \frac{1}{6} 5x \{3x^2 - 1\} - \frac{2}{3} x = \frac{5}{2} x^3 - x \left(\frac{5}{6} + \frac{2}{3} \right)$$

$$= \frac{5}{2} x^3 - \frac{3}{2} x; P_3(2.1) = \frac{1}{2} (5(2.1)^2 - 3)(2.1) \simeq 20.005$$

Method II : Using Rodrigue’s formula

$$P_n(x) = \frac{1}{2^n n!} \frac{d^n}{dx^n} (x^2 - 1)^n$$

$$P_0(x) = 1; P_1(x) = \frac{1}{2 \cdot 1!} \frac{d}{dx} (x^2 - 1) = \frac{1}{2} \cdot 2x = x$$

$$P_2(x) = \frac{1}{4 \cdot 2!} \frac{d^2}{dx^2} (x^2 - 1)^2 = \frac{1}{8} \frac{d}{dx} (2(x^2 - 1)2x) = \frac{1}{2} \frac{d}{dx} (x^3 - x) = \frac{1}{2} (3x^2 - 1)$$

$$P_3(x) = \frac{1}{8 \cdot 3!} \frac{d^3}{dx^3} (x^2 - 1)^3 = \frac{1}{2} (5x^3 - 3x)$$

Thus $P_3(2.1) = \frac{1}{2} \{5(2.1)^2 - 3\}(2.1) = \frac{1}{2} (40.005) = 20.0025$

Q.176 Prove the Orthogonal property of Legendre Polynomials. (8)

Ans.

The orthogonality property of the Legendre’s functions is defined by the relation

$$\int_{-1}^1 P_m(x) P_n(x) dx = \begin{cases} 0, & m \neq n \\ \frac{2}{n+1}, & m = n \end{cases}$$
 ----- (1)

We first prove (1) form the case $m \neq n$.

Let $u = P_m(x)$ and $v = P_n(x)$. Thus, u and v satisfy respectively the following differential equations:

$$(1-x)^2 \frac{d^2 u}{dx^2} - 2u \frac{du}{dx} + m(m+1)u = 0$$
 ----- (2)

$$(1-x)^2 \frac{d^2 v}{dx^2} - 2v \frac{dv}{dx} + n(n+1)v = 0$$
 ----- (3)

Multiplying equation (2) by v and equation (3) by u and subtracting, we get

$$(1-x^2) \left[v \frac{d^2 u}{dx^2} - u \frac{d^2 v}{dx^2} \right] - 2x \left[v \frac{du}{dx} - u \frac{dv}{dx} \right] + [m(m+1) - n(n+1)] uv = 0$$

Or $\frac{d}{dx} \left[(1-x^2) \left(v \frac{du}{dx} - u \frac{dv}{dx} \right) \right] + (m-n)(m-n+1)uv = 0$ ----- (4)

Integrating equation (4) w r to x between the limits (-1) to (1) we get

$\left[(1-x^2) \left(v \frac{du}{dx} - u \frac{dv}{dx} \right) \right]_{-1}^1 + (m-n)(m+n+1) \int_{-1}^1 uv dx = 0$ ----- (5)

Thus, for $m \neq n$

$\int_{-1}^1 P_m(x) P_n(x) dx = 0$

Case III; $m = n$; $\int_{-1}^1 P_n^2(x) dx = \frac{2}{2n+1}$

Above result can be proved either through Rodrigue’s formula

$P_n(x) = \frac{1}{2^n n!} \frac{d^n}{dx^n} (x^2 - 1)^n$ ----- (6)

Or using generating function of the Legendres polynomial, that is

$(1 - 2xt + t^2)^{-1/2} = \sum_{n=0}^{\infty} t^n P_n(x)$ ----- (7)

However, we use equation (7) to prove (1) for $m = n$.

Squaring (7) we get

$(1 - 2xt + t^2)^{-1} = \sum_{n=0}^{\infty} t^{2n} P_n^2(x) + \sum_{n=0}^{\infty} \sum_{m=0}^{\infty} t^{m+n} P_n(x) P_m(x)$ ----- (8)

Interpreting (8) w.r.to x between (-1) to (+1), we get

$\int_{-1}^1 \frac{dx}{1 - 2xt + t^2} = \sum_{n=0}^{\infty} t^{2n} \int_{-1}^1 P_n^2(x) dx + \sum_{n=0}^{\infty} \sum_{m=0}^{\infty} t^{m+n} \int_{-1}^1 P_m(x) P_n(x) dx$ ----- (9)

Using the orthogonality property for case $m \neq n$, we get

$\frac{1}{2t} \{ \log(1 - 2x + t^2) \} = \sum_{n=0}^{\infty} t^{2n} \int_{-1}^1 P_n^2(x) dx$

Or $\frac{1}{2t} \{ \log(1-t)^2 - \log(1+t)^2 \} = \text{R.H.S.}$

Or $\frac{1}{t} \{ \log(1-t) - \log(1+t) \} = \text{R.H.S.}$

Or $\frac{2}{t} \left\{ t + \frac{t^3}{3} + \frac{t^5}{5} + \dots \right\} = \text{R.H.S.}$

Or $2 \left\{ 1 + \frac{t^2}{3} + \frac{t^4}{5} + \dots + \frac{t^{2n}}{2^{n+1}} + \dots \right\} = \text{R.H.S.}$

Equating the coefficients of t^{2n} , we get

$\int_{-1}^1 P_n^2(x) dx = \frac{2}{2^{n+1}}$